



Agenzia Nazionale per le Nuove Tecnologie,
l'Energia e lo Sviluppo Economico Sostenibile



Ministero dello Sviluppo Economico

RICERCA DI SISTEMA ELETTRICO

SIET 01 619 RT10

Realizzazione del circuito prova barre

C. Congiu, M. Greco

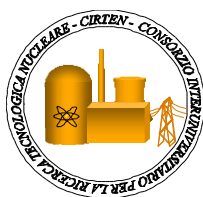

REALIZZAZIONE DEL CIRCUITO PROVA BARRE

C. Congiu, M. Greco

Settembre 2010

Report Ricerca di Sistema Elettrico

Accordo di Programma Ministero dello Sviluppo Economico – ENEA

Area: Produzione e fonti energetiche

Tema: Nuovo Nucleare da Fissione

Responsabile Tema: Stefano Monti, ENEA

Titolo

Realizzazione del circuito prova barre

Ente emittente: SIET

PAGINA DI GUARDIA**Descrittori**

Tipologia del documento: Rapporto tecnico/Technical Report

Collocazione contrattuale: Accordo di programma ENEA-MSE: tema di ricerca "Nuovo nucleare da fissione"

Argomenti trattati: Reattori ad acqua leggera/Light Water Reactors

Sommario

Questo rapporto è stato emesso nell'ambito del secondo PAR dell'accordo di programma ENEA-MSE e costituisce uno dei deliverable dell'obiettivo D "Prova Integrale IRIS – progettazione, realizzazione circuito di prova delle canne scaldanti" della linea progettuale LP2 "Reattori Evolutivi INTD - International Near Term Deployment" del tema di ricerca "Nuovo Nucleare da Fissione".

Il documento costituisce il dossier della documentazione finale dell'impianto sperimentale, denominato "Circuito Prova Barre". . In particolare esso descrive il processo di realizzazione dalla fase di progettazione esecutiva a quella di commissioning.

Note

Copia n.

In carico a:

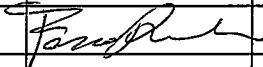
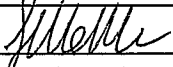
2			NOME			
			FIRMA			
1			NOME			
			FIRMA			
0	EMISSIONE	28/09/2010	NOME	F. Bianchi		S. Monti
			FIRMA			
REV.	DESCRIZIONE	DATA		CONVALIDA	VISTO	APPROVAZIONE

EMITTENTE

issued by
Unità di Produzione
Production Unit
Laboratorio Prova Grandi Impianti

CLIENTE: ENEA
client

COMMESSA: 1PN000DB90245
job

DISCO:
disk

PAGINA: 1 DI: 53
page of

IDENTIFICATIVO: 01619RT10
document

Classe Ris.:
confidentiality



Allegati:
enclosures

TITOLO: REALIZZAZIONE CIRCUITO PROVA BARRE
title

REDATTORI: C. Congiu, M. Greco
prepared by

LISTA DI DISTRIBUZIONE
distribution list

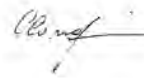
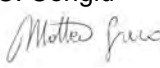
S. Gandolfi	S.I.E.T.
R. Maiocchi	S.I.E.T.
C. Congiu	S.I.E.T.
M. Greco	S.I.E.T.
A. Achilli	S.I.E.T.
G. Cattadori	S.I.E.T.
R. Ferri	S.I.E.T.
S. Botti	S.I.E.T.
G. Tortora	S.I.E.T.
G. Filella	S.I.E.T.
R. Tinti	ENEA
F. Bianchi	ENEA

0	17/09/2010	EMMISSIONE <i>issue</i>	 C. Congiu  M. Greco	 A. Achilli
0	05/08/2010	BOZZA <i>draft</i>	C. Congiu M. Greco	A. Achilli
REV <i>rev</i>	DATA <i>date</i>	DESCRIZIONE <i>description</i>	REDAZIONE <i>prepared by</i>	APPROVAZIONE <i>approved by</i>

Informazioni strettamente riservate di proprietà SIET SpA - Da non utilizzare per scopi diversi da quelli per cui sono state fornite.
Confidential information property of SIET SpA - Not to be used for any purpose other than those for which it is supplied.

Indice

1	INTRODUZIONE.....	6
2	CONTENUTI DEL DOCUMENTO.....	7
3	DETTAGLI CONTENUTO DOCUMENTI RICHIESTI.....	8
3.1	P&ID.....	8
3.2	Sommario delle condizioni operative e di progetto impianto.....	8
3.2.1	Caratteristiche dell'impianto.....	8
3.3	Disegni.....	9
3.4	Lista delle parti e certificati materiali.....	9
3.5	Documentazione sui componenti.....	9
3.6	Documentazione saldature.....	9
3.7	Documentazione sui controlli non distruttivi (NDT Test).....	9
3.8	Marcatura materiali e impianto.....	10
3.9	Dichiarazione di conformità al progetto.....	10
3.10	Dichiarazioni di conformità del processo di fabbricazione, installazione e prova idraulica.....	10
3.11	Certificato di prova idraulica.....	10
3.12	Certificato di conformità CE.....	11
3.13	Istruzioni operative.....	11
3.13.1	Avviamento.....	11
3.13.2	Iniezione di acqua fredda.....	12
3.13.3	Ciclaggio.....	12
4	MODIFICHE AL PROGETTO.....	13
4.1	Modifiche alle barre scaldanti.....	13
4.2	Modifiche al calcolo della circolazione naturale.....	13
4.3	Modifiche al calcolo del livello dello scambiatore principale.....	14
4.4	Modifiche al calcolo del ΔT barretta.....	14
4.5	Modifiche al calcolo del CHF.....	14
4.6	Modifiche alle valvole.....	15
4.7	Modifiche allo scambiatore principale.....	15
4.8	Modifiche alle prese di pressione e temperatura.....	15
4.9	Modifiche ai supporti delle barre e tenute.....	17
4.10	Modifiche alle connessioni con i sistemi ausiliari.....	21
4.11	Calcoli verifica condizioni operative.....	21
4.12	Modifiche ai supporti.....	40
4.13	Modifiche riguardanti la candela del pressurizzatore.....	40
4.14	Modifiche all'elenco delle misure.....	41
4.15	Modifiche alle misure di deformazione.....	45
4.16	Loop di regolazione.....	45
4.16.1	PIC-030 Pressione del circuito.....	45
4.16.2	LIC-030 Livello liquido nel pressurizzatore.....	45
4.16.3	JIC-050 Potenza termica allo scambiatore.....	46
4.16.4	FIC-040 Isolamento sistema iniezione di emergenza.....	46
4.16.5	WIC-100 Potenza elettrica al canale.....	47
4.17	Parametri di controllo.....	47
4.17.1	Minima pressione di impianto.....	48
4.17.2	Massima pressione di impianto.....	48
4.17.3	Massima pressione nel pressurizzatore.....	48
4.17.4	Massima temperatura delle barre scaldanti.....	48
4.17.5	Massima temperatura di uscita canale.....	48
4.17.6	Massima temperatura nel pressurizzatore.....	49
4.17.7	Livello liquido nel pressurizzatore.....	49
4.17.8	Minimo livello liquido scambiatore lato secondario.....	49
4.17.9	Massima corrente elettrica al canale di potenza.....	49
4.17.10	Massima corrente elettrica alla singola barra.....	49

4.17.11	Massimo potenziale elettrico al canale di potenza	50
4.17.12	Minimo potenziale elettrico tra canale di potenza e struttura impianto	50
4.17.13	Flussaggio scambiatore linea di iniezione EBT	50
4.17.14	Watchdog alimentazione elettrica strumenti	50
4.17.15	Watchdog SAED	50
4.17.16	Watchdog PLC	51
4.17.17	Watchdog regolatori di processo	51
4.18	Scelta classe resistenza tiranti flange impianto.....	51
5	RIFERIMENTI	53

Table

Tabella 2.1: Documentazione finale come richiesta nella Tabella 9.5.1 della norma EN13480-5	7
Tabella 4-1: Prese di pressione	16
Tabella 4-2: Prese di temperatura	17
Tabella 4-3 - Tensioni da creep AISI 304	30
Tabella 4-4: elenco misure dirette e strumenti	42
Tabella 4-5: elenco misure derivate	44
Tabella 4-6: caratteristiche flange e relativi bulloni	52
Tabella 4-7: carico di rottura per bulloni 8.8 e relative flange.....	52

Figure

Figura 1: Tenuta	18
Figura 2: "size" dei tubi, schedule di tubi e flange, posizione supporti	23
Figura 3: Caso 1, pressione 172.5 bar	25
Figura 4: Caso 2, pressione 100 bar	26
Figura 5: Caso 3, pressione 5 bar	27
Figura 6: Rappresentazione delle tensioni dovute a carichi di pressione, peso proprio del sistema e del suo contenuto, e carichi meccanici (SUS).....	31
Figura 7: Visualizzazione delle tensioni tenendo conto dei carichi termici con distribuzione di temperatura del caso 2 e pressione del caso 1	32
Figura 8: Simulazione di prova idraulica, con pressione pari a 1.43 volte la pressione del caso 1 e acqua a temperatura ambiente.....	33
Figura 9: Visualizzazione della tensione circonferenziale	34
Figura 10: Visualizzazione delle tensioni da creep	35
Figura 11: Visualizzazione degli spostamenti del circuito sotto effetto combinato del peso del sistema e del suo contenuto con distribuzione di temperature del caso 1 e pressione del caso 1	37
Figura 12: Visualizzazione degli spostamenti del circuito sotto effetto combinato del peso del sistema e del suo contenuto con distribuzione di temperature del caso 2 e pressione del caso 1	38
Figura 13: Visualizzazione degli spostamenti del circuito sotto effetto combinato del peso del sistema e del suo contenuto con distribuzione di temperature del caso 3 e pressione del caso 1	39

Allegati

Allegato 1	Lista materiali certificati: Disegno 074-00-01rev3 tav. 1, zona barre
Allegato 2	Lista materiali certificati: Disegno 074-00-01rev3 tav. 2, tratto uscita zona barre
Allegato 3	Lista materiali certificati: Disegno 074-00-01rev3 tav. 3, tratto orizzontale superiore
Allegato 4	Lista materiali certificati: Disegno 074-00-01rev3 tav. 4, tratto discendente
Allegato 5	Lista materiali certificati: Disegno 074-00-01rev3 tav. 5, esterno scambiatore
Allegato 6	Lista materiali certificati: Disegno 074-00-01rev3 tav. 6, venturimetro
Allegato 7	Lista materiali certificati: Disegno 074-00-01rev3 tav. 7, tronchetto a valle venturimetro
Allegato 8	Lista materiali certificati: Disegno 074-00-01rev3 tav. 8, tratto orizzontale inferiore
Allegato 9	Lista materiali certificati: Disegno 074-00-01rev3 tav. 9, EBT
Allegato 10	Lista materiali certificati: Disegno 074-00-01rev3 tav. 10, EBT scambiatore
Allegato 11	Lista materiali certificati: Disegno 074-00-01rev3 tav. 13, tenuta
Allegato 12	Documentazione valvola di sicurezza
Allegato 13	Documentazione venturimetro
Allegato 14	Documentazione valvola gate valve
Allegato 15	Documentazione valvole e manifold
Allegato 16	Documentazione valvole e manifold
Allegato 17	Qualifica saldatore interno (WPQ)
Allegato 18	Qualifica saldatore esterno (WPQ)
Allegato 19	Controllo visivo saldature
Allegato 20	Controllo dimensionale
Allegato 21	Dichiarazione di conformità al progetto
Allegato 22	Dichiarazione di conformità alla fabbricazione ed installazione
Allegato 23	Dichiarazione di conformità alla prova idraulica
Allegato 24	Certificato di prova idraulica
Allegato 25	Dichiarazione di conformità CE
Allegato 26	Specifica tecnica barre scaldanti primo fornitore
Allegato 27	Specifica tecnica barre scaldanti secondo fornitore
Allegato 28	Posizione termocoppie su barra scaldante per primo fornitore
Allegato 29	Posizione termocoppie su barra scaldante per secondo fornitore
Allegato 30	Calcolo ΔT barretta
Allegato 31	Specifica tecnica kalrez
Allegato 32	Calcoli strutturali e risultati con Autopipe Plus V8.i
Allegato 33	Specifica tecnica e disegno candela del pressurizzatore

Elenco disegni

074-00-00rev3:	Assieme generale
074-00-01rev3:	Dettagli (22 fogli)
074-00-02rev2:	Assieme inserito nella struttura (4 fogli)
074-01-00rev3:	Diagramma strumentato (2 fogli)
074-02-00rev3:	Schema di flusso (P&ID)

Nomenclatura

ASME	American Society of Mechanical Engineers
CE	marcatore per la libera circolazione dei prodotti fabbricati nella comunità europea
CHF	Critical Heat Flux
DN	Diametro nominale della tubazione
EBT	Emergency Boration Tank
E/P	Electro/pneumatic converter (convertitore elettropneumatico);
HP	High pressure
Hot Rod	barra scaldante simulazione dell'elemento di combustibile di potenza maggiorata
IRIS	International Reactor Innovative and Secure
LP	Low Pressure
Normal rod	barra scaldante simulazione dell'elemento di combustibile di potenza standard
NRC	Nuclear Regulatory Commission
PED	Pressure Equipment Directive
PID s.a.	Proportional Integrative, Derivative single action (regolatore di processo ad azione proporzionale, integrativa e derivativa ad azione singola);
PID d.a.	Proportional Integrative, Derivative double action (regolatore di processo ad azione proporzionale, integrativa e derivativa ad azione doppia);
PLC	Programmable Logical Controller (controllore logico programmabile);
PRZ	Pressurizzatore
PS	Pressione di progetto
PWM	Pulse Width Modulation (modulazione ad ampiezza di impulso);
PWR	Pressurized Water Reactor
RPV	Reactor Pressure Vessel
SAED	Sistema di Acquisizione ed Elaborazione Dati;
SCR	Silicon Controlled Rectifier (raddrizzatore controllato al silicio);
SIET	Società Informazioni Esperienze Termoidrauliche
SPES	Simulatore Pressurizzato per Esperienze di Sicurezza
SPES-3	Impianto sperimentale modello in scala di IRIS
SSR	Solid State Relè (relè allo stato solido);
TEE	Raccordo sagomato a "T"
TS	Temperatura di progetto
UNI	Ente Nazionale Italiano di Unificazione
V	Volume interno netto di un recipiente, raccordi compresi fino alla prima connessione
WATCHDOG	Segnale logico rilevatore di anomalia
WPQ	Welder Procedure Qualification

1 INTRODUZIONE

Il presente documento illustra “as built” l’impianto sperimentale denominato “Circuito Prova Barre”, includendo il processo di realizzazione che ha preso avvio dal progetto esecutivo, documento 01510RT09rev0 [1].

Esso rappresenta il dossier della documentazione finale, che precede la messa in servizio (commissioning) dell’impianto, poiché ne raccoglie e riassume tutti i componenti di progetto e costruzione, secondo quanto previsto dalla norma UNI EN 13480-5.

In esso sono evidenziati i cambiamenti effettuati in corso d’opera, sia a livello progettuale che esecutivo, rispetto a quanto stabilito nel documento di progetto.

Costituiscono parte integrante del documento tutti gli allegati e i disegni riportati in coda, essenzialmente revisioni aggiornate dei disegni presenti nel documento di progetto.

2 CONTENUTI DEL DOCUMENTO

Il documento contiene, come allegati, tutti i documenti che costituiscono il dossier della documentazione finale, eventualmente preceduti da un breve commento esplicativo.

Il contenuto è quello previsto dalla Tabella 9.5.1 della norma EN13480-5, in ottemperanza alla direttiva PED 97/23/CE, per la Categoria 1 di appartenenza del circuito, secondo quanto stabilito nel paragrafo 3.1 di [1]. Per completezza riportiamo in Tabella 2.1 lo stralcio della Tabella 9.5.1 della norma EN13480-5, per le sole categorie applicabili al progetto.

Tabella 2.1: Documentazione finale come richiesta nella Tabella 9.5.1 della norma EN13480-5

No.	Documents	Clause	Piping class	Piping below 0,5 bar
			I	
1	Piping and instrumentation diagram (P & I diagram)	6.2	x	
2	Summary of design and operating conditions		x	X (a)
3	Drawings of the layout of the piping and piping supports with dimensions, (may include isometric drawings, as built drawings, views, ground layouts)	6.2 6.3.1	x	X (a)
4	Parts lists for piping components with dimensions, standards, materials	6.2	x (a)	X (a)
5	Material certificates for base materials and welding consumables, if required	7.2.2	x (a)	–
6	Documentation for miscellaneous components, e.g. valves, safety equipment	6.3.1	x (a)	–
7	Welding documents	6.2.3	x (a)	X (a)
8	NDT documents	6.2.2 8.8	x	–
9	Heat treatment documents	6.2.2	x	–
10	Pressure test or equivalent test documents	6.2.2	x	–
11	Marking information	EN 13480-4: 2002, 11.2	x	–
12	Declaration of design compliance	6.5	x	X (a)
13	Declaration of compliance for piping fabrication/installation	10	x	–
14	Pressure test certificate	9.3.4	x	–
15	Declaration of compliance	10	x	–
16	Operating instructions	9.5.3	x	–
(a) dependant on manufacturer's decision				

Nota: Come rilevabile dalla colonna 4 della Tabella 2.1, alcune parti della documentazione sono opzionali, e contrassegnate in colonna dal simbolo (a). Tra queste, in particolare, con riferimento alla colonna 1, sono state omesse la No. 4 per le parti del circuito non direttamente connesse a parti in pressione, la No. 5 per le parte materiali di saldatura, mentre la No. 6 comprende la sola documentazione disponibile.

3 DETTAGLI CONTENUTO DOCUMENTI RICHIESTI

3.1 P&ID

Il disegno 074-02-00rev1 è stato aggiornato, ed emesso in rev3. In particolare vi sono state variazioni sui loop di regolazione e sui sistemi ausiliari. Per maggiori dettagli si rimanda ai paragrafi 4.10 e 4.16 del presente documento.

3.2 Sommario delle condizioni operative e di progetto impianto

Le caratteristiche dell'impianto rimangono le stesse descritte nel par. 4.2 di [1] e vengono riportate per completezza. Come si vede, l'unica differenza è rappresentata dalla massima potenza elettrica delle barre, che si è deciso essere di 121 kW, in quanto generata da due "Normal rods" da 27612 W e due "Hot Rods" da 33135 W.

3.2.1 Caratteristiche dell'impianto

L'impianto "Circuito prova barre" è costituito da un circuito principale che ospita le barre, da uno scambiatore, da un circuito di simulazione dell' EBT e da un pressurizzatore cilindrico collegato all'impianto mediante una linea di disaccoppiamento idraulico e contenente una delle candele scaldanti previste su SPES-3. L'impianto è progettato per soddisfare le seguenti condizioni di esercizio:

- volume di acqua nel circuito principale 0.0325 m³; di cui 0.0035 m³ nel pressurizzatore
- volume di acqua nel circuito EBT 0.005 m³;
- Pressione di progetto 17.25 Mpa
- Temperatura di progetto 353.5 °C (T saturazione)
- Pressione di esercizio 15.5 Mpa
- Temperatura di ingresso acqua in esercizio 278 °C
- Temperatura di uscita acqua in esercizio 316 °C
- Salto termico ingresso-uscita ΔT 38 °C
- massima potenza elettrica alle barre 121 kW (2 standard rods da 27612 W, 2 hot rod da 33135 W)
- Resistenza del Pressurizzatore 25 kW
- massima portata massica nel primario 0.54 kg/s

Il fluido di processo è acqua demineralizzata. Il circuito principale opera in circolazione naturale.

Le condizioni di progetto per il circuito principale sono quelle del primario SPES-3, quelle di esercizio sono leggermente diverse, pur conservando il salto termico tra ramo caldo e freddo di SPES-3. Le differenze sono evidenziate nel paragrafo 4.2.

Il circuito EBT verrà usato per test di shock e ciclaggio termico sulle barre di potenza.

3.3 Disegni

I disegni sono stati aggiornati e l'elenco è presentato all'inizio del presente documento.

3.4 Lista delle parti e certificati materiali

Il disegno d'assieme 074-00-00rev3 contiene la lista delle parti nel cartiglio.

I disegni delle parti, indicati in 074-00-01rev3, tavole da 1 a 13, hanno la loro lista materiali. Di queste, le tavole 11 e 12 del disegno 074-00-01rev3 non propongono una lista materiali poiché la prima rappresenta le valvole principali del sistema e i particolari della seconda sono già inseriti in altre liste materiali.

Per ogni parte in pressione sono stati compilati gli allegati, da 1 a 11, "lista materiali certificati", che fanno riferimento alle tavole del disegno 074-00-01rev3, con i relativi certificati materiali.

3.5 Documentazione sui componenti

La documentazione relativa al venturimetro, alla valvola di sicurezza e di regolazione sono riportate negli allegati, da 12 a 14. In particolare, la documentazione su:

- la valvola di sicurezza, certificata PED, è riportata nell'allegato 12;
- il venturimetro, certificato PED, nell'allegato 13;
- la valvola da 2 pollici di regolazione, certificata PED, nell'allegato 14.

Gli altri componenti, quali strumenti di misura della pressione differenziale, strumenti di misura della pressione relativa, le termocoppie per la misura della temperatura di fluido e i due pressostati sono stati tarati e i relativi certificati sono presenti nel raccoglitore denominato DRF presso gli uffici SIET, a Piacenza.

Per le valvole di sfiato, di iniezione, di alimento e di drenaggio ed i manifold utilizzati per i misuratori di pressione, collegati al circuito principale in pressione, i certificati di conformità sono riportati negli allegati 15 e 16.

3.6 Documentazione saldature

I certificati WPQ (welder procedure qualification) del saldatore interno e del saldatore esterno sono riportati rispettivamente negli allegati 17 e 18.

3.7 Documentazione sui controlli non distruttivi (NDT Test)

L'entità dei controlli era stata stabilita, secondo normativa, nel capitolo 12 di [1].

Nel raccoglitore DRF, archiviato presso gli uffici SIET, sono presenti:

- le radiografie delle saldature conformi

- i report radiografici delle saldature conformi
- le radiografie delle saldature non conformi
- le radiografie delle saldature riparate
- i report radiografici delle saldature riparate
- i disegni che mostrano i riferimenti delle saldature da verificare e da riparare.

L'allegato 19 e l'allegato 20 riportano rispettivamente i risultati del controllo visivo e del controllo dimensionale. I risultati dei controlli non distruttivi dimostrano la conformità dell'impianto rispetto alla normativa.

3.8 Marcatura materiali e impianto

I numeri di colata, ricavati dalla lista materiali, sono stati apposti sugli spezzoni di tubazione, qualora non sia presente o non visibile la marcatura di fabbrica. Tale marcatura è stata fatta tramite penna elettronica.

Fittings e flange hanno la marcatura stampigliata individualmente dal fabbricante.

Sull'intero impianto è stata apposta la targa a disegno 074-00-01rev4 Tav 14 con la marcatura CE come definito nel par. 4.7.1 di [1].

3.9 Dichiarazione di conformità al progetto

L'allegato 21 riporta la dichiarazione di conformità del progetto ai requisiti della norma EN13480.

I disegni di riferimento, rilevanti al fine della verifica della dichiarazione, sono elencati all'inizio del documento e riportati in calce.

3.10 Dichiarazioni di conformità del processo di fabbricazione, installazione e prova idraulica

L'allegato 22 riporta la dichiarazione di conformità del processo di fabbricazione ed installazione secondo i requisiti della norma EN13480.

L'allegato 23 riporta il certificato di conformità dell'impianto alla prova idraulica secondo la norma EN13480.

3.11 Certificato di prova idraulica

L'allegato 24 presenta il certificato di prova idraulica, con specificati

- la temperatura a cui è avvenuto il test,
- la pressione di prova,
- la durata della prova,

- la verifica della tenuta del sistema,
- il risultato,
- l'esecutore della prova.

3.12 Certificato di conformità CE

L'allegato 25 presenta la dichiarazione di conformità del progetto ai requisiti CE, secondo quanto previsto dal modulo A della PED e specificato al par. 3.1 di [1].

3.13 Istruzioni operative

Le istruzioni operative non hanno subito variazioni rispetto a quelle riportate nel paragrafo 4.3 di [1] e vengono riportate integralmente.

3.13.1 Avviamento

Nelle condizioni di start-up si parte con l'impianto completo degli internals, riempito di acqua (fino al livello previsto nel pressurizzatore, che corrisponde ad 1/3 della sua altezza), a pressione atmosferica $P=1$ bar e $T_{\text{acqua}} = T_{\text{amb}} = 10-20$ °C, in dipendenza delle condizioni atmosferiche esterne. L'assenza di contropendenze favorisce l'eliminazione dell'aria contenuta nelle tubazioni. Anche gli scambiatori vengono riempiti con acqua a temperatura ambiente, fino al livello nominale. Una volta riempito il circuito, la pressurizzazione del sistema è ottenuta portando a saturazione l'acqua contenuta nel circuito del pressurizzatore, mediante la candela scaldante da 25 kW inserita nel pressurizzatore stesso.

In alternativa è possibile pressurizzare con azoto, tramite la linea di iniezione presente sulla sommità del pressurizzatore.

Il riscaldamento dell'acqua nel circuito principale può essere avviato contemporaneamente alla pressurizzazione, dando potenza alle barre scaldanti principali (le barre sottoposte a collaudo).

Il riscaldamento dell'acqua avviene gradualmente, la temperatura dell'acqua in uscita dovrà essere minore della temperatura all'interno del pressurizzatore, per evitare la formazione di sacche di vapore.

La differenza di densità che si crea tra l'acqua presente nel ramo caldo e quella nel ramo freddo favorisce l'instaurarsi di una portata di circolazione naturale nel circuito, che porta ad un rapido miscelamento dell'acqua. Lo scambio termico con le barre di potenza fa aumentare gradualmente la temperatura dell'acqua all'uscita del ramo caldo rispetto a quella di ingresso, l'aumentata temperatura dell'acqua nel circuito discendente favorisce lo scambio termico con lo scambiatore sul primario, che la raffredda facendo così aumentare il ΔT dell'acqua tra ingresso ed uscita dal canale caldo, fino ad arrivare, modulando opportunamente i parametri (pressione, temperature, livello nello scambiatore), alle condizioni di esercizio volute.

Nel circuito principale, alle condizioni operative, scorre acqua sottoraffreddata, alla pressione di esercizio di 155 bar ed alla temperatura massima di esercizio di 316 °C, con un ΔT tra ingresso ed uscita dal canale caldo di 38 °C.

3.13.2 Iniezione di acqua fredda

Il circuito che simula l'EBT è un circuito secondario di bypass al ramo discendente del circuito principale, ed in condizioni operative di impianto in esso è contenuta acqua ferma a temperatura ambiente ed alla pressione di impianto di 155 bar. Questa riserva di acqua fredda può essere iniettata per gravità nel flusso principale, semplicemente aprendo la valvola a sfera posta nella parte inferiore.

L'iniezione può essere completa, ed in questo caso la valvola a sfera viene mantenuta aperta per un tempo prolungato, oppure può essere parziale. In questo secondo caso la valvola a sfera viene mantenuta aperta per un lasso temporale più limitato, in modo di consentire il trasferimento solo parziale della massa di acqua fredda contenuta nell'EBT.

L'acqua calda proveniente dal circuito principale, che sostituisce quella fredda all'interno dell'EBT, viene raffreddata, successivamente alla richiusura della valvola, dallo scambiatore coassiale che circonda l'EBT stesso.

Nel secondario di tale scambiatore viene immessa all'occorrenza una portata costante di acqua fredda. L'acqua eccedente il livello previsto viene scaricata attraverso il troppo pieno ed allontanata. Il secondario dello scambiatore, successivamente all'iniezione dell'EBT nel circuito principale, sarà sottoposto ad un flussaggio continuo di acqua a temperatura ambiente, allo scopo di riportare, entro breve tempo, l'acqua all'interno del circuito EBT ad una temperatura $T < 40$ °C.

3.13.3 Ciclaggio

Per simulare il funzionamento delle barre in condizioni operative saranno realizzati dei cicli, che riproducono il comportamento delle barre sull'impianto SPES-3.

I cicli saranno composti dalla seguente successione di modalità operative:

- 1) riscaldamento da temperatura ambiente alle condizioni operative,
- 2) raggiungimento delle condizioni di regime (pressione, temperatura, potenza nominali),
- 3) spegnimento della candela di riscaldamento del pressurizzatore,
- 4) apertura di uno sfiato per simulare la depressurizzazione,
- 5) ad un determinato valore di pressione, riduzione a zero della potenza e immediata riaccensione al 10% della potenza nominale,
- 6) apertura della valvola di iniezione dell'EBT per introdurre un flusso di acqua fredda,
- 7) attesa del raggiungimento delle condizioni di pressione di 5-6 bar;
- 8) mantenimento della potenza al 10% e della pressione a 5-6 bar fino allo scoprimento della estremità delle barre, rilevato dall'incremento della temperatura di estremità delle barre stesse, fino al valore limite definito in specifica [2];
- 9) Spegnimento totale delle barre ed attesa che la temperatura del circuito diminuisca sotto i 40-50 °C.

Il numero totale di ciclaggi previsti nella vita dell'impianto (<1000), non giustifica (in ottemperanza alla norma EN 13480:3 par. 4.6) una verifica a fatica dei componenti dell'impianto.

4 MODIFICHE AL PROGETTO

4.1 Modifiche alle barre scaldanti

Le barre scaldanti da testare nell'impianto sono state realizzate secondo la specifica tecnica [2].

La principale differenza rispetto alla fase di progettazione è la scelta di testare due "Normal rods" di potenza 27612 W e due "Hot Rods" da 33135 W, per una potenza complessiva di 121494 W.

Le barre scaldanti sono state acquistate da due aziende diverse, ognuna delle quali fornisce due set da quattro barre. L'intenzione è poi quella di valutare separatamente, con due campagne sperimentali distinte, ma alle stesse condizioni, le barre dei due diversi fornitori al fine di scegliere il prodotto che meglio risponde alla specifica tecnica.

In allegato 26 e 27 sono riportate le specifiche tecniche dei due costruttori.

Nonostante la tecnologia di realizzazione sia differente, la geometria esterna e le caratteristiche tecniche sono le medesime per i due set, il che permette di valutare le prestazioni nello stesso impianto. L'unica differenza rilevabile è la presenza di quattro termocoppie incluse in ciascun elemento scaldante per un fornitore e di una per l'altro, come indicato rispettivamente negli allegati 28 e 29. Gli allegati riportano anche la quota degli strumenti.

Gli studi e i calcoli effettuati in SIET hanno evidenziato che le barre possono presentare il problema del surriscaldamento dei cavi elettrici di connessione alle barre scaldanti, soprattutto nella configurazione finale di SPES3, in cui ci saranno 235 barre scaldanti separate da 3 mm. Uno dei due costruttori ha risolto il problema, dopo diversi colloqui con i tecnici SIET, utilizzando i coltelli di supporto assiale delle barre, indicate con il numero 15 nel disegno 074-00-00rev3, come conduttore (polo) e conseguente cambiando il suo materiale, da acciaio a rame.

4.2 Modifiche al calcolo della circolazione naturale

Il cambiamento della potenza da smaltire provoca un cambiamento della portata che si viene a generare per circolazione naturale.

La portata prototipica è di 0.579 Kg/s, scalata dalla portata su SPES3, secondo i seguenti calcoli:

La potenza di SPES3 è di 6.50 MW, la portata data dalla pompa è di 31.01 kg/s. L'acqua lambendo le barre subisce un aumento di temperatura di 38°C. Con due "Hot Rods" e due "Normal Rods" il fattore di scalatura dell'impianto risulta essere:

$$\text{Fattore di scala} = \frac{121494}{6500000} = 0.0187$$

Quindi la portata scalata teorica risulta essere

$$\dot{m}_{\text{scalata}} = 0.0187 * 31.01 = 0.579 \text{ kg / s}$$

La portata necessaria per asportare l'energia delle barre è data dalla formula:

$$W = \dot{m} \cdot C_p \cdot \Delta T$$

Poiché la variazione di temperatura deve rimanere la stessa, quindi di 38°C, la portata del circuito risulta essere:

$$\dot{m} = \frac{W}{C_p \cdot \Delta T} = \frac{121494}{5500 \cdot 38} = 0.581 \text{ kg/s}$$

Quindi in perfetto accordo, anche se leggermente maggiore della portata teorica calcolata, pari a 0.579 kg/s.

L'allegato 3 al documento [1], "calcolo circolazione naturale", non cambia nella sostanza, anche se a causa dell'aumento della potenza cambiano leggermente, oltre alla portata, le perdite di carico.

4.3 Modifiche al calcolo del livello dello scambiatore principale

L'aumento di potenza richiede un aumento del livello dell'acqua di raffreddamento presente nello scambiatore principale. Nel calcolo effettuato in sede di progetto si aveva un livello di 3.67 m, quanto l'altezza disponibile dello scambiatore è di 4.10 m disponibili. Nella nuova configurazione sono richiesti circa 25 cm in più, fino a raggiungere i 3.95 m.

L'allegato 4 al documento [1], "verifica dello scambiatore principale" rimane inalterato, eccetto che per l'aumento di livello.

4.4 Modifiche al calcolo del ΔT barretta

L'aumento della potenza delle barre richiede anche una verifica della temperatura di parete raggiunta dalla barretta, per verificare che sia prototipica con le condizioni di SPES3 e che non superi i limiti imposti. In sedi di progettazione i calcoli sono stati riportati nell'allegato 1 di [1].

Nel circuito prova barre l'acqua viene portata da 278°C a 316°C con un delta di temperatura pari a 38°C. Nell' allegato 30 è stato calcolato che la parete della barretta raggiunge in media la temperatura di 324.63°C con la potenza di 121494 W, mentre con la potenza generata da 3 barre "Normal" ed una "Hot", raggiungeva 324.37°C. Il valore di riferimento di SPES3 è di 322.71°C.

L'aumento in potenza non ha dunque portato ad alcun cambiamento; la significatività delle prove, descritta nel capitolo 5 di [1], è quindi confermata.

4.5 Modifiche al calcolo del CHF

La nuova configurazione scelta per le barre riscaldanti, con il conseguente aumento di potenza, richiede di verificare che sulla superficie laterale non si superi mai il flusso di calore critico o Critical Heat Flux (CHF).

Il CHF, calcolato in sede di progetto e indicato nell'allegato 2 di [1], è di 564000 W/m².

Con l'aumento di potenza il flusso imposto dalle barre riscaldanti è:

$$Flusso = 121494 / 0.500323 = 242831 \text{ W/m}^2$$

Quindi si è largamente al di sotto del flusso critico.

4.6 Modifiche alle valvole

È stato deciso in sede di realizzazione di non differenziare le valvole di alimentazione, sfiato e drenaggio ad alta pressione da quelle previste per bassa pressione. In sede di progettazione sono state scelte per la parte ad alta pressione e temperatura del circuito valvole con pressione di progetto di 172.5 bar e temperatura di progetto 353.5°C, mentre nella parte a bassa pressione sono state previste valvole con pressione di progetto di 2 bar e temperatura di progetto 120°C.

In fase di realizzazione si è deciso di acquistare valvole ad alta pressione e temperatura ed installarle anche nelle parti a bassa pressione.

4.7 Modifiche allo scambiatore principale

Come indicato nell'allegato 5 di [1], l'impianto richiede un serbatoio che separi le gocce trascinate dalla fase vapore durante il funzionamento. Una schematizzazione del serbatoio è presente nel disegno 074-03-00rev0. Il serbatoio è stato realizzato ed è riportato nei disegni del presente documento.

La presenza del serbatoio ha portato allo spostamento della misura di livello dello scambiatore, che non viene più effettuata sullo scambiatore ma sul serbatoio. L'iniezione dell'acqua di alimento dello scambiatore e l'uscita del vapore avvengono entrambe dal serbatoio.

4.8 Modifiche alle prese di pressione e temperatura

Le principali modifiche sulle prese di pressione e temperatura sono indicate nei disegni, in particolare nelle due tavole di 074-01-00rev3.

In generale le quote e la posizione delle prese è stata rispettata. Le prese di pressione M4, M5 e di temperatura T4, previste in prossimità di raccordi sagomati a "T" (TEE), sono state spostate di circa 20 mm a causa della saldatura a tasca dei componenti.

Sono state aggiunte le prese di pressione M3a nella parte alta del tratto ascendente del circuito principale e le prese di pressione M52 e M53 nel serbatoio collegato allo scambiatore principale per la misura di livello.

Sono state eliminate le prese di pressione M40 sulla parte superiore del circuito dell'EBT, in quanto non necessaria ai fini delle misurazione e le prese M7 ed M8, sullo spezzone del venturimetro, anch'esse non necessarie.

È stata aggiunta la presa di temperatura T3a nella parte alta del tratto ascendente del circuito principale. La presa di temperatura T6 è stata spostata dal tratto del venturimetro a quello immediatamente sotto.

Gli elenchi delle prese di pressione e di temperatura con le relative elevazioni e descrizione sono riportati rispettivamente in Tabella 4-1 e Tabella 4-2.

Tabella 4-1: Prese di pressione

descrizione	codice	quota
circuito primario quota inferiore barre	M1	1.200
circuito primario quota mediana barre	M2	4.244
circuito primario quota superiore barre	M3	7.087
circuito primario quota superiore tratto ascendente	M3a	9.231
circuito primario ascendente quota superiore	M4	9.800
circuito primario discendente quota superiore	M5	9.662
uscita scambiatore lato primario	M6	4.729
Circuito primario lato discendente zona bassa	M9	3.053
circuito primario discendente quota inferiore	M10	2.025
circuito primario iniezione linea di ritorno	M11	1.200
monte venturimetro	M20	4.165
valle venturimetro	M21	4.065
quota inferiore pressurizzatore	M30	10.268
quota mediana pressurizzatore	M31	12.377
quota superiore pressurizzatore	M32	14.341
uscita linea iniezione scambiatore EBT	M41	5.821
linea iniezione EBT quota inferiore	M42	2.186
Linea orizzontale iniezione EBT	M43	0.850
scambiatore circuito primario lato secondario quota superiore	M50	8.622
scambiatore circuito primario lato secondario quota inferiore	M51	4.839
Quota superiore vaschetta di raccolta scambiatore principale	M52	9.681
Quota inferiore vaschetta di raccolta scambiatore principale	M53	8.881

Tabella 4-2: Prese di temperatura

descrizione	codice	quota
circuito primario quota inferiore barre	T1	1.200
circuito primario quota mediana barre	T2	4.244
circuito primario quota superiore barre	T3	7.087
circuito primario quota superiore tratto ascendente	T3a	9.231
circuito primario discendente quota superiore	T4	9.662
uscita scambiatore lato primario	T5	4.729
circuito primario lato discendente zona bassa	T6	3.053
circuito primario lato discendente quota inferiore	T7	2.025
circuito primario iniezione linea di ritorno	T8	1.200
quota inferiore pressurizzatore	T30	10.268
quota mediana pressurizzatore	T31	12.377
quota superiore pressurizzatore	T32	14.341
uscita linea iniezione scambiatore EBT	T41	5.821
linea iniezione EBT quota inferiore	T42	2.186
scambiatore circuito primario lato secondario quota superiore	T50	8.622
scambiatore EBT lato secondario quota mediana	T60	7.700

Le variazioni relative alle prese di pressione e temperature installate nella zona della tenuta vengono descritte nel paragrafo 4.9, dedicato alle modifiche della tenuta.

4.9 Modifiche ai supporti delle barre e tenute

I supporti delle barre, che mantengono gli elementi scaldanti in posizione lungo il tubo verticale, correttamente distanziati gli uni dagli altri e dalla superficie interna del tubo, sono rappresentati da 15 griglie, il cui particolare è contenuto nel disegno 074-00-00rev3. Nel progetto delle griglie non ci sono state variazioni. Poiché le tolleranze di fabbricazione richieste su questi elementi sono spinte e vista la particolarità dei pezzi, soprattutto in previsione della realizzazione delle griglie per 236 barre, si è deciso di sperimentare diversi fornitori con differenti caratteristiche tecniche. Le griglie sono state tutte realizzate in acciaio INOX. Sono state provate tre differenti modalità di taglio:

- taglio laser,
- taglio per elettroerosione,
- taglio ad acqua.

Durante le prove sarà possibile verificare le griglie realizzate dai diversi costruttori, per individuare quelle che meglio rispondono alle esigenze tecniche, anche dall'analisi dimensionale e dalla finitura superficiale, le griglie tagliate per elettroerosione sembrano essere le più adatte.

La tenuta, descritta in [1] al paragrafo 4.1.4, ha subito delle lievi modifiche dovute alla necessità di asportare il calore generato nella parte non attiva delle barre, tra l'attacco dei cavi e l'inizio della parte attiva.

Secondo Rotfil (una delle due aziende concorrenti per la realizzazione delle barre scaldanti) le barre vanno a dissipare nella loro parte inattiva, lunghezza L quotata in Figura 1, 104.5 W ciascuna. Considerando che in SPES3 il numero di barre è pari a 236, il calore disperso dal pacco barre è pari a circa 25 kW: ciò implica la necessità di adottare un sistema di raffreddamento per i componenti del gruppo tenuta.



Figura 1: Tenuta

Nel circuito prova barre, data la presenza di solo 4 barre, la potenza totale da asportare è di circa 420 W, che si è deciso di asportare modificando il gruppo tenuta.

La Figura 1 mostra che la parte non attiva delle barre, non bagnata dall'acqua dell'impianto, può essere suddivisa in tre zone, in cui le barre sono a contatto con la parte metallica della tenuta:

1. La parte superiore, identificata dalla lettera A. Poiché la flangia di centraggio, particolare 2, ha la parte alta lambita dall'acqua del circuito, si è deciso di utilizzare tale fluido per asportare il calore di questo tratto. Il diametro dei fori di alloggiamento delle barre è passato da 9.5 mm (diametro nominale delle barre) a 9.8 mm per permettere all'acqua di salire lungo gli elementi. Poiché la parte inferiore della flangia di centraggio è a contatto con il primo pacco di tenute, formato da rondelle di grafite ed acciaio, si è creato in questa zona un anello di raccolta dell'acqua e si sono realizzate due scanalature che percorrono assialmente tutto il particolare 2 (tavola 19 del disegno 074-00-01rev3), in modo da permettere all'acqua calda di scendere per alimentare la circolazione naturale. Per verificare il raffreddamento e la circolazione del fluido sono state realizzate due prese di temperatura a metà altezza della barra forata, particolare 82.

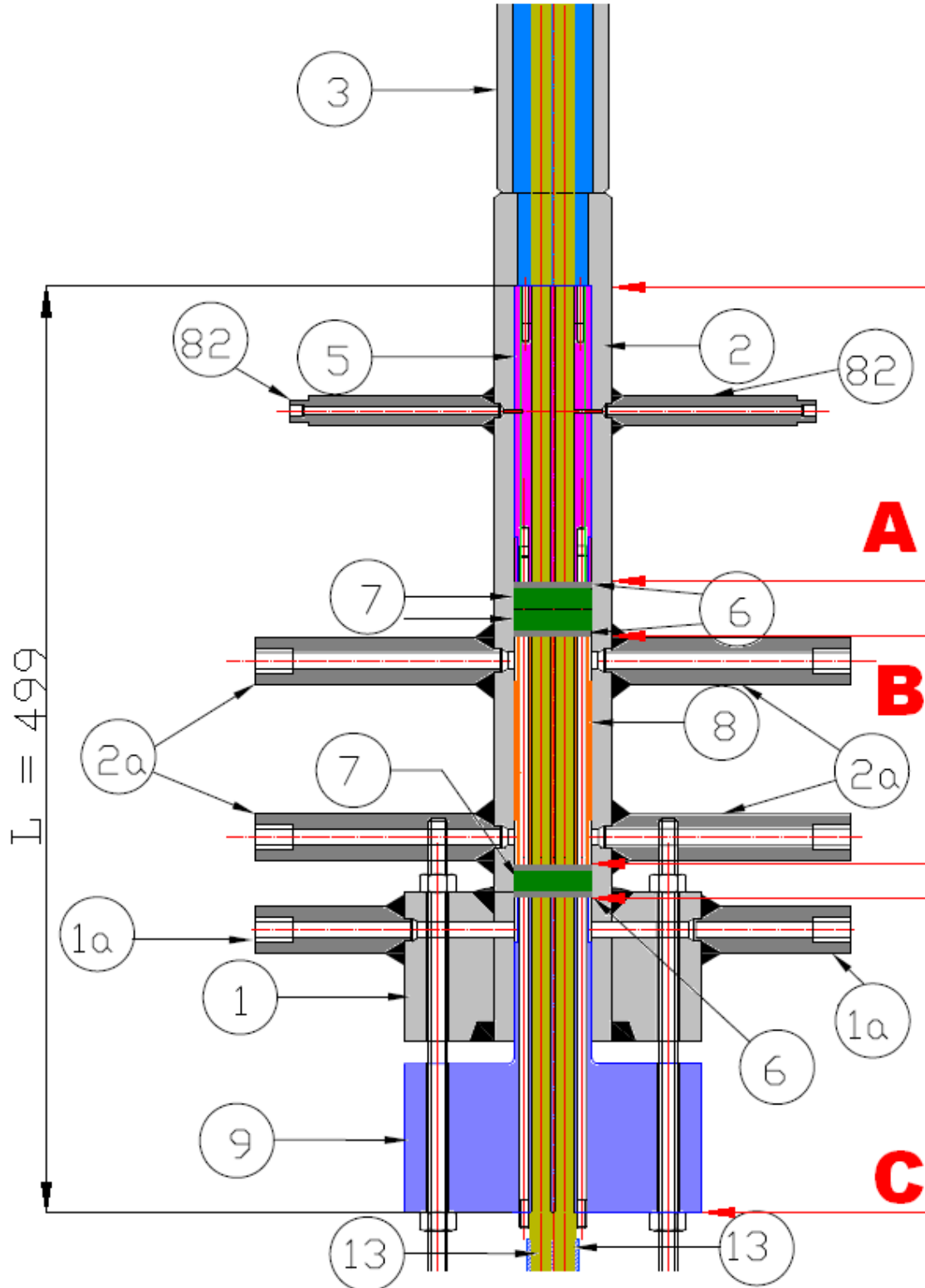
2. La parte centrale, identificata dalla lettera B. Questa zona rappresenta la parte più critica, poiché è racchiusa tra il primo pacco di tenute (in alto) ed il secondo pacco di tenute (in basso), quindi è necessario utilizzare un sistema di raffreddamento a circolazione forzata. Per questo l'anello di tenuta interno, particolare 8, che in sede di progetto aveva una scanalatura per valutare le eventuali perdite di fluido del pacco tenuta superiore, è stato modificato in modo da permettere il raffreddamento. Il diametro di alloggiamento delle barre è stato portato da 9.5 mm a 9.8 mm e sono stati realizzati, sia nella parte superiore, sia nella parte inferiore, due anelli di raccolta con due scanalature longitudinali che permettono al fluido di raggiungere le barre. Il refrigerante, che può essere sia acqua, sia aria, è immesso attraverso una presa di pressione, particolare 2a, saldata al particolare 1 in corrispondenza della parte alta dell'anello di tenuta; il fluido lambisce le barre dall'alto verso il basso ed esce da un'altra presa di pressione (tavola 21 del disegno 074-00-01rev3). Le prese di pressione fungono da bocchelli di ingresso e uscita, con diametro interno di 9 mm, e permettono l'inserimento di termocoppie per verificare lo scambio di calore. Sono previste due termocoppie, una nella parte alta ed una nella parte bassa dell'anello di tenuta.

È possibile verificare il funzionamento del primo pacco tenuta, ovvero l'assenza di perdite d'acqua dal circuito principale, valutando che la portata d'acqua in ingresso per raffreddare sia la medesima in uscita, in caso di acqua come fluido, o valutando la presenza di vapore nell'aria in uscita, in caso di aria come fluido refrigerante.

La portata richiesta di acqua o aria è la seguente:

$$\dot{m} = \frac{W}{c_p \cdot \Delta T}$$

dove:

- W è la potenza da smaltire nel tratto interessato, equivalente a quella dispersa dalle barre scaldanti, pari a circa 120 W;
- ΔT è la differenza di temperatura del fluido di raffreddamento, che è dell'ordine di 30 °C con acqua e di 100°C circa con aria compressa.

La portata risultante si aggira su un valore molto basso sia utilizzando acqua, sia aria compressa: circa 3 kg/h con acqua, circa 5 kg/h con aria compressa a 6 bar; in fase di prova si valuterà quale delle due soluzioni adottare per il raffreddamento del componente.

3. La parte inferiore, identificata dalla lettera C. La flangia di chiusura, particolare 9, ha la parte alta a contatto con il pacco tenuta inferiore, mentre la parte bassa è aperta verso l'atmosfera. In questo componente sono state realizzate piccole modifiche per permettere il raffreddamento: nella parte alta del pezzo è stato realizzato un anello di raccolta con scanalatura longitudinale, in modo che il fluido refrigerante, immesso dalla parte alta attraverso una presa di pressione, particolare 1a, possa raggiungere gli elementi scaldanti. Il diametro di alloggiamento delle barre è stato portato da 9.5 mm a 9.8 mm per permettere al fluido di lambire le barre ed uscire in atmosfera dalla parte bassa. Il fluido refrigerante in questa zona è aria. Le prese di pressione possono ospitare le termocoppie per valutare lo scambio termico. Vi è anche un'altra sede per una termocoppia che può essere posta nella parte bassa della flangia di chiusura (tavola 18 del disegno 074-00-01rev3).

Questo tratto, cui corrisponde una potenza da smaltire di circa 150 W, viene raffreddato con aria compressa (la pressione è pari a 6 bar, tipica dell'alimento dei servizi impianto); la portata risultante di aria è circa 6 kg/h con una velocità di 4 m/s.

Le dimensioni dei fori e l'altezza delle scanalature scelte non comportano perdite di carico elevate: dai calcoli effettuati ammontano a 52 kPa, tutti imputabili alle perdite distribuite lungo il gap tra foro e barretta avente dimensione massima di 0.3 mm, come richiesto dalle tolleranze di lavorazione.

A causa di questo margine minimo, il sistema di raffreddamento potrebbe presentare delle criticità nella parte superiore (A) dovute all'eventuale formazione di sacche di vapore. L'alta resistenza idraulica che incontra l'acqua lungo il percorso nello spazio tra barretta e foro, nella flangia di centraggio e nell'anello di tenuta, può portare allo scarso bagnamento delle pareti.

In questa situazione, il continuo ricircolo di acqua continuamente a contatto con le pareti porterebbe alla formazione di vapore con occlusione dello spazio e aumento considerevole della temperatura locale, fino a degenerare nella bruciatura del componente della tenuta interessato dall'evento. Per scongiurare questo, sono previsti alloggiamenti per inserimento di termocoppie in modo da tenere sotto controllo la temperatura dell'acqua, come sottolineato in precedenza.

Anche altri elementi della tenuta hanno subito delle modifiche. Il particolare 1, descritto nella tavola 20 del disegno 074-00-01rev3 è stato modificato dall'aggiunta di 6 prese di pressione e 2 prese di temperatura. Gli anelli di acciaio che proteggono gli anelli di grafite del pacco tenuta, particolare 6, descritti nella tavola 16 del disegno 074-00-01rev3, hanno il diametro dei fori di alloggiamento delle barre di 9.8 mm e non più di 9.5 mm. I coltelli distanziatori, indicati con 15 nel disegno 074-00-00rev3, hanno le stesse dimensioni e geometria, ma sono realizzati in rame, poiché rappresentano un polo delle barre scaldanti, come indicato in precedenza.

Anche gli anelli di grafite, componenti fondamentali del processo di tenuta, hanno subito alcuni cambiamenti. Secondo il progetto la tenuta è garantita da due anelli di grafite, ciascuno di 12 mm di spessore, a contatto tra loro posizionati nella parte alta della tenuta e protetti da due anelli di acciaio e da un ulteriore anello di grafite, anch'esso di 12 mm e protetto da due anelli di acciaio nella parte inferiore.

In fase di realizzazione, in luogo della grafite, si è deciso di utilizzare un polimero plastico per guarnizioni caratterizzato da una elevata stabilità meccanica e dimensionale alle alte temperature (Karlez ® prodotto da Angst+Pfister). Pertanto si è scelto di acquistare una lastra di kalrez, la cui specifica tecnica è riportata in allegato 31, dello spessore di 2.03 mm e lavorare una serie di dischetti, in modo da poter provare diversi spessori (da 2.03 mm a 12.18 mm). Lo spessore totale della tenuta, che deve essere sempre mantenuto, viene garantito dalla sostituzione dei dischi di grafite con dischi di acciaio. In tutto sono stati realizzati 18 dischi di grafite e si prevede di utilizzarne minimo 3, massimo 18; sono stati realizzati anche 15 dischi di acciaio, del tutto uguali al particolare 6 della tavola 16 del

disegno 074-00-01rev3. Si rimanda alla tavola 15 del disegno 074-00-01rev3 per i dettagli sugli anelli di grafite.

La possibilità di allestire tenute con pacchi in karlez di differenti spessori consentirà di effettuare sperimentalmente l'ottimizzazione della stratigrafia della tenuta.

4.10 Modifiche alle connessioni con i sistemi ausiliari

Di seguito si riporta il paragrafo 4.1.8 di [1] con le modifiche effettuate in sede di realizzazione.

Lo schema di flusso, dis. 074-02-00rev3, rappresenta le interconnessioni della sezione di prova con i circuiti ausiliari che ne consentono il funzionamento. In particolare sono visibili:

- il collegamento con il sistema di riempimento
- il collegamento con la linea di scarico per lo svuotamento,
- l'alimentazione con l'acqua di raffreddamento dello scambiatore principale
- l'alimentazione con l'acqua di raffreddamento dello scambiatore EBT
- l'alimentazione elettrica alle barre in prova,
- l'alimentazione elettrica alla candela del pressurizzatore.

Il carico del circuito potrà essere fatto sia riempiendo il pensile "IETI", avviando la sola pompa BP a bassa pressione, raggiungendo la pressione massima di circa 1 bar corrispondente al battente del serbatoio, oppure mediante la pompa a pistoni ad alta pressione ("IMAMI"). In questo caso, agendo sul bypass della pompa stessa, sarà possibile immettere nel circuito acqua a pressione crescente fino al valore di progetto di 172.5 bar. Il superamento della pressione di 172.5 bar determinerà l'apertura della valvola di sicurezza posta sul pressurizzatore.

Lo scarico potrà avvenire sia a caldo sia a freddo, aprendo le linee di scarico.

Il raffreddamento dello scambiatore inserito nel ramo discendente del circuito principale sarà controllato variando il livello nel tubo esterno dello scambiatore coassiale. Allo scopo è prevista una valvola di regolazione, comandata dal segnale proveniente da un trasduttore di pressione differenziale, che misura il livello collassato nel secondario dello scambiatore. L'alimentazione di acqua è derivata dal circuito "IETI-4" ("Booster 2 + PERONI 3"), transitando attraverso l'impianto "IRIS ELICOIDALE".

Per l'alimentazione della portata necessaria è sufficiente attivare la sola pompa "Booster 2".

L'alimentazione elettrica è realizzata in corrente continua con controllo di tensione. Il gruppo convertitore è in grado di erogare 25000 A, con tensioni massime di 160 V, per una potenza di 8000 kW. La potenza assorbita dalle barre sarà di 116 kW complessivi, la linea è quindi dimensionata per un migliaio di Ampère.

La candela scaldante del pressurizzatore ha tensione di alimentazione di 380 Vac/3ph. È prevista un'alimentazione mediante relè statico, la regolazione della potenza erogata è gestita da un regolatore PID.

4.11 Calcoli verifica condizioni operative

Sono stati aggiornati i calcoli di verifica meccanica del circuito alle varie condizioni operative, con il software di calcolo Autopipe Plus V8.i, che permette la verifica meccanica delle tubazioni anche secondo la norma UNI EN 13480:2002, norma armonizzata alla direttiva PED 97/23/CE. I risultati dei

calcoli eseguiti col software sono coerenti con i precedenti risultati [1], ottenuti anche col calcolo manuale e l'applicazione di regole empiriche, dando valore aggiunto alla progettazione del sistema.

La disponibilità di un congruo numero di punti su cui costruire il modello ha consentito di modellare e verificare il circuito nella sua interezza, invece che singoli tratti di linea, a varie condizioni operative, inclusa la prova idraulica, e in combinazioni di carico previste dalla normativa o definite dall'utente (descritte più avanti in questo paragrafo), nonché di definire e verificare tipo e posizioni dei supporti.

È stata fatta l'analisi statica del circuito, con le varie combinazioni di carico previste dalla normativa, e la verifica in condizioni di prova idraulica.

La rappresentazione dell'impianto con Autopipe riproduce fedelmente quella del disegno

074-00-00rev3, tranne per le seguenti parti:

- la tenuta, il cui contributo è stato schematizzato con un peso di 105 kg, dovuto al peso delle flange inferiori non rappresentate, della tenuta interna e delle barre di combustibile, applicato all'estremità inferiore del circuito principale;
- il peso della resistenza del PRZ (15 kg), è stato applicato alla flangia superiore dello stesso;
- lo scambiatore sul circuito principale, rappresentato come un peso di 227 kg, all'altezza della flangia, dovuto all'involucro esterno ed al suo contenuto di acqua, mentre un ulteriore peso di 60 kg, disassato lungo l'asse y (di Autopipe) di 465.5 mm (asse del baricentro) rappresenta il contributo del serbatoio di recupero condensa e del suo circuito;
- sul ramo dell'EBT, a livello della flangia, un peso aggiuntivo di 60 kg rappresenta il contributo dello scambiatore e del suo contenuto.

Nel circuito sono presenti dei raccordi a "TEE" ridotti a tasca: il programma applica per essi un SIF (fattore di intensificazione degli sforzi) di 2.1 (come raccomandato dalle ASME), ma, una volta definito, lo applica per tutti i TEE, e non consente di discriminare tra quelli a tasca e quelli normali che sono saldati di testa. Questo, essendo peggiorativo rispetto alla situazione reale, è conservativo relativamente ai risultati ottenuti.

Il programma consente, attraverso l'introduzione nei dati di input della densità relativa, di considerare il battente idrostatico del fluido contenuto nelle tubazioni. Per semplicità abbiamo considerato che fossero completamente piene di acqua. Le flange, che possono essere scelte come tipo e rating, sono considerate dal programma come puntiformi, pertanto le lunghezze delle tubazioni indicate sono comprensive dell'ingombro delle flange. Il programma ne considera comunque il peso. Anche i supporti sono considerati come puntiformi. Le valvole sono state inserite, sulla base dei dati disponibili, con gli ingombri ed il peso. Si è introdotto anche il coibente, ove presente nel circuito, di cui è stato designato lo spessore ed il materiale, coerentemente con i dati riportati in [1].

In Figura 2 è riportata la rappresentazione dell'impianto, con indicati i "size" dei tubi, le schedule di tubi e flange, nonché la tipologia delle flange e i supporti, anch'essi considerati dal calcolo come puntiformi, e i carichi concentrati applicati.



Figura 2: "size" dei tubi, schedule di tubi e flange, posizione supporti

Le 3 condizioni operative prese in esame per la verifica sono:

Caso 1: condizioni stazionarie di partenza.

Pressione caso 1: 172.5 bar

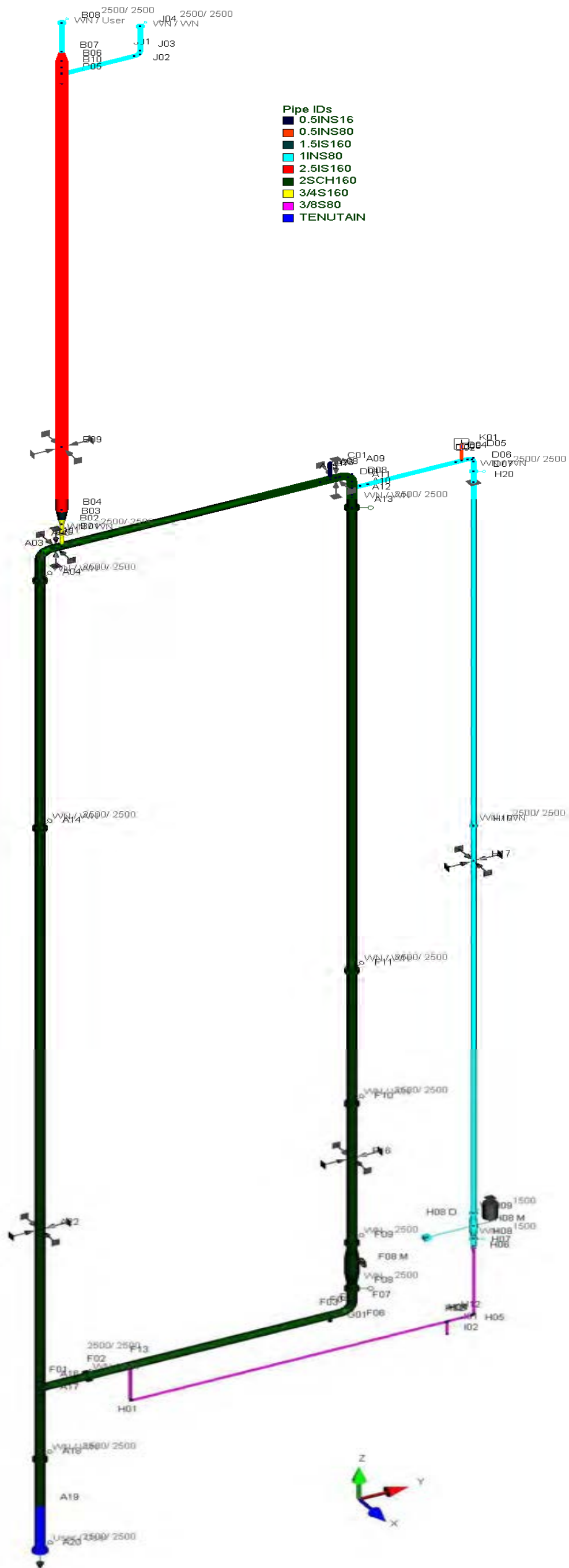
I rami ascendente ed orizzontale superiore sono alla temperatura di uscita core (330°C), il resto del circuito principale è a 292 °C, temperatura dell'acqua nel primario, dopo aver attraversato il GV; l'EBT è freddo (20 °C); le temperature sono visualizzate in Figura 3 con l'indicazione della pressione.

Caso 2: depressurizzazione del sistema ed iniezione EBT

Pressione caso 2: 100 bar

Il circuito principale è come nel caso 1, supponendo che l'acqua non abbia avuto il tempo di portarsi alla temperatura di saturazione corrispondente alla pressione del circuito; nell'EBT a regime entra acqua a 330 °C ed esce a 40°C, grazie al raffreddamento dovuto al flussaggio continuo di acqua a temperatura ambiente nello scambiatore. L'acqua a 40°C viene iniettata nel circuito principale; le temperature sono visualizzate in Figura 4 con l'indicazione della pressione.

Caso 3: condizioni di fine transitorio

Pressione caso 3: 5 bar

Alla fine del transitorio, della durata di ca 5000 s, tutti i circuiti sono alla stessa pressione (5 bar) e temperatura (120 °C), mentre il PRZ è saturo (152 °C). le temperature sono visualizzate in Figura 5 con l'indicazione della pressione.



Figura 3: Caso 1, pressione 172.5 bar



Figura 4: Caso 2, pressione 100 bar

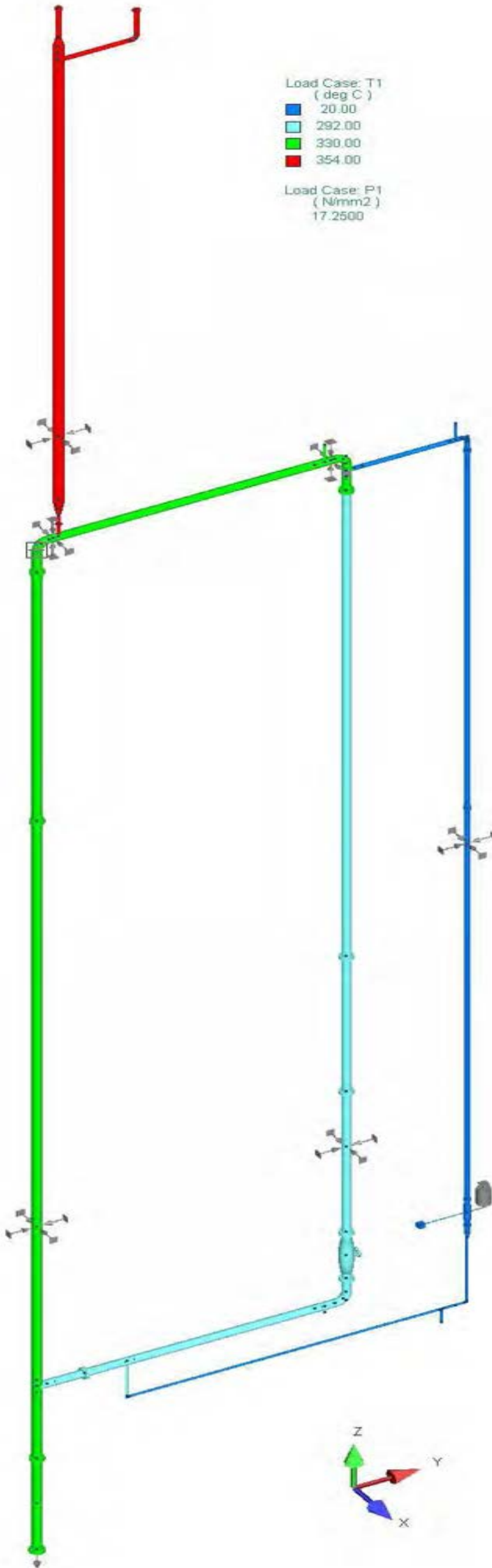

Figura 5: Caso 3, pressione 5 bar

Per i vari casi di carico considerati, si riporta la rappresentazione della verifica delle tensioni ammissibili secondo Von Mises, per le condizioni di carico dovute a battente idrostatico (gravity), pressioni e temperature, nonché della verifica in prova idraulica, alla massima pressione circonferenziale (Hoop stress), ed al creep.

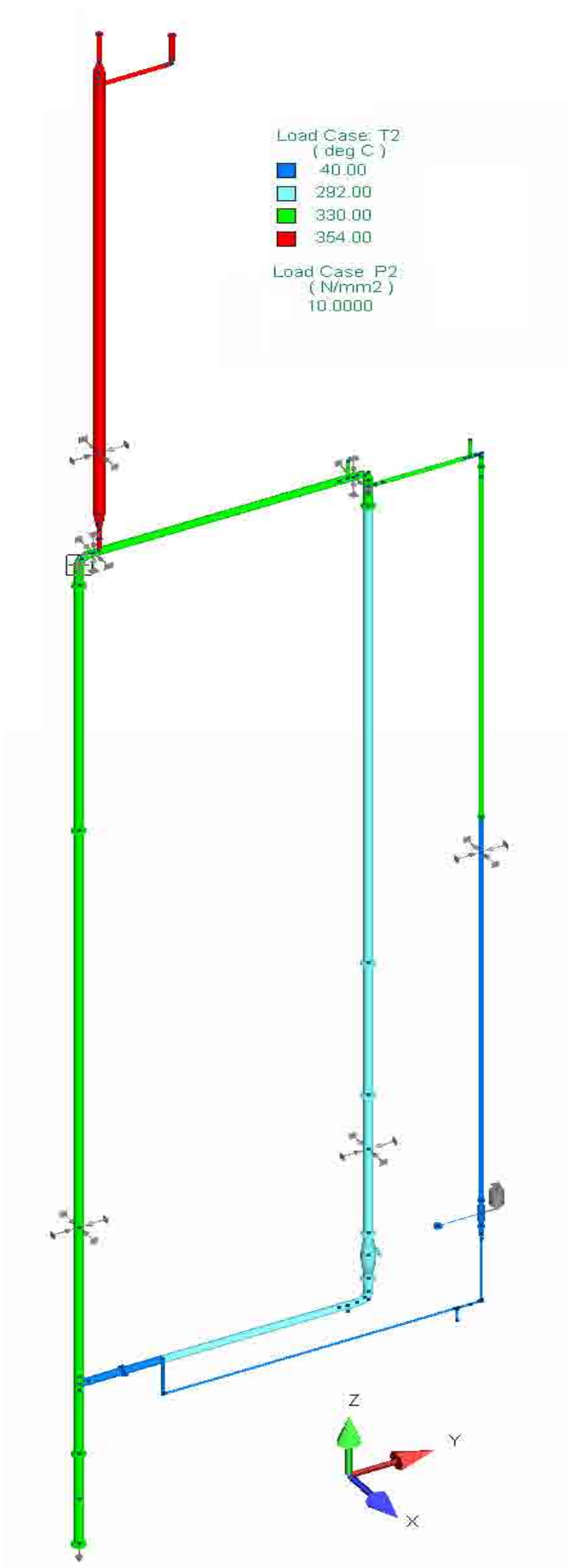
Le verifiche effettuate con Autopipe V8.1 riguardano:

Determinazione delle tensioni massime ammissibili

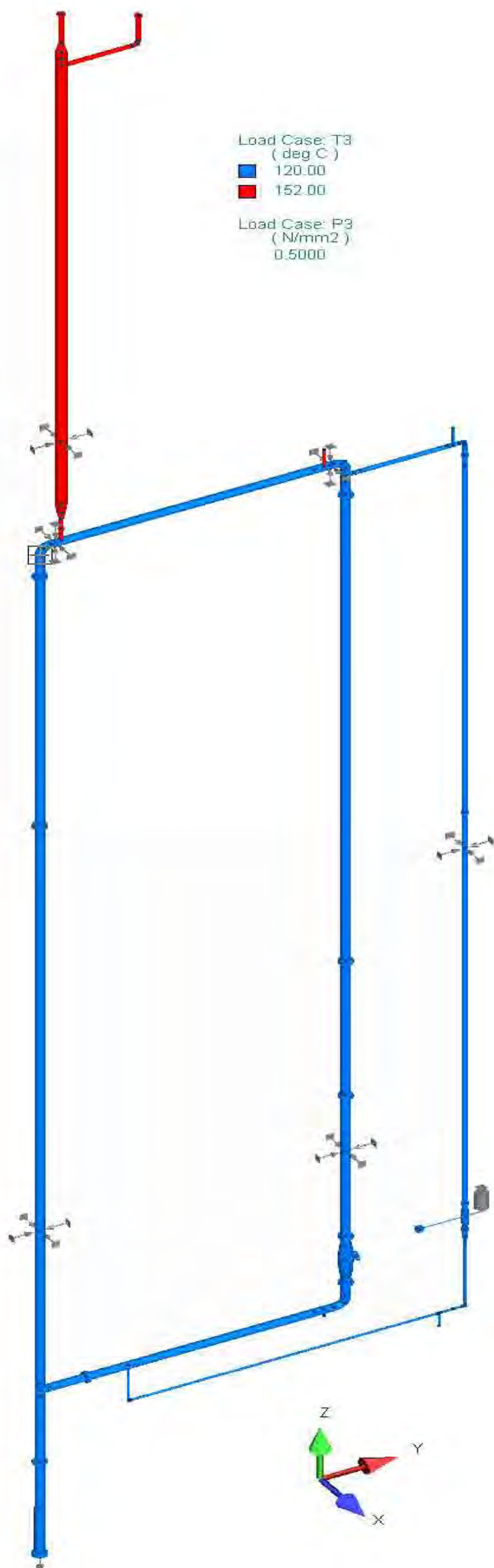
(Formula ricavata da Norma UNI EN 13480-3)

Per acciai austenitici, con allungamento $A > 35\%$, la sollecitazione max ammissibile è data dalla 5.2.2-1 della norma UNI EN 13480-3

$$f = \frac{R_{p1,0t}}{1.5}$$

Dove $R_{p1,0t}$ è il carico unitario di scostamento dalla proporzionalità all'1%, alla temperatura media di parete dichiarata in progetto;

Tensioni dovute ai carichi di pressione, peso proprio del sistema e del suo contenuto, ed eventuali carichi meccanici (SUS)

$$\sigma_1 = \frac{p_c * d_o}{4 * e_n} + \frac{0.75 * i * M_A}{Z} \leq k * f_h$$

La visualizzazione delle tensioni e del punto in cui si registra lo stress massimo è in Figura 6.

Determinazione delle tensioni per il calcolo della flessibilità tenendo conto dei carichi termici (Amb+T_i)

$$\sigma_3 = \frac{i * M_c}{Z} \leq f_a$$

Avendo selezionato una combinazione di calcolo che include il "Maximum range combination", questo caso comprende i risultati del massimo range termico delle combinazioni di carico considerate (nel nostro caso da T₁ a T₃) con il range termico della temperatura ambiente Amb+T_i.

Per brevità viene riportata solo la visualizzazione delle tensioni con carico termico generato dalla distribuzione di temperatura del caso 2 e pressione del caso 1, che è risultata essere la più gravosa, Figura 7.

Prova idraulica (Hydrotest)

La prova viene eseguita a temperatura ambiente, il programma esegue la verifica considerando una pressione di prova pari a 1.43xPS, quindi viene simulata ad una pressione di 246.7 bar.

La tensione calcolata con questo valore di pressione, tenendo conto dei carichi agenti sulla tubazione, non deve superare la tensione massima ammissibile calcolata dalla 5.2.2-1 della norma UNI EN 13480-3. La tensione massima e il punto in cui si registra è rappresentata in Figura 8.

Hoop stress (max. P₁)

L'hoop stress è la tensione circonferenziale che agisce su un elemento cilindrico sottoposto a pressione interna o esterna.

$$\sigma_{hoop} = \frac{p_{max} D_o}{2e_n z} - \frac{p_{max} Y}{z} \leq f$$

dove

Y= coefficiente di hoop stress = 0.5 (default)

z efficienza della saldatura=1 per tubo non saldato

D_o = diametro esterno della tubazione

e_n = spessore ridotto della tubazione= (e_n-c₀-c₁) dove

e_n = spessore nominale della tubazione;

c₀ = tolleranza di corrosione;

c₁ = valore assoluto della tolleranza negativa sullo spessore (dallo standard del materiale o dichiarata dal produttore della tubazione).

La visualizzazione dello hoop stress e del punto in cui si registra la tensione maggiore è in Figura 9.

Creep stress (Creep Rupt)

La formula è ricavata dalla Norma UNI EN 13480-3, è la 5.3.2-1

$$f_{CR} = \frac{S_{RTt}}{SF_{CR}}$$

Nella formula sopra,

S_{RTt} è il valore medio della tensione ammissibile per rottura da creep.

SF_{CR} è il fattore di sicurezza che dipende dal tempo e deve essere in accordo con la Tabella 5.3.2-1 della Norma UNI EN 13480-3

La norma UNI EN 13480:2002 non consente di trascurare le tensioni da creep, ma queste hanno significato, a seconda del tempo di vita dell'impianto, mai da considerarsi inferiore alle 100000 h, ed a partire da temperature superiori a 550°C, ben al di sopra della nostra temperatura di progetto, ed al di sopra del tempo ragionevole di esercizio dell'impianto. La Tabella 4-3 esemplifica quanto detto, dal che deriva l'impossibilità di calcolare la tensione ammissibile; questo è il senso di quanto affermato nella Nota 1 in Figura 10.

Generated datasheet of Seamless tube and pipe - 5R10

Creep strength		Creep-rupture 10 000 h MPa approx.	strength ksi approx.	(ISO-values) 100 000 h MPa approx.	ksi approx.
Temperature °F	°C				
550	1020	195	28.3	115	16.6
575	1065	147	21.3	93	13.5
600	1110	122	17.6	74	10.7
625	1155	100	14.5	58	8.4
650	1200	79	11.5	45	6.5
675	1245	64	9.2	33	4.8
700	1290	48	7.0	23	3.3

Tabella 4-3 - Tensioni da creep AISI 304

Verifica a fatica: Non necessaria perché il numero di cicli previsto è < 1000;

Per le ragioni già spiegate nel documento di progettazione [1], non consideriamo carichi sismici, né dovuti al vento o alla neve, né carichi dinamici o alternati.



Figura 6: Rappresentazione delle tensioni dovute a carichi di pressione, peso proprio del sistema e del suo contenuto, e carichi meccanici (SUS)



Figura 7: Visualizzazione delle tensioni tenendo conto dei carichi termici con distribuzione di temperatura del caso 2 e pressione del caso 1

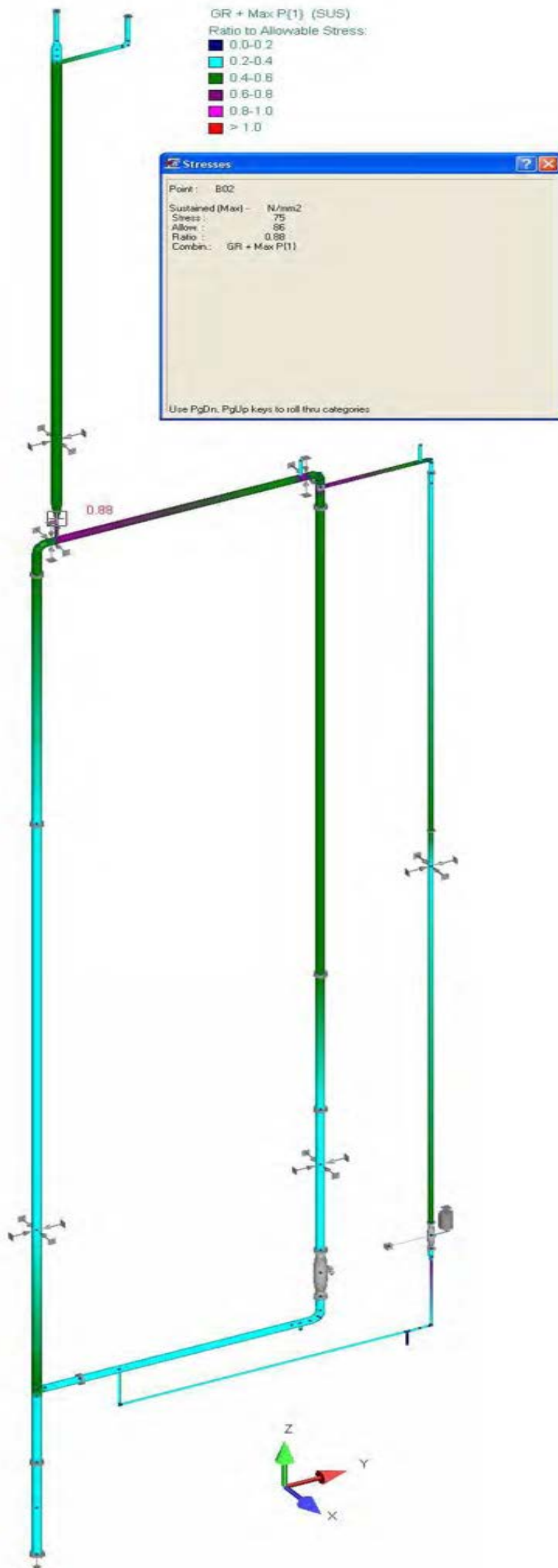

Figura 8: Simulazione di prova idraulica, con pressione pari a 1.43 volte la pressione del caso 1 e acqua a temperatura ambiente

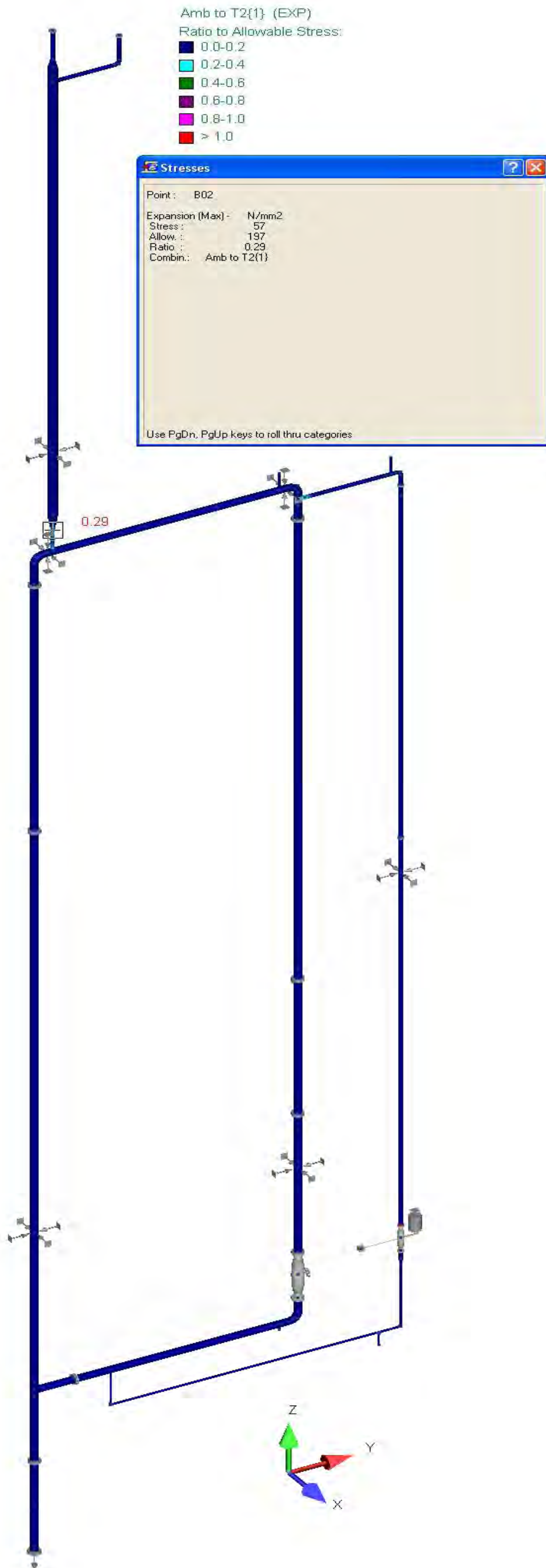

Figura 9: Visualizzazione della tensione circonferenziale

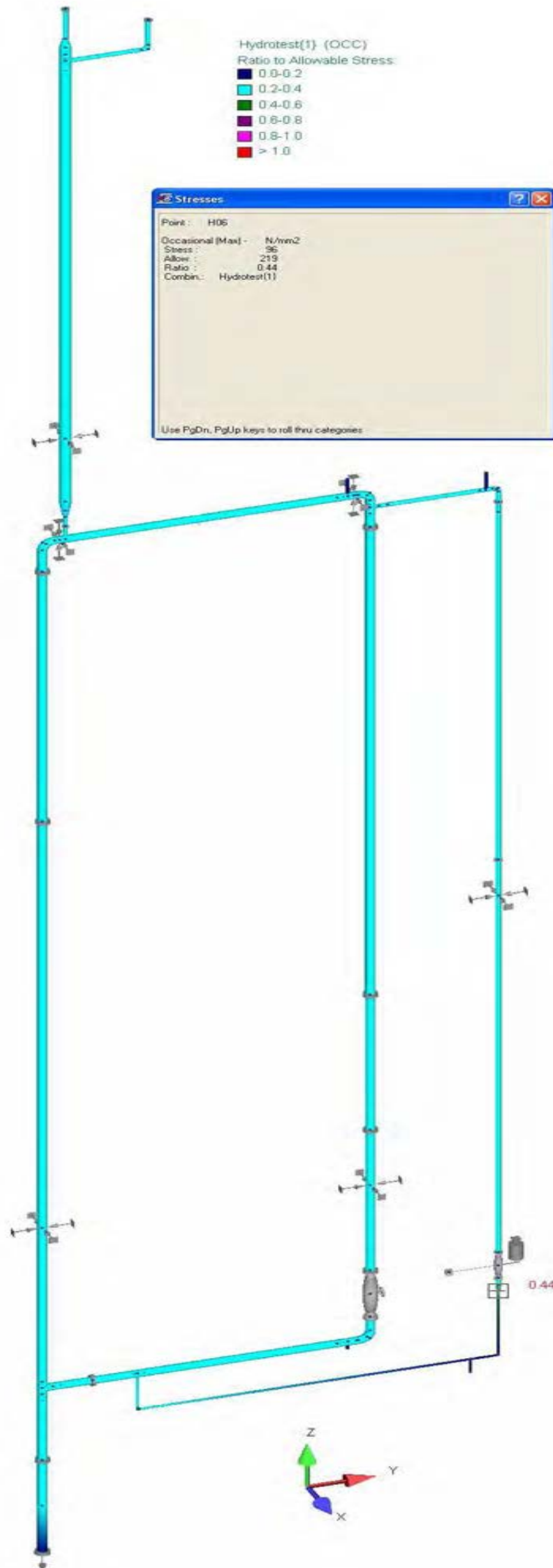

Figura 10: Visualizzazione delle tensioni da creep

Per ogni condizione operativa è presentata la visualizzazione, Figura 11, Figura 12 e Figura 13, degli spostamenti dell'intero circuito nelle condizioni accoppiate GT, cioè l'effetto combinato del peso del sistema e del suo contenuto (G =gravity). con le temperature T dei casi considerati, perché è quello che racchiude informazioni globali sulla deformata del sistema.

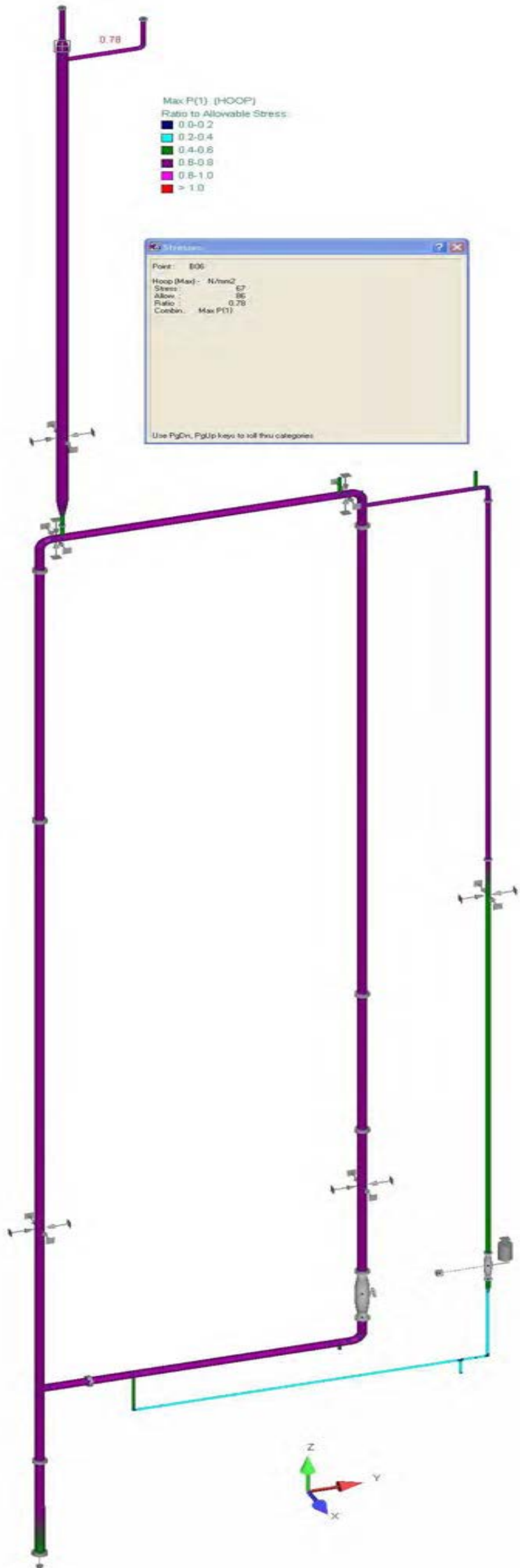
L'entità degli spostamenti nelle figure 11,12 e 13 è amplificata di un fattore 5 per migliorarne la percezione, in realtà gli spostamenti globali sono molto contenuti.

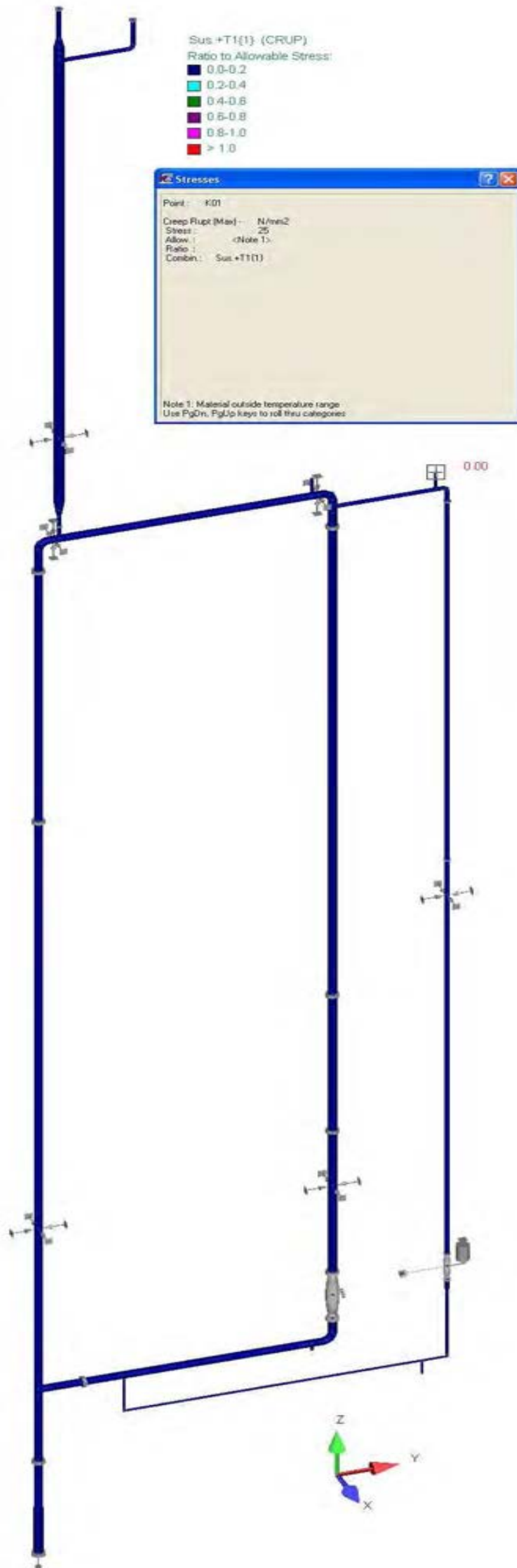

Figura 11: Visualizzazione degli spostamenti del circuito sotto effetto combinato del peso del sistema e del suo contenuto con distribuzione di temperature del caso 1 e pressione del caso 1.



Figura 12: Visualizzazione degli spostamenti del circuito sotto effetto combinato del peso del sistema e del suo contenuto con distribuzione di temperature del caso 2 e pressione del caso 1.

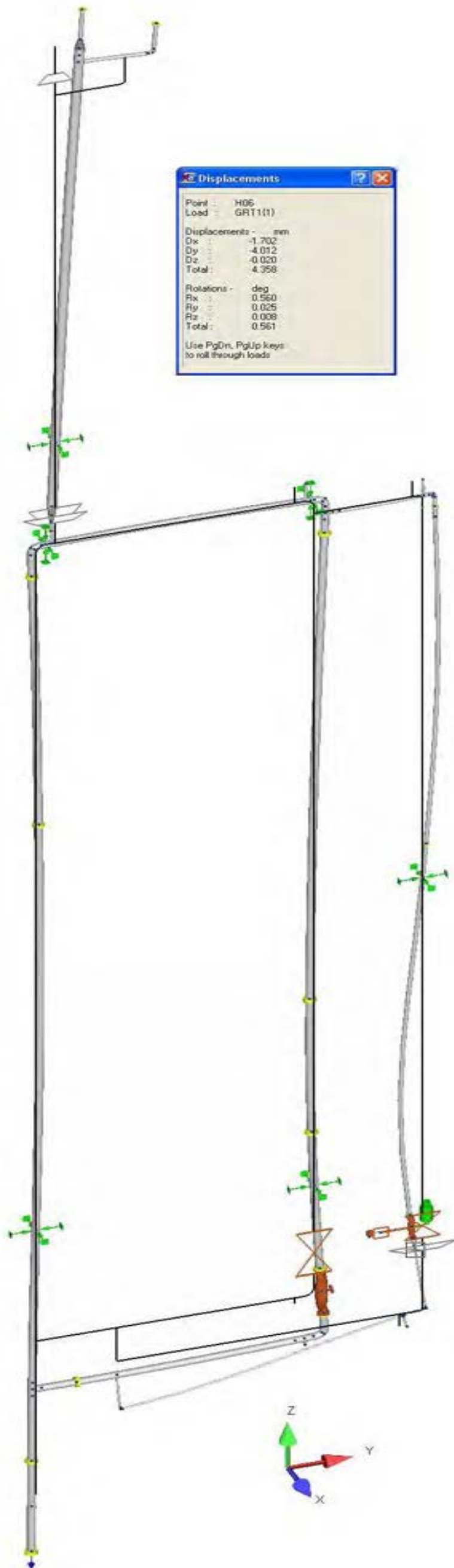

Figura 13: Visualizzazione degli spostamenti del circuito sotto effetto combinato del peso del sistema e del suo contenuto con distribuzione di temperature del caso 3 e pressione del caso 1.

4.12 Modifiche ai supporti

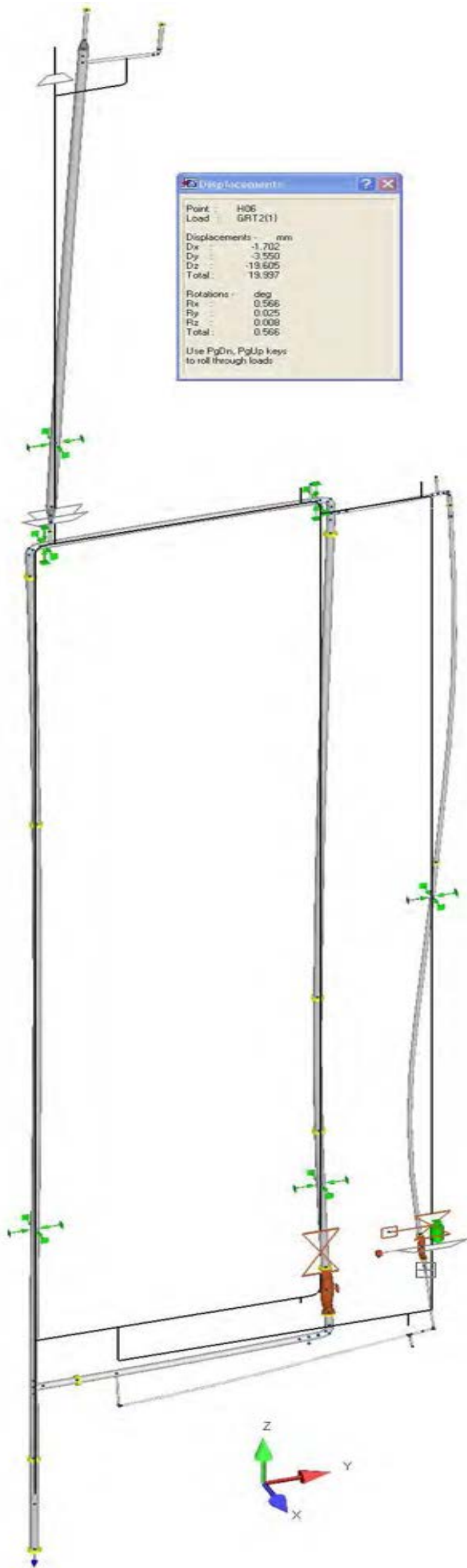
I sostegni relativi alle interfacce tra impianto e struttura portante (disegno 074-00-02rev2) comprendono 3 punti di ancoraggio invece di 2; è leggermente cambiato il punto di attacco, sul ramo principale, ma si ritiene comunque valido il calcolo preesistente, dato che l'attuale, avendo aumentato il numero di ancoraggi, è ancora più conservativo.

Tutto il circuito è sorretto dall'alto tramite 2 travi UPN 120, che sono fissate alle 3 travi IPN 220 preesistenti nella struttura (a livello del pavimento del 9° piano), le quali corrono trasversalmente all'impianto, come evidenziato nel dis. 074-00-02rev2. Il fissaggio delle UPN 120 alle IPN 220 avviene, sulle ali delle IPN 220, tramite 2 piattini per trave, di dimensioni 70x130 sp. 15. Al di sotto di ognuno di questi un blocchetto 50x87 sp.12 agisce da livellante tra trave e piattino. Due bulloni M14x85 per lato fissano questi tre componenti, realizzando il collegamento meccanico tra le travi. Il collegamento delle UPN 120 al circuito avviene in 3 punti. Nel tratto orizzontale superiore del circuito, esternamente ai TEE, da cui si diparte il PRZ da un lato, e la valvola di sfiato del circuito principale dall'altro, ed al di sotto della flangia in corrispondenza all'asse verticale dell'EBT, nei quali si sono considerati concentrati i pesi dell'impianto, si staccano i sostegni, che si collegano alle travi UPN 120 con 2 tiranti M16 di adeguata lunghezza.

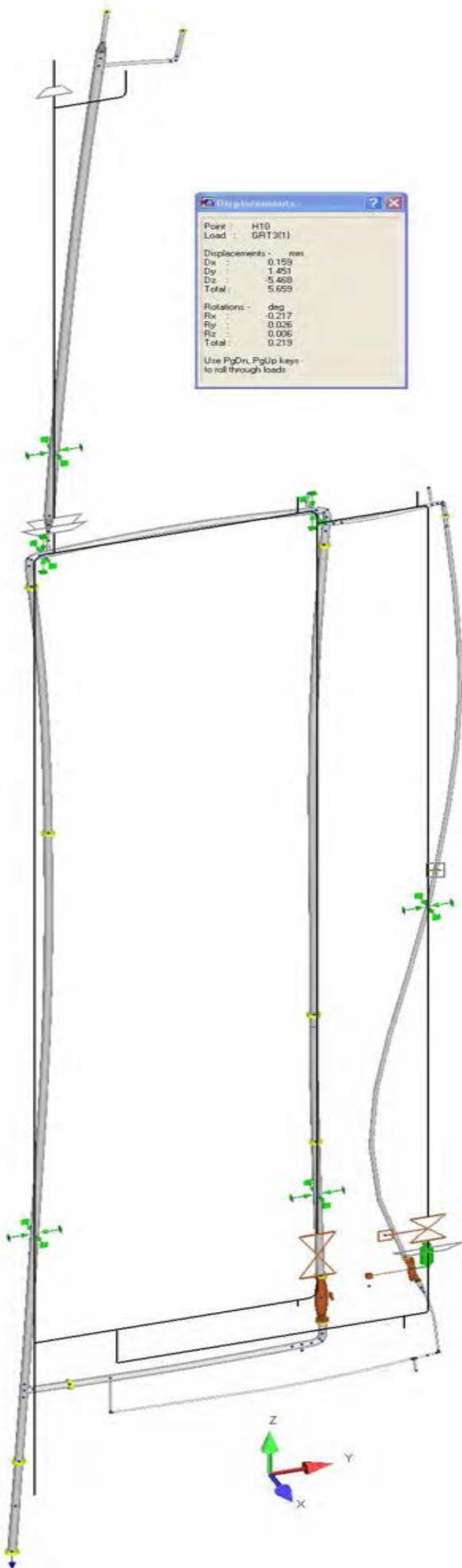
Il calcolo di verifica meccanica del circuito con Autopipe prevede l'effettuazione della scelta dei supporti per il sostegno delle tubazioni. I carichi sui supporti sono nel report dei risultati, allegato 32.

Pertanto la scelta del tipo di vincolo e la sua localizzazione sono il frutto di un compromesso tra le risultanze del calcolo e l'interfaccia tra impianto e struttura.

I supporti, per il circuito principale, hanno la funzione di guide, che consentono quindi la libera dilatazione in senso assiale e sorreggono il peso dell'impianto, mentre il sostegno dell'EBT, serrato al tubo, si può schematizzare nel calcolo come un'ancora flessibile, che blocca il movimento della linea nel solo senso verticale. Un ulteriore sostegno, realizzato con una molla a carico variabile, tarata a 1000 N (cold load), sostiene verticalmente la valvola sull'EBT. Il pressurizzatore e i 3 rami verticali del circuito sono guidati verticalmente, per consentirne la libera dilatazione a seguito del gradiente termico che si verifica durante il funzionamento dell'impianto, mantenendone l'allineamento. Il disegno 074-00-02rev2 fornisce le indicazioni su come sono stati realizzati i supporti e sulla loro locazione.

4.13 Modifiche riguardanti la candela del pressurizzatore

La resistenza del pressurizzatore ha lo scopo di pressurizzare l'impianto. La sua potenza è di 25 kW, come indicato in [1]. La candela è stata realizzata secondo la specifica tecnica e il disegno in allegato 33. L'allegato riporta anche la specifica tecnica "as built" del costruttore. L'elemento scaldante viene energizzato da un sistema elettrico trifase con controllo PWM. È presente una termocoppia inserita nell'elemento posizionata alcuni millimetri al di sopra della parte attiva.

Prima di essere posizionata all'interno del pressurizzatore sono state fatte alcune verifiche:

- misura della resistenza di ciascun elemento, con risultato di circa 16 ohm/elemento
- verifica dell'isolamento di ciascun elemento
- prova di alimentazione a bassa tensione
- verifica della termocoppia.

Tutte le verifiche hanno avuto esito positivo.

4.14 Modifiche all'elenco delle misure

Il paragrafo 10.2 di [1] rimane invariato nei contenuti, mentre la tabella 2 riporta l'elenco aggiornato delle misure dirette e strumenti" e la tabella 3 l'elenco aggiornato delle misure derivate.

Tabella 4-4: elenco misure dirette e strumenti

n	descrizione	Codice misura	Tipo di Strumento	Segnale dello strumento	U. M.	costruttore	modello	tipo di condizionatore	costruttore	modello
1	circuito primario quota inferiore barre	T-1 OP	Termocoppia tipo K	mvTC non compensata	mV	TERMOTECH	(*)			
2	circuito primario quota mediana barre	T-2	Termocoppia tipo K	mvTC non compensata	mV	TERMOTECH	(*)			
3	circuito primario quota superiore barre	T-3	Termocoppia tipo K	mvTC non compensata	mV	TERMOTECH	(*)			
4	Circuito primario discendente quota superiore	T-4	Termocoppia tipo K	mvTC non compensata	mV	TERMOTECH	(*)			
5	uscita scambiatore lato primario	T-5	Termocoppia tipo K	mvTC non compensata	mV	TERMOTECH	(*)			
6	circuito primario lato discendente zona bassa	T-6	Termocoppia tipo K	mvTC non compensata	mV	TERMOTECH	(*)			
7	circuito primario discendente quota inferiore	T-7 OP	Termocoppia tipo K	mvTC non compensata	mV	TERMOTECH	(*)			
8	circuito primario iniezione linea di ritorno	T-8	Termocoppia tipo K	mvTC non compensata	mV	TERMOTECH	(*)			
9	quota inferiore pressurizzatore	T-30	Termocoppia tipo K	mvTC non compensata	mV	TERMOTECH	(*)			
10	quota mediana pressurizzatore	T-31 OP	Termocoppia tipo K	mvTC non compensata	mV	TERMOTECH	(*)			
11	quota superiore pressurizzatore	T-32	Termocoppia tipo K	mvTC non compensata	mV	TERMOTECH	(*)			
12	linea iniezione EBT quota superiore	T-40 OP	Termocoppia tipo K	mvTC non compensata	mV	TERMOTECH	(*)			
13	uscita linea iniezione scambiatore EBT	T-41 OP	Termocoppia tipo K	mvTC non compensata	mV	TERMOTECH	(*)			
14	linea iniezione EBT quota inferiore	T-42 OP	Termocoppia tipo K	mvTC non compensata	mV	TERMOTECH	(*)			
15	scambiatore circuito primario lato second. quota sup.	T-50	Termocoppia tipo K	mvTC non compensata	mV	TERMOTECH	(*)			
16	scambiatore EBT lato secondario quota mediana	T-60 OP	Termocoppia tipo K	mvTC non compensata	mV	TERMOTECH	(*)			
17	temperatura di parete barra 1 inferiore	TW-101a	Termocoppia tipo K inglobata	mvTC non compensata	mV	n.d.	(***)			
18	temperatura di parete barra 1 inferiore intermedia	TW-101b	Termocoppia tipo K inglobata	mvTC non compensata	mV	n.d.	(***)			
19	temperatura di parete barra 1 superiore intermedia	TW-101c	Termocoppia tipo K inglobata	mvTC non compensata	mV	n.d.	(***)			
20	temperatura di parete barra 1 superiore	TW-101d	Termocoppia tipo K inglobata	mvTC non compensata	mV	n.d.	(***)			
21	temperatura di parete barra 2 inferiore	TW-102a	Termocoppia tipo K inglobata	mvTC non compensata	mV	n.d.	(***)			
22	temperatura di parete barra 2 inferiore intermedia	TW-102b	Termocoppia tipo K inglobata	mvTC non compensata	mV	n.d.	(***)			
23	temperatura di parete barra 2 superiore intermedia	TW-102c	Termocoppia tipo K inglobata	mvTC non compensata	mV	n.d.	(***)	TC/Volt	PRELECTRONICS	4116
24	temperatura di parete barra 2 superiore	TW-102d	Termocoppia tipo K inglobata	mvTC non compensata	mV	n.d.	(***)	TC/Volt	PRELECTRONICS	4116
25	temperatura di parete barra 3 inferiore	TW-103 a	Termocoppia tipo K inglobata	mvTC non compensata	mV	n.d.	(***)	TC/Volt	PRELECTRONICS	4116
26	temperatura di parete barra 3 inferiore intermedia	TW-103b	Termocoppia tipo K inglobata	mvTC non compensata	mV	n.d.	(***)	TC/Volt	PRELECTRONICS	4116
27	temperatura di parete barra 3 superiore intermedia	TW-103c	Termocoppia tipo K inglobata	mvTC non compensata	mV	n.d.	(***)	TC/Volt	PRELECTRONICS	4116
28	temperatura di parete barra 3 superiore	TW-103d	Termocoppia tipo K inglobata	mvTC non compensata	mV	n.d.	(***)	TC/Volt	PRELECTRONICS	4116
29	temperatura di parete barra 4 inferiore	TW-104 a	Termocoppia tipo K inglobata	mvTC non compensata	mV	n.d.	(***)	TC/Volt	PRELECTRONICS	4116
30	temperatura di parete barra 4 inferiore intermedia	TW-104b	Termocoppia tipo K inglobata	mvTC non compensata	mV	n.d.	(***)	TC/Volt	PRELECTRONICS	4116
31	temperatura di parete barra 4 superiore intermedia	TW-104c	Termocoppia tipo K inglobata	mvTC non compensata	mV	n.d.	(***)	TC/Volt	PRELECTRONICS	4116
32	temperatura di parete barra 4 superiore	TW-104d	Termocoppia tipo K inglobata	mvTC non compensata	mV	n.d.	(***)	TC/Volt	PRELECTRONICS	4116
33	temperatura di parete flangia tenuta posizione A	TW200A	Termocoppia tipo K di parete	mvTC non compensata	mV	TERMOTECH	(**)			
34	temperatura di parete flangia tenuta posizione B	TW200B	Termocoppia tipo K di parete	mvTC non compensata	mV	TERMOTECH	(**)			
35	temperatura di parete flangia tenuta posizione C	TW200C	Termocoppia tipo K di parete	mvTC non compensata	mV	TERMOTECH	(**)			

n	descrizione	Codice misura	Tipo di Strumento	Segnale dello strumento	U. M.	costruttore	modello	tipo di condizionatore	costruttore	modello
36	temperatura di parete flangia tenuta posizione D	TW200D	Termocoppia tipo K di parete	mvTC non compensata	mV	TERMOTEC	(**)			
37	Temperature ambiente	TROOM	Termocoppia tipo K	mvTC non compensata	mV	TERMOTEC	(*)			
38	Temperatura riscaldatore elettrico pressurizzatore	T-HEAT	Termocoppia tipo K inglobata							
39	pressione ingresso canale	P1	Trasmittitore pressione relativa	analogico	mA	HONEYWELL	STD-170			
40	pressione pressurizzatore	P30	Trasmittitore pressione relativa	analogico	mA	E + H	Cerabar S			
41	pressione differenziale barre	DP-1	Trasmittitore pressione diff.	analogico	mA	E + H	Deltabar S			
42	pressione differenziale barre tratto superiore	DP-2 OP	Trasmittitore pressione diff.	analogico	mA	n.d.	n.d.			
43	pressione differenziale canale di potenza & ramo caldo	DP-3	Trasmittitore pressione diff.	analogico	mA	E + H	Deltabar S			
44	pressione differenziale ramo caldo orizzontale	DP-4	Trasmittitore pressione diff.	analogico	mA	HONEYWELL	STD-120			
45	pressione differenziale scambiatore principale lato prim.	DP-5	Trasmittitore pressione diff.	analogico	mA	E + H	Deltabar S			
46	pressione differenziale ramo freddo verticale	DP-6	Trasmittitore pressione diff.	analogico	mA	E + H	Deltabar S			
47	pressione differenziale ramo freddo orizzontale + valvola	DP-7	Trasmittitore pressione diff.	analogico	mA	HONEYWELL	STD-120			
48	Pressione diff. ramo freddo verticale superiore (venturimetro)	DP-8 OP	Trasmittitore pressione diff.	analogico	mA	n.d.	n.d.			
49	Pressione differenziale ramo freddo verticale inferiore	DP-9 OP	Trasmittitore pressione diff.	analogico	mA	n.d.	n.d.			
50	pressione differenziale pressurizz. stretto range lato inf.	DP-30	Trasmittitore pressione diff.	analogico	mA	HONEYWELL	STD-120			
51	pressione differenziale pressurizzatore largo range	DP-31	Trasmittitore pressione diff.	analogico	mA	E + H	Deltabar S			
52	pressione differenziale ramo caldo orizzontale - altezza intermedia prz	DP-32	Trasmittitore pressione diff.	analogico	mA	HONEYWELL	STD-120			
53	pressione differenziale venturimetro	DP-20	Trasmittitore pressione diff.	analogico	mA	HONEYWELL	STD-120			
54	pressione differenziale linea iniezione verticale	DP-40	Trasmittitore pressione diff.	analogico	mA	E + H	Deltabar S			
55	pressione differenziale linea iniezione orizzontale & valvola	DP-41	Trasmittitore pressione diff.	analogico	mA	HONEYWELL	STD-120			
56	pressione differenziale scambiatore princip. lato second.	DP-50	Trasmittitore pressione diff.	analogico	mA	E + H	Deltabar S			
57	pressione differenziale vaschetta di raccolta	DP-51	Trasmittitore pressione diff.	analogico	mA	HONEYWELL	STD-120			
58	corrente elettrica canale potenza	I100	Shunt	analogico	V	IME	1000A	mV/Volt	WEIDMUELLER	WAS PRO DC/DC
58	corrente elettrica su singola barra (barra x - da definire)	I10x	Shunt	analogico	V	IME	300A	mV/Volt	WEIDMUELLER	WAS PRO DC/DC
60	tensione elettrica canale potenza	V100	Diretto	analogico	V	n.a.	n.a.	mV/Volt	WEIDMUELLER	WAS PRO DC/DC
61	tensione elettrica canale potenza su struttura metallica	V101	Diretto	analogico	V	n.a.	n.a.	mV/Volt	WEIDMUELLER	WAS PRO DC/DC
62	potenza elettrica candela pressurizzatore	W30	Input tipo SSR	analogico	Contatto	SIEMENS	n.a.			
63	fine corsa valvola ON/OFF posizione aperta	Z400	Fine corsa	analogico	Contatto	TELEMECANIQUE	n.a.			
64	fine corsa valvola ON/OFF posizione chiusa	Z40C	Fine corsa	analogico	Contatto	TELEMECANIQUE	n.a.			

(*) termocoppia K, ANSI SPECIAL, lunghezza 150mm, diametro 1.5 mm, cavo 1 m, connettore mignon maschio

(**) termocoppia K, ANSI SPECIAL, piastrina saldata, lunghezza 150mm, diametro 1.0 mm, cavo 1m, connettore mignon maschio

(***) termocoppia inserita nella barra di potenza

OP Strumento opzionale: da installare in base a successive valutazioni sperimentali

Tabella 4-5: elenco misure derivate

n	descrizione	codice misura	misura primaria
1	livello pressurizzatore	L_30	DP-30
2	caduta di pressione barre circuito primario	DP_100	DP-1, DP-3
3	livello scambiatore	L_50	DP-51
4	potenza termica scambiatore	W_50	T-4, T-5, DP-50
5	potenza barra (totale)	W_100	I-100, V-100
6	potenza barra x (singola)	W_10x	I-10 (x), V100
7	livello linea EBT	L_40	DP-40, DP-41
8	portata di ricircolo	F_20	DP-20
9	resistenza elettrica barre	R_100	I-100, V-100

4.15 Modifiche alle misure di deformazione

Le misure di deformazione, indicate in [1] nel paragrafo 10.3.1, non sono più previste.

4.16 Loop di regolazione

Il paragrafo 10.4 di [1], relativo ai loop di regolazione, viene riportato integralmente di seguito, in quanto sono state effettuate alcune modifiche, legate alle scelte costruttive e ai sistemi ausiliari disponibili.

L'impianto dispone dei seguenti sistemi di regolazione, indicati nel dis. 074-02-00rev3:

- PIC-030 pressione del circuito;
- LIC-030 livello liquido nel pressurizzatore;
- JIC-050 potenza termica allo scambiatore.
- FIC-040 isolamento sistema iniezione di emergenza (valvola ON/OFF);
- WIC-100 potenza elettrica al canale

I regolatori di processo utilizzati in alcuni loop sono di tipo programmabile, dotati di interfaccia di comunicazione e sono cablati su bus standard attraverso il quale comunicano con il software di controllo in esecuzione su un personal computer. Il loro utilizzo permette di eseguire azioni sia in modalità manuale sia automatica.

4.16.1 PIC-030 Pressione del circuito

La pressione è regolata attraverso il pressurizzatore, componente collegato al circuito principale attraverso una linea di disaccoppiamento idraulico. Nel pressurizzatore è inserita una candela scaldante che provvede a mandare in ebollizione l'acqua permettendo la formazione di un duomo di vapore.

L'energia necessaria per raggiungere e mantenere la pressione di esercizio sarà erogata in modalità PWM da un sistema costituito da un attuatore statico di potenza (SSR) e da un regolatore di processo a singola azione con uscita per SSR. La variabile di processo di questo loop di regolazione è costituita dal segnale dello strumento P30.

4.16.2 LIC-030 Livello liquido nel pressurizzatore

Per mantenere le condizioni di pressione e temperatura di esercizio deve essere soddisfatto l'equilibrio tra le fasi liquido e vapore dell'acqua contenuta nel pressurizzatore e compensata la variazione di volume del circuito principale. Il livello di acqua nel pressurizzatore si stabilizza in due differenti condizioni:

- monofase liquida sottoraffreddata durante il riempimento e la prima fase di riscaldamento;
- saturo liquido con la formazione di vapore saturo che viene parzialmente spurgato durante l'andata a regime.

La misura di livello, variabile controllata del sistema, è calcolata in entrambe le condizioni per permettere la corretta valutazione della condizione operativa e per eseguire le azioni di

riempimento o di svuotamento. Il sistema di regolazione, costituito da un regolatore PID a doppia azione, agisce sulla valvola di by-pass della pompa di alimento primaria ad alta pressione.

La variabile di processo di questo loop di regolazione è costituita dal segnale dello strumento DP30. Durante l'esercizio questo loop potrà essere mantenuto disattivato, previo isolamento del circuito principale dalla mandata della pompa.

4.16.3 JIC-050 Potenza termica allo scambiatore

Il mantenimento delle condizioni nominali di temperatura all'ingresso del canale è realizzato mediante uno scambiatore di calore acqua/acqua, il cui primario è rappresentato da una sezione del tratto verticale discendente del circuito principale, mentre il secondario è costituito da una vasca, concentrica al tubo primario, contenente acqua satura alla pressione ambiente.

Il volume di scambio viene regolato mediante l'iniezione di acqua fredda dalla linea di riempimento a bassa pressione, tramite un regolatore PID a singola azione con uscita proporzionale che agisce sulla valvola di mandata della pompa al fine di mantenere il livello al valore necessario al corretto scambio termico. La variabile di processo del loop JIC-050 è il valore fornito dallo strumento T5.

4.16.4 FIC-040 Isolamento sistema iniezione di emergenza

La simulazione del funzionamento dell'impianto SPES-3 prevede l'iniezione di un volume noto di acqua fredda. L'iniezione viene realizzata aprendo, in base ad un comando esterno (azione manuale o programmata) una valvola ON/OFF e chiudendola una volta fluita la massa di liquido prestabilita.

La variazione di livello e/o temperatura, misurate mediante gli strumenti DP40, DP41 e T41, comanda la chiusura automatica della valvola. Il sistema di controllo è realizzato con una uscita digitale del Controllore Logico Programmabile (PLC).

4.16.5 WIC-100 Potenza elettrica al canale

L'erogazione di potenza elettrica alle barre del canale verrà realizzata sia in modalità manuale, sia in modalità automatica con "generazione automatica di transistori di potenza", utilizzando una sezione del generatore di corrente continua TAMINI.

Questo sistema è costituito da un trasformatore con secondario esafase e da una serie di diodi raddrizzatori controllati (SCR). Gli SCR vengono eccitati a parzializzazione di fase.

La corrente in uscita è la sommatoria vettoriale delle correnti raddrizzate. Il circuito elettronico di eccitazione viene pilotato con un segnale normalizzato in corrente (4÷20mA), generato dal regolatore di processo PID adibito al controllo della sezione di SCR in uso. Il regolatore è a singola azione ed è pilotato direttamente dal programma di gestione impianto.

4.17 Parametri di controllo

Il paragrafo 10.5 di [1], relativo ai parametri di controllo, viene riportato integralmente di seguito, in quanto sono state modificate le posizioni e i codici di alcuni strumenti di misura.

Per garantire il corretto funzionamento delle macchine e dell'impianto sono previste azioni di intervento automatico al manifestarsi di una condizione anomala o di un allarme. I parametri di impianto che vengono controllati sono i seguenti:

- minima pressione di impianto;
- massima pressione di impianto;
- massima pressione nel pressurizzatore;
- massima temperatura delle barre scaldanti;
- massima temperatura di uscita canale;
- massima temperatura nel pressurizzatore;
- minimo livello liquido nel pressurizzatore;
- minimo livello scambiatore lato secondario;
- massima corrente elettrica al canale di potenza;
- massimo potenziale elettrico al canale di potenza;
- potenziale elettrico canale di potenza e struttura impianto;
- flussaggio scambiatore linea di iniezione EBT;
- watchdog alimentazione elettrica strumenti;
- watchdog SAED;
- watchdog PLC;
- watchdog regolatori di processo.

Il sistema di controllo dell'impianto è realizzato utilizzando un PLC dotato di interfaccia di comunicazione e cablato su bus standard attraverso il quale comunica con il software di controllo in esecuzione su un personal computer. I valori di set point per tutte le grandezze controllate saranno definiti durante le fasi preliminari di collaudo e messa a punto dell'impianto (shake down tests).

I segnali provenienti dalla strumentazione di controllo sono cablati agli ingressi del PLC. Gli attuatori discreti (ON/OFF) sono pilotati dai segnali di uscita del PLC: dove necessario, per motivi

di elevato potenziale elettrico o di forti correnti di eccitazione alle bobine degli attuatori sono inseriti dei relè elettromeccanici di interfaccia.

4.17.1 Minima pressione di impianto

Per evitare crisi termiche durante il warm-up di regimazione viene controllata la condizione di minima pressione di impianto. Questa condizione viene rilevata dal programma di gestione impianto che confronta la misura P1 con il valore di soglia fissato a 20 bar e genera un segnale di inibizione alla erogazione di potenza elettrica che viene inviato al PLC attraverso la comunicazione digitale.

4.17.2 Massima pressione di impianto

La massima pressione di impianto viene rilevata mediante un pressostato con contatto normalmente chiuso. Al raggiungimento della pressione di soglia i contatti si aprono. Il pressostato è idraulicamente collegato alla presa manometrica M3.

4.17.3 Massima pressione nel pressurizzatore

La massima pressione all'interno del pressurizzatore viene rilevata mediante un pressostato con contatto normalmente chiuso. Al raggiungimento della pressione di soglia i contatti si aprono. Il pressostato è collegato alla presa manometrica M32.

4.17.4 Massima temperatura delle barre scaldanti

Ogni barra è dotata di quattro termocoppie immerse nel materiale isolante. Ogni segnale viene derivato ad un dispositivo di condizionamento del segnale dotato di un contatto, che si chiude al raggiungimento del valore di soglia prefissato. Il valore di temperatura a cui fissare questo intervento è superiore alla massima temperatura di uscita canale prevista.

4.17.5 Massima temperatura di uscita canale

Alla misura di temperatura T3, uscita del canale di potenza, viene associato il valore massimo oltre il quale il circuito potrebbe subire danni. Il programma di gestione impianto elabora la misura, la confronta con il valore di soglia prestabilito e genera un segnale di allarme che viene inviato al PLC attraverso la comunicazione digitale.

Alla ricezione di questa informazione il PLC genera la azione di interruzione della potenza elettrica al canale.

Il valore di temperatura a cui fissare questo intervento è inferiore alla massima temperatura raggiungibile dalle barre scaldanti del canale.

4.17.6 *Massima temperatura nel pressurizzatore*

Alla misura di temperatura T30 del pressurizzatore viene associato il valore massimo oltre il quale il componente potrebbe subire danni.

Il programma di gestione impianto elabora la misura, la confronta con il valore di soglia prestabilito e genera un segnale di allarme che viene inviato al PLC attraverso la comunicazione digitale. Alla ricezione di questa informazione il PLC genera le azioni di interruzione della potenza elettrica alla candela del pressurizzatore e al canale.

Il riscaldatore elettrico inserito all'interno del pressurizzatore è dotato di una propria termocoppia. Il segnale di questa termocoppia è collegato ad un dispositivo di condizionamento del segnale ad alto isolamento elettrico dotato di un contatto di allarme, che si chiude al raggiungimento del valore di soglia.

4.17.7 *Livello liquido nel pressurizzatore*

Alla misura del livello di liquido nel pressurizzatore sono associati i valori minimo e massimo oltre i quali il circuito, o parte dei suoi componenti, potrebbe subire danni se venisse protratta l'energizzazione alla candela elettrica. Il programma di gestione impianto elabora la misura di livello di liquido nel pressurizzatore (L-030), la confronta con i valori di soglia prestabiliti e, in funzione delle condizioni operative, genera un segnale di inibizione che viene inviato al PLC attraverso la comunicazione digitale. Alla ricezione di questa informazione il PLC genera la azione di interruzione della potenza elettrica alla candela del pressurizzatore.

4.17.8 *Minimo livello liquido scambiatore lato secondario*

Alla misura livello di liquido L-050 del serbatoio dello scambiatore viene associato il valore minimo oltre il quale il circuito potrebbe subire danni. Il programma di gestione impianto elabora la misura, la confronta con il valore di soglia prestabilito e genera un segnale di allarme che viene inviato al PLC attraverso la comunicazione digitale. Alla ricezione di questa informazione il PLC genera le azioni di interruzione della potenza elettrica alla candela del pressurizzatore e al canale.

4.17.9 *Massima corrente elettrica al canale di potenza*

Alla misura di corrente elettrica totale viene associato il valore massimo di corrente nominale a cui possono lavorare le barre scaldanti. Il programma di gestione impianto elabora la misura, la confronta con il valore di soglia prestabilito e genera un segnale di allarme che viene inviato al PLC attraverso la comunicazione digitale. Alla ricezione di questa informazione il PLC genera le azioni di interruzione della potenza elettrica alla candela del pressurizzatore e al canale.

4.17.10 *Massima corrente elettrica alla singola barra*

Alla misura di corrente elettrica di una singola barra viene associato il valore massimo di corrente nominale a cui possono lavorare le barre scaldanti. Il programma di gestione impianto elabora la misura, la confronta con il valore di soglia prestabilito e genera un segnale di allarme che viene inviato al PLC attraverso la comunicazione digitale. Alla ricezione di questa informazione il PLC

genera le azioni di interruzione della potenza elettrica alla candela del pressurizzatore e al canale.

4.17.11 Massimo potenziale elettrico al canale di potenza

Alla misura di potenziale elettrico viene associato il valore massimo a cui possono lavorare le barre scaldanti. Il programma di gestione impianto elabora la misura, la confronta con il valore di soglia prestabilito e genera un segnale di allarme che viene inviato al PLC attraverso la comunicazione digitale. Alla ricezione di questa informazione il PLC genera le azioni di interruzione della potenza elettrica alla candela del pressurizzatore e al canale.

4.17.12 Minimo potenziale elettrico tra canale di potenza e struttura impianto

Alla misura di potenziale elettrico tra la linea di alimentazione alle barre del canale e la struttura viene associato un valore minimo, al di sotto del quale è possibile la presenza di uno scarso isolamento elettrico. Il programma di gestione impianto elabora la misura, la confronta con il valore di soglia prestabilito e genera un segnale di allarme che viene inviato al PLC attraverso la comunicazione digitale. Alla ricezione di questa informazione il PLC genera le azioni di interruzione della potenza elettrica alla candela del pressurizzatore e al canale.

4.17.13 Flussaggio scambiatore linea di iniezione EBT

Lo scambiatore della linea di iniezione EBT viene mantenuto costantemente flussato, sul lato secondario, durante l'esercizio dell'impianto, per garantire che la riserva di acqua da iniettare sia alla temperatura ambiente o appena superiore. Sulla linea di flussaggio viene inserito un flussostato a doppio contatto. Ogni contatto è collegato ad un ingresso del PLC. Le azioni in conseguenza di una condizione di allarme determinata dall'indicazione di mancato flussaggio, verranno gestite in funzione delle esigenze di esercizio impianto e definite al termine del periodo di collaudo.

4.17.14 Watchdog alimentazione elettrica strumenti

Gli alimentatori degli strumenti di misura e di processo sono dotati di un contatto elettrico chiuso durante il funzionamento in condizioni regolari. In caso di sovraccarico questo contatto si apre. Alla ricezione di questa informazione il PLC genera le azioni di interruzione della potenza elettrica alla candela del pressurizzatore e al canale e contemporaneamente ferma la pompa di alimentazione primaria.

4.17.15 Watchdog SAED

L'esercizio delle attività di impianto devono essere costantemente e correttamente monitorate. Una anomalia del SAED deve forzare un intervento per mettere in sicurezza l'impianto e le persone. Si utilizzano due contatti di una scheda digitale del SAED, configurati in anticoincidenza ed un terzo contatto digitale gestito come oscillatore astabile. Questo segnale viene rilevato dal PLC che rileva periodicamente il cambio di stato logico e interviene in caso di mancata commutazione.

Il programma di gestione impianto genera un segnale astabile che viene inviato al PLC attraverso la comunicazione digitale. Il programma in funzione nel PLC interpreta il segnale inviato dal SAED, ne verifica la congruenza col segnale di riferimento impostato al suo interno e, nel caso venga a mancare la coerenza tra i due, genera le azioni di interruzione della potenza elettrica alla candela del pressurizzatore e al canale.

4.17.16 Watchdog PLC

Il PLC è configurato in modo che una condizione di anomalia apra tutti i contatti di uscita e provochi la fermata immediata dell'impianto. Il riavvio dello stesso è condizionato ad un riconoscimento della condizione di allarme e può avvenire esclusivamente in modalità manuale (da parte di un operatore che provvede al ripristino).

4.17.17 Watchdog regolatori di processo

Ogni regolatore di processo viene continuamente interrogato mediante la comunicazione sul bus. Il software di acquisizione verifica che le risposte da ogni dispositivo arrivino correttamente, entro un periodo di tempo prestabilito.

Qualora si manifestasse un ritardo, viene segnalata una condizione di errore. Al manifestarsi di questa condizione di errore viene generato un segnale ed inviato al PLC attraverso la comunicazione digitale.

Alla ricezione di questa informazione il PLC interrompe l'alimentazione elettrica agli attuatori direttamente controllati dal regolatore in avaria.

I regolatori di processo sono dotati di un contatto ausiliario che può essere asservito ad una situazione di allarme rilevata dal dispositivo. Questo contatti sono collegati a ingressi del PLC. Le azioni in conseguenza di una condizione di allarme verranno gestite in funzione delle esigenze di esercizio impianto e definite al termine del periodo di collaudo.

4.18 Scelta classe resistenza tiranti flange impianto

Per le flange presenti nel circuito prova barre sono stati scelti bulloni con classe di resistenza 8.8.

Nel circuito sono presenti 5 tipi di flange diversi :

- flangia da 2" ANSI 2500 LM/LF
- flangia da 1" ANSI 2500 LM/LF
- flangia da 3/4" ANSI 2500 LM/LF
- flangia da 3" ANSI 150 LM/LF
- flangia da 2" ANSI 150 LM/LF

In Tabella 4-6 si riportano il numero dei fori per bulloni di ogni flangia, il diametro dei fori, il diametro interno ed esterno della flangia, il bullone adatto per ciascuna flangia e la sua sezione resistente, presa dal Manuale dell'Ingegnere Meccanico [3].

Tabella 4-6: caratteristiche flange e relativi bulloni

Tipo di Flangia	Diametro ext flangia [mm]	Diametro int flangia [mm]	Numero di fori per bulloni	Diametro fori [mm]	Diametro bullone	Sez Res bullone [mm²]
	E_{ext}	D_{int}	N_b			S_R
2" ANSI 2500	92.10	42.80	8.00	28.50	M27	459.00
1" ANSI 2500	50.80	24.30	4.00	25.40	M24	353.00
3/4" ANSI 2500	42.90	18.90	4.00	22.50	M20	245.00
3" ANSI 150	127.00	77.90	4.00	19.00	M18	192.00
2" ANSI 150	92.10	52.50	4.00	19.00	M18	192.00

Per valutare la classe di resistenza dei tiranti/bulloni, si è ricorso alla seguente formula, che calcola la forza su ciascuna flangia:

$$F = \frac{D_{int}^2 \cdot \pi}{4} \cdot P_{prog} + \left(\frac{D_{ext}^2 \cdot \pi}{4} - \frac{D_{int}^2 \cdot \pi}{4} \right) \cdot P_{prog} \cdot 2 + M_{circ} \cdot g$$

Dove

g è l'accelerazione di gravità, pari a 9.806

P_{prog} è la pressione di progetto dell'impianto, pari a 172.5 bar

M_{circ} è la massa dell'impianto, pari a 2500 kg.

Una volta ricavata la forza, si è calcolato il carico unitario di rottura R_m per ciascun bullone, dividendo la forza che agisce su una flangia per il numero di bulloni moltiplicati la loro sezione resistente:

$$R_m = \frac{F}{S_R \cdot N_b}$$

I valori ottenuti sono stati confrontati con il carico unitario di rottura ammissibile R_{ma} per bulloni di classe di resistenza 8.8. Come si riscontra, il valore calcolato è ampiamente al di sotto del valore massimo ammissibile, pertanto i bulloni scelti sono idonei a resistere al carico cui sono soggetti. La Tabella 4-7 presenta, per ciascuna flangia, la forza agente, il carico di rottura calcolato e quello ammissibile.

Tabella 4-7: carico di rottura per bulloni 8.8 e relative flange

Tipo di Flangia	Forza	Carico di rottura calcolato	Carico di rottura ammissibile per bulloni di classe 8.8
	F	R_m	R_{ma}
2" ANSI 2500	229538.40	62.51	800
1" ANSI 2500	86440.60	61.22	800
3/4" ANSI 2500	69543.66	70.96	800
3" ANSI 150	379334.66	493.93	800
2" ANSI 150	217014.39	282.57	800

5 RIFERIMENTI

- [1] C. Congiu, M. Greco - 01510RT09rev0: Impianto prova barre – Progetto esecutivo: caratteristiche e dimensionamento
- [2] A. Achilli, S. Gandolfi, R. Ferri - Rod characteristics rev.7 - draft
- [3] Hoepli - Manuale dell'Ingegnere Meccanico

Elenco allegati

Allegato 1	Lista materiali certificati: Disegno 074-00-01rev3 tav. 1, zona barre
Allegato 2	Lista materiali certificati: Disegno 074-00-01rev3 tav. 2, tratto uscita zona barre
Allegato 3	Lista materiali certificati: Disegno 074-00-01rev3 tav. 3, tratto orizzontale superiore
Allegato 4	Lista materiali certificati: Disegno 074-00-01rev3 tav. 4, tratto discendente
Allegato 5	Lista materiali certificati: Disegno 074-00-01rev3 tav. 5, esterno scambiatore
Allegato 6	Lista materiali certificati: Disegno 074-00-01rev3 tav. 6, venturimetro
Allegato 7	Lista materiali certificati: Disegno 074-00-01rev3 tav. 7, tronchetto a valle venturimetro
Allegato 8	Lista materiali certificati: Disegno 074-00-01rev3 tav. 8, tratto orizzontale inferiore
Allegato 9	Lista materiali certificati: Disegno 074-00-01rev3 tav. 9, EBT
Allegato 10	Lista materiali certificati: Disegno 074-00-01rev3 tav. 10, EBT scambiatore
Allegato 11	Lista materiali certificati: Disegno 074-00-01rev3 tav. 13, tenuta
Allegato 12	Documentazione valvola di sicurezza
Allegato 13	Documentazione venturimetro
Allegato 14	Documentazione valvola gate valve
Allegato 15	Documentazione valvole e manifold
Allegato 16	Documentazione valvole e manifold
Allegato 17	Qualifica saldatore interno (WPQ)
Allegato 18	Qualifica saldatore esterno (WPQ)
Allegato 19	Controllo visivo saldature
Allegato 20	Controllo dimensionale
Allegato 21	Dichiarazione di conformità al progetto
Allegato 22	Dichiarazione di conformità alla fabbricazione ed installazione
Allegato 23	Dichiarazione di conformità alla prova idraulica
Allegato 24	Certificato di prova idraulica
Allegato 25	Dichiarazione di conformità CE
Allegato 26	Specifica tecnica barre scaldanti primo fornitore
Allegato 27	Specifica tecnica barre scaldanti secondo fornitore
Allegato 28	Posizione termocoppie su barra scaldante per primo fornitore
Allegato 29	Posizione termocoppie su barra scaldante per secondo fornitore
Allegato 30	Calcolo ΔT barretta
Allegato 31	Specifica tecnica kalrez
Allegato 32	Calcoli strutturali e risultati con Autopipe Plus V8.i
Allegato 33	Specifica tecnica e disegno candela del pressurizzatore

Allegato 1:

Lista materiali certificati: Disegno 074-00-01rev3 tav. 1, zona barre



LISTA MATERIALI CERTIFICATI

DATA	17/06/10	PAGINA	1	di	1
Assieme					
IMPIANTO PROVA BARRE					
N°Riferimento Disegno	074.00.01	Rev.:	3	Tav. 1 rev. 2	Data: 21/06/2010

Part. N°	Descrizione	Quantità	Lunghezza (mm)	Materiale	N° Certificato	Data Certificato	Fabbricante	N° di colata	Note
4	Flangia WN 2" ansi 2500 LM	1	-	ASTM A182 F 304	53/10-1	29/04/'10	Steeltrade	379250	
25	Flangia WN 2" ansi 2500 LF	2	-	"	"	"	"	"	
30/1	Tubo 2" sch.160	1	510	ASTM AISI 304	428723	06/10/'09	T.T.I. Tubacex	41544	
30/2	Tubo ½" sch. 80	2	125	"	428715	06/10/'09	T.T.I. Tubacex	41431	
30/3	Tee 2" sch. 160	1	-	ASTM WP316	080903-17	09/03/'08	LIXUE Steel Pipe	A327	
30/4	Tubo 2" sch.160	1	5411	ASTM AISI 304	428723	06/10/'09	T.T.I. Tubacex	41544	
30/5	Tubo 2" sch.160	1	113	"	"	"	"	"	

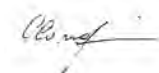
Compilato da: 	Data: 21/06/2010
---	------------------

CERTIFICATE OF CHEMICAL ANALYSIS AND MECHANICAL TEST.



STEELTRADE s.r.l.
 Loc. CATTAGNINA
 29010 ROTTOFRENO (PC) - ITALY
 TEL. +39 0523 780121
 FAX +39 0523 780123
 E-mail: inspection@steeltrade.it
 WEB: http://www.steeltrade.it

CERTIFICATE N. :53/10-1
 DATED :29/04/10

PURCHASER : SIET

YOUR ORDER : 74-10

JOB N. : ST 53/10

ITEM	Q.TY N°	DESCRIPTION	MATERIAL	HEAT CODE	HEAT
ITEM 01	4	WN FLANGE 1" LARGE MALE SCH.80 ANSI 2500	ASTM A182 F304	0B3	374150
ITEM 02	6	WN FLANGE 1" LARGE FEMALE SCH.80 ANSI 2500	ASTM A182 F304	B540	508471
ITEM 03	1	SLIP ON FLANGE 3" RF CL150	ASTM A182 F304	B248	259170
ITEM 04	1	SLIP ON FLANGE 2" RF CL150	ASTM A182 F304	B140	21728
ITEM 05	1	BLIND FLANGE 3" RF CL600 FORATA DIAM. 61 mm	ASTM A182 F304	B254	444625
ITEM 06	1	BLIND FLANGE 2" RF CL150 FORATA DIAM. 34 mm	ASTM A182 F304	B266	D82126A
ITEM 07	8	WN FLANGE 2" LARGE MALE SCH.160 ANSI 2500	ASTM A182 F304	B500	379250
ITEM 08	9	WN FLANGE 2" LARGE FEMALE SCH.160 ANSI 2500	ASTM A182 F304	B500	379250
ITEM 09	1	WN FLANGE 3/4" LARGE MALE SCH.160 ANSI 2500	ASTM A182 F304	B273	291450
ITEM 10	1	WN FLANGE 3/4" LARGE FEMALE SCH.160 ANSI 2500	ASTM A182 F304	B273	291450

Chemical Analysis

HEAT	C%	Mn%	Si%	P%	S%	Mo%	Cr%	Ni%	V%	Cu%	Ti%	Nb%	C.eq% *
374150	0.023	1.78	0.35	0.0028	0.0021		18.43	8.91					
508471	0.009	1.12	0.40	0.028	0.0026		18.14	9.12					
259170	0.014	1.75	0.31	0.026	0.024		18.33	8.14					
21728	0.017	0.77	0.32	0.028	0.002		18.25	9.20					
444625	0.013	1.10	0.41	0.026	0.026		18.20	9.22					
D82126A	0.019	1.61	0.42	0.025	0.025		18.26	10.17					
379250	0.022	1.71	0.24	0.03	0.021		18.22	8.93					
291450	0.022	1.76	0.31	0.029	0.026		18.32	8.20					

Mechanical Properties

HEAT	TENSILE TEST					IMPACT TEST					
	Tensile strength N/mm2	Yield point N/mm2	Elongation 2" %	Red. of Area %	Hardness HB	Type	Section	Temp.	Values J	Values J	Values J
374150	606	341	47.2	60.3							
508471	549	348	52.6	74.8							
259170	582	241	61.0	70.4							
21728	525	375	49.0	73.0							
444625	577	278	57.0	69.0							
D82126A	576	242	53.0	71.0							
379250	576	281	57.0	72.6							
291450	580	274	59.7	75.0							

NOTE:

- CERTIFICATE CONFORM TO : EN 10204.3.1
- STEEL MADE BY ELECTRIC FURNACE
- HEAT TREATMENT : SOLUTION ANNEALED
- ACCORDING TO PED 97/23/EC ANNEX 1 PAR.4.3
- PMI : NO OBJECTION (100% TESTED WITH NITON ANALYZER)
- DIMENSIONS : ASME B16.5
- VISUAL AND DIMENSIONAL TEST : SATISFACTORY

Quality Control
STEELTRADE



*C. eq. by long formula

The present certificate is in fully accordance with UNI CEI EN 45014-90



T.T.I. - Tubacex Tubos Inoxidables, S.A.

Registro Mercantil de Alava, Tomo 587, Folio 198, Hoja VI 2886 - N.I.F. A-01140227

Printed on:
21.10.2009

INSPECTION CERTIFICATE

EN 10204 3.1

Number: 428723

Page: 1 / 2

Rev: 0

Date: 06.10.2009

06.10.2009

CUSTOMER : PO : **C02989*** OUR REFERENCE: **K0002**
 STANDARD : **EN 10216-5 TC2**
 ADDIT. SPECS : **NACE MR01.75-03 / NACE MR03-03 / ISO 15156-3**
 GRADE : **1.4301/1.4306**
 DIMENSIONS : **60,32 X 8,74**
 MATERIAL : **SEAMLESS STAINLESS STEEL TUBE**
COLD ROLLED; PICKLED-PASSIVATED;
PLAIN BEVELLED ENDS;

ITEM	HEAT	NO. OF	WEIGHT	TOTAL LENGTH	UNIT LENGTH	
YOUR	TTI.	PIECES	KG			
	66	41544	28	1933	172,52	5,5 - 6,5 MT

RAW MATERIAL

MELTING PROCESS: ELECTRIC FURNACE + A.O.D FROM: ACERALAVA
 PEELED BARS; MACROETCH TESTING: GOOD;

CHEMICAL COMPOSITION (*1 L: LADLE; C: PRODUCT)

*1 HEAT	C	Mn	Si	P	S	Ni	Cr	N
L 41544	0,017	1,50	0,300	0,027	0,0010	10,15	18,30	0,0720

HEAT TREATMENT

SOLUTION ANNEALED 1100 °C HOLDING TIME >=1.5 MIN/MM WATER QUENCHED

TESTS		TENSION				IMPACT TESTS		HARDNESS	
NR.	NR.	T(°C)	MPA	RP 0,2	RP 1,0	A	Z	T(°C) MINIMUM AVERAGE	HRB
HEAT	TEST								
41544	908135	20	550,0	321,0	369,0	46,7			81 82
41544	908135A	20	550,0	322,0	369,0	45,3			81 82

TECHNOLOGICALS

FLATTENING TEST: GOOD
 RING EXPANDING TEST: GOOD

METALLURGICAL TEST

INTERGRANULAR CORROSION: A262 "E"/ISO 3651-2/ 5 TEST ACC.MIL-P-1144D+24691/3: GOOD

NON DESTRUCTIVE TEST

100 % U.T TO EN10246-7 (ENT.5%, MIN.0,3MM) , GOOD
 100 % EDDY CURRENT TEST AT E-426 , GOOD
 100 % HYDROSTATIC PRESSURE TESTED AT 80 BAR , DURING 5 SEC, GOOD
 STEEL GRADE CHECKING ON EACH TUBE BY SPECTROMETRY (PMI): SATISFACTORY
 DIMENSIONAL CHECKING ON EACH TUBE, SATISFACTORY
 VISUAL INSPECTION ON EACH TUBE, SATISFACTORY



OTHER MATERIAL SPECIFICATIONS

A/SA312M-08A ED.07 + 08 ADD TP304-304L
 A/SA376M-06 ED.07 + 08 ADD TP304

MARKS

TX2
 TUBACEX 60,32 X 8,74 EN 10216-5 TC2 1.4301-1.4306 CFD ASTM-ASME
 A-SA 312 TP304-304L A-SA 376 TP304 SMLS HEAT/..... PMI TX2
 SPAIN

REMARKS

TOL. ISO 1127 D3-T3 / ASTM A999
 NO WELD REPAIR WAS PERFORMED

COPIA CONFORME ALL'ORIGINALE



We hereby certify that the material herein described has been manufactured, sampled, tested and inspected in accordance with above standards and specifications and satisfies the order's requirements.
 This certificate is issued by a computerized system and it is valid without original signature. In case the owner of this certificate would request a copy of it, he must advise its conformity to the issuer, assuming the responsibility for any unlawful or T.T.I.,S.A. not allowed use.
 Any forgery or falsification of this certificate shall legally prosecuted.

T.T.I.
 Tubacex Tubos Inoxidables, S.A.

INGENIERIA DE CALIDAD

[Signature]
 JON ARBIDE ZUBEROA



T.T.I. - Tubacex Tubos Inoxidables, S.A.

Registro Mercantil de Álava, Tomo 587, Folio 188, Hoja VI 2886 - N.I.F. A-61140227

Printed on:
21.10.2009

INSPECTION CERTIFICATE

EN 10204 3.1

Number: 428723
Page: 2 / 2

Rev: 0

Date: 06.10.2009 06.10.2009

CUSTOMER : PO : **C02989*** OUR REFERENCE: **K0002**

STANDARD : **EN 10216-5 TC2**

ADDIT. SPECS : **NACE MR01.75-03 / NACE MR03-03 / ISO 15156-3**

GRADE : **1.4301/1.4306**

DIMENSIONS : **60,32 X 8,74**

MATERIAL : **SEAMLESS STAINLESS STEEL TUBE**
COLD ROLLED; PICKLED-PASSIVATED;
PLAIN BEVELLED ENDS;

MATERIAL MANUFACTURER APPROVED WITH CERTIFICATE NR. 07/2001/MUC BY TÜV SÜDDEUTSCHLAND (NOTIFIED BODY 0036) TO ISSUE CERTIFICATES OF SPECIFIC PRODUCT CONTROL IN ACCORDANCE WITH PRESSURE EQUIPMENT DIRECTIVE 97/23/EC ANNEX 1 POINT 4.3. MATERIAL CHARACTERISTICS COMPLY WITH POINT 7.5 OF ANNEX I TO PED BY HAVING AN ELONGATION AFTER RUPTURE AT TENSILE TEST NO LESS THAN 14 % AND A BENDING RUPTURE ENERGY AT IMPACT TEST NO LESS THAN 27 J AT 20°C.



We hereby certify that the material herein described has been manufactured, sampled, tested and inspected in accordance with above standards and specifications and satisfies the order's requirements.

This certificate is issued by a computerized system and it is valid without original signature. In case the owner of the certificate would release a copy of it, he must state its conformity to the issued, assuming the responsibility for any unlawful or T.T.I.S.A. not allowed use.

Any forgery or falsification of this certificate shall legally prosecuted.

T.T.I. Tubacex Tubos Inoxidables, S.A.

INGENIERIA DE CALIDAD

[Signature]
Jon Albano Zubizarreta



T.T.I. - Tubacex Tubos Inoxidables, S.A.

Registro Mercantil de Alava, Tomo 587, Folio 188, Hoja VI 2888 - N.I.F. A-41140227

Printed
19.01.

INSPECTION CERTIFICATE

EN 10204 3.1

Number: 417490
Page: 1 / 2

Rev: 6

Date: 19.12.2008

19.12.2008

CUSTOMER : PO : **C02647** OUR REFERENCE: **J9378**
 STANDARD : **DIN 17450 PK1/EN 10216-5 TC1 AD-2000 W2/W10/TRD100**
 ADDIT. SPECS : **NACE MR01.75-03 / ISO 15156**
 GRADE : **1.4301/1.4306**
 DIMENSIONS : **21,34 X 3,73**
 MATERIAL : **SEAMLESS STAINLESS STEEL TUBE**
COLD ROLLED; PASSIVATED;
PLAIN ENDS SQUARE CUT;

---ITEM---	---HEAT---	NO. OF	---WEIGHT---	---TOTAL LENGTH---	---UNIT LENGTH---
YOUR	TTI.	PIECES	KG		
	3 40405	113	1152	686,90	5,5 - 6,5 MT

RAW MATERIAL

MELTING PROCESS: ELECTRIC FURNACE + A.O.D FROM: ACERALAVA
 PEELED BARS; MACROETCH TESTING: GOOD;

CHEMICAL COMPOSITION (*1 L: LADLE; C: PRODUCT)

*1 HEAT	C	Mn	Si	P	S	Ni	Cr	Cu	B	N
L 40405	0,012	1,49	0,290	0,032	0,0010	10,15	18,25	0,34	0,0009	0,0720



HEAT TREATMENT

SOLUTION ANNEALED 1100 °C HOLDING TIME >=1.5 MIN/MM WATER QUENCHED

= TESTS =		-----TENSION-----				--IMPACT TESTS--		HARDNESS			
NR.	TEST	T(°C)	MPA	R _m	R _p 0,2	R _p 1,0	A	Z	T(°C) MINIMUM	AVERAGE	HRB
40405	813809	20	603,0	303,0	345,0	58,8					85 86

TECHNOLOGICALS

FLATTENING TEST: GOOD
 FLARING TEST: GOOD
 RING EXPANDING TEST: GOOD

METALLURGICAL TEST

INTERGRANULAR CORROSION: A.262 PRACT. "E" / ISO 3651-2 : NOT OBJECTIONS

NON DESTRUCTIVE TEST

100 % HYDROSTATIC PRESSURE TESTED AT 80 BAR , DURING 6 SEC, GOOD
 STEEL GRADE CHECKING ON EACH TUBE BY SPECTROMETRY (PMI): SATISFACTORY
 DIMENSIONAL CHECKING ON EACH TUBE, SATISFACTORY
 VISUAL INSPECTION ON EACH TUBE, SATISFACTORY

OTHER MATERIAL SPECIFICATIONS

A-SA312M-06 ED.07/NF A49117-85 TP304-304L/Z2-Z6 CN 18.10-09

MARKS

TX2
 TUBACEX 21,34 X 3,73 1.4301-1.4306 H S 1 - EN 10216-5 TC1 1.4301-
 1.4306 CFD - NF A49-117 Z2-Z6 CN 18.10-09 - A-SA 312 TP304-304L **SMUS**
 HEAT/..... PMI TX2 SPAIN

REMARKS

TOL.ISO T32 D3/T3
 MATERIAL MANUFACTURER APPROVED WITH CERTIFICATE NR. 07/2001/MUC BY TÜV SÜDDEUTSCHLAND
 (NOTIFIED BODY 0036) TO ISSUE CERTIFICATES OF SPECIFIC PRODUCT CONTROL IN
 ACCORDANCE WITH PRESSURE EQUIPMENT DIRECTIVE 97/23/EC ANNEX 1 POINT 4.3.
 AS PER LETTER DATED 21.08.92 TÜV SÜDWEST DECLINES COUNTERSIGNING
 MATERIAL CHARACTERISTICS COMPLY WITH POINT 7.5 OF ANNEX I TO PED BY HAVING AN ELONGATION
 AFTER RUPTURE AT TENSILE TEST NO LESS THAN 14 % AND A BENDING RUPTURE ENERGY AT IMPACT TE



We hereby certify that the material herein described has been manufactured, sampled, tested and inspected in accordance with above standards and specifications and satisfies the order's requirements.
 This certificate is issued by a computerized system and it is valid without original signature.
 In case the owner of the certificate would release a copy of it, he must accept its conformity to the issued, assuming the responsibility for any misuse of T.T.I., S.A. not allowed use.
 Any forgery or falsification of this certificate shall legally prosecuted.

T.T.I.
 Tubacex Tubos Inoxidables, S.A.

INGENIERIA DE CALIDAD



Juan Alana Zubizar



TUBACEX

T.T.I. - Tubacex Tubos Inoxidables, S.A.

Registro Mercantil de Aleva, Tomo 587, Folio 189, Hoja VI 2005 - N.I.F. A-01148227

Printed on:
19.01.2009

INSPECTION CERTIFICATE

EN 10204 3.1

Number: 417490
Page: 2 / 2

Rev: 0

Date: 19.12.2008

19.12.2008

CUSTOMER : PO : **C02647** OUR REFERENCE: **J9378**
 STANDARD : **DIN 17458 PK1/EN 10216-5 TC1 AD-2000 W2/W10/TRD100**
 ADDIT. SPECS : **NACE MR01.75-03 / ISO 15156**
 GRADE : **1.4301/1.4306**
 DIMENSIONS : **21,34 X 3,73**
 MATERIAL : **SEAMLESS STAINLESS STEEL TUBE**
COLD ROLLED; PASSIVATED;
PLAIN ENDS SQUARE CUT;

ST NO LESS THAN 27 J AT 20°C.

CONFORME ALL'ORIGINALE
RUBIVAL INOX S.R.L.



We hereby certify that the material herein described has been manufactured, sampled, tested and inspected in accordance with above standards and specifications and satisfies the order's requirements.
The certificate is issued by a computerized system and it is valid without original signature.
In case the owner of the certificate would release a copy of it, he must attend its conformity to the issued, assuming the responsibility for any error or T.T.I. S.A. not identical use.
Any forgery or falsification of this certificate shall legally prosecuted.

T.T.I.
Tubacex Tubos Inoxidables, S.A.

INGENIERIA DE CALIDAD

[Signature]
Joni Alzola Zubizarreta

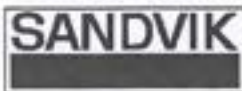

CertificateNo

80903-17

1(2)

Date

2010-04-13

Riferimenti del cliente

Indirizzo del cliente

SIG.MARINELLI
R.T.I. SPA
VIA AMBROSOLI 2/A
20090 RODANO MILLEPINI MI
Italy

Codice prodotto Cliente

FBT-316L-2-160

Numero d'ordine

ORD.29616/10 6.4

Riferimenti di Sandvik

Codice prodotto Sandvik

FBT-316L-2-160

Lunghezza

Lotto

Colata

A327

Quantità consegnata

1 Pieces

Numero d'ordine del cliente

255674

Linea d'ordine del cliente

2

DDT Nr

16139

SANDVIK ITALIA SPA

Divisione Acciai

QUALITY ASSURANCE REPRESENTATIVE

Vittorino Veronese



LIXUE STEEL PIPE CO.LTD

TINGTIAN INDUSTRIAL ZONE, RUJIAN CITY, ZHEJIANG CHINA

MILL TEST CERTIFICATE IN ACC. WITH EN 10204/3.1(EN 10204/3.1 DIN 50049/3.1) ISO9001:2000 PED:97/23/EC

Client		Santrade Ltd		Certificate No		080903-17	
Contract NO		F20090706		Delivery Conditions		Solution Annealed, pickled and passivated	
Product		STAINLESS STEEL COLD FORMED BUTT WELD FITTINGS		Specification		ASTM/A586 A586-08 ANSI B16.9-03	
Item	Quantity	Size	Description	Grade	Heat NO	Heat treatment	Quenching
113	190	1 1/2"	SCH40S Equal Tees	WP316/316L-S	B189	1052* 15 min	RWQ
114	100	1 1/2"	SCH80S Equal Tees	WP316/316L-S	YD08-024	1052* 15 min	RWQ
115	10	1 1/2"	SCH160 Equal Tees	WP316/316L-S	2609	1052* 15 min	RWQ
116	300	2"	SCH10S Equal Tees	WP316/316L-S	620	1052* 15 min	RWQ
117	240	2"	SCH40S Equal Tees	WP316/316L-S	YD08-024	1052* 15 min	RWQ
118	50	2"	SCH80S Equal Tees	WP316/316L-S	YD08-103	1052* 15 min	RWQ
119	10	2"	SCH160 Equal Tees	WP316/316L-S	A327	1052* 15 min	RWQ

Chemical Composition (%)									
Heat	C	Min	P	S	Si	Cr	Ni	Mo	Ti
B189	0.024	0.93	0.041	0.002	0.44	16.42	10.22	2.08	
YD08-024	0.020	0.87	0.039	0.005	0.43	16.70	10.15	2.07	
2609	0.017	0.85	0.036	0.007	0.39	16.54	11.09	2.04	
620	0.020	0.99	0.040	0.005	0.43	16.39	10.08	2.06	
YD08-024	0.020	0.87	0.039	0.005	0.43	16.70	10.15	2.07	
YD08-103	0.025	0.75	0.035	0.002	0.58	16.40	10.05	2.05	
A327	0.025	0.92	0.036	0.005	0.48	16.17	10.08	2.04	

Mechanical Properties									
Heat	TS(Mpa)	YS (Mpa)	EL(%)	Hardness		IC Test ASTM A262E	Impact Test	Non-destructive Test	
				HRB≤90	HRB≤90			PT	PMI
B189	550	240	60	HRB≤90	HRB≤90	OK	N/A	OK	OK
YD08-024	805	305	60	HRB≤90	HRB≤90	OK	N/A	OK	OK
2609	620	270	64	HRB≤90	HRB≤90	OK	N/A	OK	OK
620	605	285	64	HRB≤90	HRB≤90	OK	N/A	OK	OK
YD08-024	600	325	50	HRB≤90	HRB≤90	OK	N/A	OK	OK
YD08-103	540	245	60	HRB≤90	HRB≤90	OK	N/A	OK	OK
A327	630	295	60	HRB≤90	HRB≤90	OK	N/A	OK	OK

MARKINGS: LIXUE - SPEC - SIZE - SCH - GRADE - HEAT NO
Materials have been manufactured in complete accordance with the Purchasers order

SANDVIK ITALIA S.p.A.
REVIEWED

Signed: [Signature] 23.09.2008
Date: 2008.09.03
QA Manager



PO NO: 23465

Allegato 2:

Lista materiali certificati: Disegno 074-00-01rev3 tav. 2,
tratto uscita zona barre

Assieme

IMPIANTO PROVA BARRE

N°Riferimento Disegno

074.00.01

Rev.:

3

Tav. 2 rev .2

Data:

21/06/2010

Part. N°	Descrizione	Quantità	Lunghezza (mm)	Materiale	N° Certificato	Data Certificato	Fabbricante	N° di colata	Note
4	Flangia WN 2" ansi 2500 LM	1	-	ASTM A182 F 304	53/10-1	29/04/'10	Steeltrade	379250	
25	Flangia WN 2" ansi 2500 LF	1	-	"	"	"	"	"	
31	Tube 2" sch.160	1	2463	ASTM AISI 304	428723	06/10/'09	T.T.I. Tubacex	41544	

Compilato da: 

Data: 21/06/2010

CERTIFICATE OF CHEMICAL ANALYSIS AND MECHANICAL TEST.



STEELTRADE s.r.l.
 Loc. CATTAGNINA
 29010 ROTTOFRENO (PC) - ITALY
 TEL. +39 0523 780121
 FAX +39 0523 780123
 E-mail: inspection@steeltrade.it
 WEB: http://www.steeltrade.it

CERTIFICATE N. :53/10-1
 DATED :29/04/10

PURCHASER : SIET

YOUR ORDER : 74-10

JOB N. : ST 53/10

ITEM	Q.TY N°	DESCRIPTION	MATERIAL	HEAT CODE	HEAT
ITEM 01	4	WN FLANGE 1" LARGE MALE SCH.80 ANSI 2500	ASTM A182 F304	0B3	374150
ITEM 02	6	WN FLANGE 1" LARGE FEMALE SCH.80 ANSI 2500	ASTM A182 F304	B540	508471
ITEM 03	1	SLIP ON FLANGE 3" RF CL150	ASTM A182 F304	B248	259170
ITEM 04	1	SLIP ON FLANGE 2" RF CL150	ASTM A182 F304	B140	21728
ITEM 05	1	BLIND FLANGE 3" RF CL600 FORATA DIAM. 61 mm	ASTM A182 F304	B254	444625
ITEM 06	1	BLIND FLANGE 2" RF CL150 FORATA DIAM. 34 mm	ASTM A182 F304	B266	D82126A
ITEM 07	8	WN FLANGE 2" LARGE MALE SCH.160 ANSI 2500	ASTM A182 F304	B500	379250
ITEM 08	9	WN FLANGE 2" LARGE FEMALE SCH.160 ANSI 2500	ASTM A182 F304	B500	379250
ITEM 09	1	WN FLANGE 3/4" LARGE MALE SCH.160 ANSI 2500	ASTM A182 F304	B273	291450
ITEM 10	1	WN FLANGE 3/4" LARGE FEMALE SCH.160 ANSI 2500	ASTM A182 F304	B273	291450

Chemical Analysis

HEAT	C%	Mn%	Si%	P%	S%	Mo%	Cr%	Ni%	V%	Cu%	Ti%	Nb%	C.eq% *
374150	0.023	1.78	0.35	0.0028	0.0021		18.43	8.91					
508471	0.009	1.12	0.40	0.028	0.0026		18.14	9.12					
259170	0.014	1.75	0.31	0.026	0.024		18.33	8.14					
21728	0.017	0.77	0.32	0.028	0.002		18.25	9.20					
444625	0.013	1.10	0.41	0.026	0.026		18.20	9.22					
D82126A	0.019	1.61	0.42	0.025	0.025		18.26	10.17					
379250	0.022	1.71	0.24	0.03	0.021		18.22	8.93					
291450	0.022	1.76	0.31	0.029	0.026		18.32	8.20					

Mechanical Properties

HEAT	TENSILE TEST					IMPACT TEST					
	Tensile strength N/mm2	Yield point N/mm2	Elongation 2" %	Red. of Area %	Hardness HB	Type	Section	Temp.	Values J	Values J	Values J
374150	606	341	47.2	60.3							
508471	549	348	52.6	74.8							
259170	582	241	61.0	70.4							
21728	525	375	49.0	73.0							
444625	577	278	57.0	69.0							
D82126A	576	242	53.0	71.0							
379250	576	281	57.0	72.6							
291450	580	274	59.7	75.0							

NOTE:

- CERTIFICATE CONFORM TO : EN 10204.3.1
- STEEL MADE BY ELECTRIC FURNACE
- HEAT TREATMENT : SOLUTION ANNEALED
- ACCORDING TO PED 97/23/EC ANNEX 1 PAR.4.3
- PMI : NO OBJECTION (100% TESTED WITH NITON ANALYZER)
- DIMENSIONS : ASME B16.5
- VISUAL AND DIMENSIONAL TEST : SATISFACTORY

Quality Control
STEELTRADE



*C. eq. by long formula

The present certificate is in fully accordance with UNI CEI EN 45014-90



T.T.I. - Tubacex Tubos Inoxidables, S.A.

Registro Mercantil de Alava, Tomo 587, Folio 198, Hoja VI 2886 - N.I.F. A-01140227

Printed on:
21.10.2009

INSPECTION CERTIFICATE

EN 10204 3.1

Number: 428723

Page: 1 / 2

Rev: 0

Date: 06.10.2009

06.10.2009

CUSTOMER : PO : **C02989*** OUR REFERENCE: **K0002**
 STANDARD : **EN 10216-5 TC2**
 ADDIT. SPECS : **NACE MR01.75-03 / NACE MR03-03 / ISO 15156-3**
 GRADE : **1.4301/1.4306**
 DIMENSIONS : **60,32 X 8,74**
 MATERIAL : **SEAMLESS STAINLESS STEEL TUBE**
COLD ROLLED; PICKLED-PASSIVATED;
PLAIN BEVELLED ENDS;

---ITEM---	---HEAT---	NO. OF	---WEIGHT---	---TOTAL LENGTH---	---UNIT LENGTH---	
YOUR	TTI.	PIECES	KG			
	66	41544	28	1933	172,52	5,5 - 6,5 MT

RAW MATERIAL

MELTING PROCESS: ELECTRIC FURNACE + A.O.D FROM: ACERALAVA
 PEELED BARS; MACROETCH TESTING: GOOD;

CHEMICAL COMPOSITION (*1 L: LADLE; C: PRODUCT)

*1 HEAT	C	Mn	Si	P	S	Ni	Cr	N
L 41544	0,017	1,50	0,300	0,027	0,0010	10,15	18,30	0,0720

HEAT TREATMENT

SOLUTION ANNEALED 1100 °C HOLDING TIME >=1.5 MIN/MM WATER QUENCHED

- TESTS -		-----TENSION-----				---IMPACT TESTS---		HARDNESS
NR.	NR.	T(°C)	---MPA---		%			HRB
HEAT	TEST		RM	RP 0,2	RP 1,0	A	Z	T(°C) MINIMUM AVERAGE
41544	908135	20	550,0	321,0	369,0	46,7		81 82
41544	908135A	20	550,0	322,0	369,0	45,3		81 82

TECHNOLOGICALS

FLATTENING TEST: GOOD
 RING EXPANDING TEST: GOOD

METALLURGICAL TEST

INTERGRANULAR CORROSION: A262 "E"/ISO 3651-2/ 5 TEST ACC.MIL-P-1144D+24691/3: GOOD

NON DESTRUCTIVE TEST

100 % U.T TO EN10246-7 (ENT.5%, MIN.0,3MM) , GOOD
 100 % EDDY CURRENT TEST AT E-426 , GOOD
 100 % HYDROSTATIC PRESSURE TESTED AT 80 BAR , DURING 5 SEC, GOOD
 STEEL GRADE CHECKING ON EACH TUBE BY SPECTROMETRY (PMI): SATISFACTORY
 DIMENSIONAL CHECKING ON EACH TUBE, SATISFACTORY
 VISUAL INSPECTION ON EACH TUBE, SATISFACTORY



OTHER MATERIAL SPECIFICATIONS

A/SA312M-08A ED.07 + 08 ADD TP304-304L
 A/SA376M-06 ED.07 + 08 ADD TP304

MARKS

TX2
 TUBACEX 60,32 X 8,74 EN 10216-5 TC2 1.4301-1.4306 CFD ASTM-ASME
 A-SA 312 TP304-304L A-SA 376 TP304 SMLS HEAT/..... PMI TX2
 SPAIN

REMARKS

TOL. ISO 1127 D3-T3 / ASTM A999
 NO WELD REPAIR WAS PERFORMED

COPIA CONFORME ALL'ORIGINALE



We hereby certify that the material herein described has been manufactured, sampled, tested and inspected in accordance with above standards and specifications and satisfies the order's requirements.
 This certificate is issued by a computerized system and it is valid without original signature. In case the owner of this certificate would request a copy of it, he must advise its conformity to the issuer, assuming the responsibility for any unlawful or T.T.I.,S.A. not allowed use.
 Any forgery or falsification of this certificate shall legally prosecuted.

T.T.I.
 Tubacex Tubos Inoxidables, S.A.

INGENIERIA DE CALIDAD

[Signature]
 JON ARBUI ZUBERO



T.T.I. - Tubacex Tubos Inoxidables, S.A.

Registro Mercantil de Álava, Tomo 587, Folio 188, Hoja VI 2886 - N.I.F. A-61140227

Printed on:
21.10.2009

INSPECTION CERTIFICATE

EN 10204 3.1

Number: 428723
Page: 2 / 2

Rev: 0

Date: 06.10.2009 06.10.2009

CUSTOMER : PO : **C02989*** OUR REFERENCE: **K0002**

STANDARD : **EN 10216-5 TC2**

ADDIT. SPECS : **NACE MR01.75-03 / NACE MR03-03 / ISO 15156-3**

GRADE : **1.4301/1.4306**

DIMENSIONS : **60,32 X 8,74**

MATERIAL : **SEAMLESS STAINLESS STEEL TUBE**
COLD ROLLED; PICKLED-PASSIVATED;
PLAIN BEVELLED ENDS;

MATERIAL MANUFACTURER APPROVED WITH CERTIFICATE NR. 07/2001/MUC BY TÜV SÜDDEUTSCHLAND (NOTIFIED BODY 0036) TO ISSUE CERTIFICATES OF SPECIFIC PRODUCT CONTROL IN ACCORDANCE WITH PRESSURE EQUIPMENT DIRECTIVE 97/23/EC ANNEX 1 POINT 4.3. MATERIAL CHARACTERISTICS COMPLY WITH POINT 7.5 OF ANNEX I TO PED BY HAVING AN ELONGATION AFTER RUPTURE AT TENSILE TEST NO LESS THAN 14 % AND A BENDING RUPTURE ENERGY AT IMPACT TEST NO LESS THAN 27 J AT 20°C.



We hereby certify that the material herein described has been manufactured, sampled, tested and inspected in accordance with above standards and specifications and satisfies the order's requirements.

This certificate is issued by a computerized system and it is valid without original signature. In case the owner of the certificate would release a copy of it, he must state its conformity to the issued, assuming the responsibility for any untruth or T.T.I.S.A. not allowed use.

Any forgery or falsification of this certificate shall legally prosecuted.

T.T.I. Tubacex Tubos Inoxidables, S.A.

INGENIERIA DE CALIDAD

[Signature]
Jon Albano Zubizarreta

Allegato 3:

Lista materiali certificati: Disegno 074-00-01rev3 tav. 3,
tratto orizzontale superiore

Assieme

IMPIANTO PROVA BARRE

N°Riferimento Disegno

074.00.01

Rev.:

3

Tav. 3 rev.2

Data:

25/06/2010

Part. N°	Descrizione	Quantità	Lunghezza (mm)	Materiale	N°Certificato	Data Certificato	Fabbricante	N°di colata	Note
25	Flangia WN 2" ansi 2500 LF	2	-	ASTM A182 F 304	53/10-1	29/04/'10	Steeltrade	379250	
32/1	Tubo 2" sch.160	1	81	ASTM AISI 304	428723	06/10/'09	T.T.I. Tubacex	41544	
32/2	Curva 90°LR 2" sch.160	2	-	ASTM WP316	201001 28-2	28/01/'10	LIXUE Group	TG080059	
32/3	Tee rid. 2"x3/4" SW serie 6000	1	-	ASTM A182 F 304	00696/001	08/04/'10	OMSA	873477	
32/4	Tubo 2" sch.160	1	1594	ASTM AISI 304	428723	06/10/'09	T.T.I. Tubacex	41544	
32/5	Tee rid. 2"x1/2" SW serie 6000	1	-	ASTM A182 F 304	00696/001	08/04/'10	OMSA	873477	
32/6	Tee rid. 2"x1" SW serie 6000	1	-	ASTM A182 F 304	00696/001	08/04/'10	OMSA	873477	
32/7	Tubo 1" sch.80	1	526	ASTM AISI 304	425772	26/06/'09	T.T.I. Tubacex	41659	
32/8	Tee rid. 1"x1/2" Sch. 80	1	-	ASTM A182 F 304	6- 2009120711	07/12/'09	Zhejiang Yuli Pipeline Ind.	2P549	
32/9	Curva 90°LR 1" sch.80	1	-	ASTM WP304	091122-7	22/ 11/'09	LIXUE Group	J0701-099	
32/10	Tubo 1/2" sch.80	1	125	ASTM AISI 304	417490	19/12/'08	T.T.I. Tubacex	40405	
33b	Flangia WN 3/4" ansi 2500 LF	1	-	ASTM A182 F 304	53/10-1	29/04/'10	Steeltrade	291450	
47a	Flangia WN 1" ansi 2500 LM	1	-	ASTM A182 F 304	53/10-1	29/04/'10	Steeltrade	374150	

Compilato da:



Data:

25/06/2010

CERTIFICATE OF CHEMICAL ANALYSIS AND MECHANICAL TEST.



STEELTRADE s.r.l.
 Loc. CATTAGNINA
 29010 ROTTOFRENO (PC) - ITALY
 TEL. +39 0523 780121
 FAX +39 0523 780123
 E-mail: inspection@steeltrade.it
 WEB: http://www.steeltrade.it

CERTIFICATE N. :53/10-1
 DATED :29/04/10

PURCHASER : SIET

YOUR ORDER : 74-10

JOB N. : ST 53/10

ITEM	Q.TY N°	DESCRIPTION	MATERIAL	HEAT CODE	HEAT
ITEM 01	4	WN FLANGE 1" LARGE MALE SCH.80 ANSI 2500	ASTM A182 F304	0B3	374150
ITEM 02	6	WN FLANGE 1" LARGE FEMALE SCH.80 ANSI 2500	ASTM A182 F304	B540	508471
ITEM 03	1	SLIP ON FLANGE 3" RF CL150	ASTM A182 F304	B248	259170
ITEM 04	1	SLIP ON FLANGE 2" RF CL150	ASTM A182 F304	B140	21728
ITEM 05	1	BLIND FLANGE 3" RF CL600 FORATA DIAM. 61 mm	ASTM A182 F304	B254	444625
ITEM 06	1	BLIND FLANGE 2" RF CL150 FORATA DIAM. 34 mm	ASTM A182 F304	B266	D82126A
ITEM 07	8	WN FLANGE 2" LARGE MALE SCH.160 ANSI 2500	ASTM A182 F304	B500	379250
ITEM 08	9	WN FLANGE 2" LARGE FEMALE SCH.160 ANSI 2500	ASTM A182 F304	B500	379250
ITEM 09	1	WN FLANGE 3/4" LARGE MALE SCH.160 ANSI 2500	ASTM A182 F304	B273	291450
ITEM 10	1	WN FLANGE 3/4" LARGE FEMALE SCH.160 ANSI 2500	ASTM A182 F304	B273	291450

Chemical Analysis

HEAT	C%	Mn%	Si%	P%	S%	Mo%	Cr%	Ni%	V%	Cu%	Ti%	Nb%	C.eq% *
374150	0.023	1.78	0.35	0.0028	0.0021		18.43	8.91					
508471	0.009	1.12	0.40	0.028	0.0026		18.14	9.12					
259170	0.014	1.75	0.31	0.026	0.024		18.33	8.14					
21728	0.017	0.77	0.32	0.028	0.002		18.25	9.20					
444625	0.013	1.10	0.41	0.026	0.026		18.20	9.22					
D82126A	0.019	1.61	0.42	0.025	0.025		18.26	10.17					
379250	0.022	1.71	0.24	0.03	0.021		18.22	8.93					
291450	0.022	1.76	0.31	0.029	0.026		18.32	8.20					

Mechanical Properties

HEAT	TENSILE TEST					IMPACT TEST					
	Tensile strength N/mm2	Yield point N/mm2	Elongation 2" %	Red. of Area %	Hardness HB	Type	Section	Temp.	Values J	Values J	Values J
374150	606	341	47.2	60.3							
508471	549	348	52.6	74.8							
259170	582	241	61.0	70.4							
21728	525	375	49.0	73.0							
444625	577	278	57.0	69.0							
D82126A	576	242	53.0	71.0							
379250	576	281	57.0	72.6							
291450	580	274	59.7	75.0							

NOTE:

- CERTIFICATE CONFORM TO : EN 10204.3.1
- STEEL MADE BY ELECTRIC FURNACE
- HEAT TREATMENT : SOLUTION ANNEALED
- ACCORDING TO PED 97/23/EC ANNEX 1 PAR.4.3
- PMI : NO OBJECTION (100% TESTED WITH NITON ANALYZER)
- DIMENSIONS : ASME B16.5
- VISUAL AND DIMENSIONAL TEST : SATISFACTORY

Quality Control
STEELTRADE



*C. eq. by long formula

The present certificate is in fully accordance with UNI CEI EN 45014-90



T.T.I. - Tubacex Tubos Inoxidables, S.A.

Registro Mercantil de Alava, Tomo 587, Folio 198, Hoja VI 2886 - N.I.F. A-01140227

Printed on:
21.10.2009

INSPECTION CERTIFICATE

EN 10204 3.1

Number: 428723

Page: 1 / 2

Rev: 0

Date: 06.10.2009

06.10.2009

CUSTOMER : PO : **C02989*** OUR REFERENCE: **K0002**
 STANDARD : **EN 10216-5 TC2**
 ADDIT. SPECS : **NACE MR01.75-03 / NACE MR03-03 / ISO 15156-3**
 GRADE : **1.4301/1.4306**
 DIMENSIONS : **60,32 X 8,74**
 MATERIAL : **SEAMLESS STAINLESS STEEL TUBE**
COLD ROLLED; PICKLED-PASSIVATED;
PLAIN BEVELLED ENDS;

ITEM	HEAT	NO. OF	WEIGHT	TOTAL LENGTH	UNIT LENGTH	
YOUR	TTI.	PIECES	KG			
	66	41544	28	1933	172,52	5,5 - 6,5 MT

RAW MATERIAL

MELTING PROCESS: ELECTRIC FURNACE + A.O.D FROM: ACERALAVA
 PEELED BARS; MACROETCH TESTING: GOOD;

CHEMICAL COMPOSITION (*1 L: LADLE; C: PRODUCT)

*1 HEAT	C	Mn	Si	P	S	Ni	Cr	N
L 41544	0,017	1,50	0,300	0,027	0,0010	10,15	18,30	0,0720

HEAT TREATMENT

SOLUTION ANNEALED 1100 °C HOLDING TIME >=1.5 MIN/MM WATER QUENCHED

TESTS		TENSION				IMPACT TESTS		HARDNESS
NR.	NR.	T(°C)	MPA		%		HRB	
HEAT	TEST		RM	RP 0,2	RP 1,0	A	Z	T(°C) MINIMUM AVERAGE
41544	908135	20	550,0	321,0	369,0	46,7		81 82
41544	908135A	20	550,0	322,0	369,0	45,3		81 82

TECHNOLOGICALS

FLATTENING TEST: GOOD
 RING EXPANDING TEST: GOOD

METALLURGICAL TEST

INTERGRANULAR CORROSION: A262 "E"/ISO 3651-2/ 5 TEST ACC.MIL-P-1144D+24691/3: GOOD

NON DESTRUCTIVE TEST

100 % U.T TO EN10246-7 (ENT.5%, MIN.0,3MM) , GOOD
 100 % EDDY CURRENT TEST AT E-426 , GOOD
 100 % HYDROSTATIC PRESSURE TESTED AT 80 BAR , DURING 5 SEC, GOOD
 STEEL GRADE CHECKING ON EACH TUBE BY SPECTROMETRY (PMI): SATISFACTORY
 DIMENSIONAL CHECKING ON EACH TUBE, SATISFACTORY
 VISUAL INSPECTION ON EACH TUBE, SATISFACTORY



OTHER MATERIAL SPECIFICATIONS

A/SA312M-08A ED.07 + 08 ADD TP304-304L
 A/SA376M-06 ED.07 + 08 ADD TP304

MARKS

TX2
 TUBACEX 60,32 X 8,74 EN 10216-5 TC2 1.4301-1.4306 CFD ASTM-ASME
 A-SA 312 TP304-304L A-SA 376 TP304 SMLS HEAT/..... PMI TX2
 SPAIN

REMARKS

TOL. ISO 1127 D3-T3 / ASTM A999
 NO WELD REPAIR WAS PERFORMED

COPIA CONFORME ALL'ORIGINALE



We hereby certify that the material herein described has been manufactured, sampled, tested and inspected in accordance with above standards and specifications and satisfies the order's requirements.
 This certificate is issued by a computerized system and it is valid without original signature. In case the owner of this certificate would request a copy of it, he must advise its conformity to the issuer, assuming the responsibility for any unlawful or T.T.I.,S.A. not allowed use.
 Any forgery or falsification of this certificate shall legally prosecuted.

T.T.I.
 Tubacex Tubos Inoxidables, S.A.

INGENIERIA DE CALIDAD

JON ARRESE ZUBIZARRETA



T.T.I. - Tubacex Tubos Inoxidables, S.A.

Registro Mercantil de Álava, Tomo 587, Folio 188, Hoja VI 2886 - N.I.F. A-61140227

Printed on:
21.10.2009

INSPECTION CERTIFICATE

EN 10204 3.1

Number: 428723
Page: 2 / 2

Rev: 0

Date: 06.10.2009 06.10.2009

CUSTOMER : PO : **C02989*** OUR REFERENCE: **K0002**

STANDARD : **EN 10216-5 TC2**

ADDIT. SPECS : **NACE MR01.75-03 / NACE MR03-03 / ISO 15156-3**

GRADE : **1.4301/1.4306**

DIMENSIONS : **60,32 X 8,74**

MATERIAL : **SEAMLESS STAINLESS STEEL TUBE**
COLD ROLLED; PICKLED-PASSIVATED;
PLAIN BEVELLED ENDS;

MATERIAL MANUFACTURER APPROVED WITH CERTIFICATE NR. 07/2001/MUC BY TÜV SÜDDEUTSCHLAND (NOTIFIED BODY 0036) TO ISSUE CERTIFICATES OF SPECIFIC PRODUCT CONTROL IN ACCORDANCE WITH PRESSURE EQUIPMENT DIRECTIVE 97/23/EC ANNEX 1 POINT 4.3. MATERIAL CHARACTERISTICS COMPLY WITH POINT 7.5 OF ANNEX I TO PED BY HAVING AN ELONGATION AFTER RUPTURE AT TENSILE TEST NO LESS THAN 14 % AND A BENDING RUPTURE ENERGY AT IMPACT TEST NO LESS THAN 27 J AT 20°C.



We hereby certify that the material herein described has been manufactured, sampled, tested and inspected in accordance with above standards and specifications and satisfies the order's requirements.

This certificate is issued by a computerized system and it is valid without original signature. In case the owner of the certificate would release a copy of it, he must state its conformity to the issued, assuming the responsibility for any unlawful or T.T.I.S.A. not allowed use.

Any forgery or falsification of this certificate shall legally prosecuted.

T.T.I.
Tubacex Tubos Inoxidables, S.A.

INGENIERIA DE CALIDAD

[Signature]
Jon Albano Zubizarreta



R.T.I. S.p.A
SEDE LEGALE E AMMINISTRATIVA
Via Ambrosoli, 2/A
20090 RODANO MILLEPINI (MI)
Tel. +39.02.95328610 c.a. Fax +39.02.95328611
C.F. 00659860191 - P.IVA/V.A.T.(IT) 10003740155

Rodano, 16/04/2010

Oggetto: CERTIFICATI MATERIALI
CARTIFICATE OF MATERIAL

Nostra Commessa: 1/51266
Vostro Num.Ordine: 79-10

Del 29/03/2010
Del 23/03/2010

Con la presente Vi trasmettiamo copia conforme all'originale dei certificati relativi all'ordine sopra menzionato.
Please find enclosed copy of the certificate conforming to the original relevant the above mentioned order.

Spett.le

SIET S.P.A.

VIA NENO BIXIO, 27

Località PIACENZA **CAP** 29100 **Prov.** PC



Saldo/Balance	Acc./Part.delivery
	X

--RIEPILOGO POSEZIONI / SUMMARY POSITIONS--						RIEPILOGO CERTIFICATI / SUMMARY CERTIFICATES		
Vs. Pos.	ARTICOLO / ITEM	DESCRIZIONE / Description	Qtà consegnata / Qty delivered	Vs. Riferimento	Num. bolli di consegna	Colata / Heat	Num. Certificato / Certificate number	Note
	RFW1269003	CURVE 90° LR SCH.80S-304L-D.1/2"	2		B 1/1704 del 12/04/2010	TG090121	128-4	
	RFW1269005	CURVE 90° LR SCH.80S-304L-D.1"	1		B 1/1704 del 12/04/2010	30701-099	91122-7	
	RFW1285192	TEE RID.SCH.80S-304L-D.1"XD.1/2"	1		B 1/1704 del 12/04/2010	2P549	1207011	
	RFW1302218	RID.COINC.SCH.40S-304L-D.3"XD.2"	1		B 1/1704 del 12/04/2010	SLA090320-B	91031-8	
	RFW1302242	RID.COINC.SCH.40S-304L-D.5"XD.3"	1		B 1/1704 del 12/04/2010	08A2316	9114-01	
	RF1252002	GOMITI 90° S.3000 SW-304L-3/8"	2		B 1/1704 del 12/04/2010	075	00696/001	
	RF1254002	TEE S.3000 SW-304L-3/8"	1		B 1/1704 del 12/04/2010	834739	01540/001	
	RF1257208	TEE RID.S.6000 SW-F304L-2X1	1		B 1/1704 del 12/04/2010	H416	00696/001	
	RF1257209	TEE RID.S.6000 SW-F304L-2X1/4	1		B 1/1704 del 12/04/2010	H416	00696/001	
	RF1257210	TEE RID.S.6000 SW-F304L-2X1/2	2		B 1/1704 del 12/04/2010	H416	00696/001	
	RF1345186	SWAGE 80 PE X PE-304L-1/2X3/8	1		B 1/1704 del 12/04/2010	C29	00696/002	
	RF1345193	SWAGE 80 PE X PE-304L-1X3/8	1		B 1/1704 del 12/04/2010	E87	00696/001	

--RIEPILOGO POSIZIONI / SUMMARY POSITIONS--						RIEPILOGO CERTIFICATI / SUMMARY CERTIFICATES		
Vs. Pos.	ARTICOLO / ITEM	DESCRIZIONE / Description	Qtà consegnata / Qty delivered	Vs. Riferimento	Num. bolla di consegna	Colata / Heat	Num. Certificato / Certificate number	Note
	V20100151266089	CURVE 90° LR SCH.180-304L D.2"	3		B 1/1704 del 12/04/2010	TG080059	128-2	
	V20100151266090	MANICOTTI S.3000 GAS CIL-F304L-2"	1		B 1/1704 del 12/04/2010	M463	00696/001	
	V20100151266091	MANIC. S.3000 GAS CIL-F304L-1 1/4"	1		B 1/1704 del 12/04/2010	M476	00696/001	

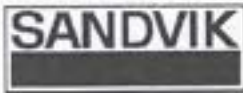

CertificateNo

128-2

1(2)

Date

2010-04-06

Riferimenti del cliente

Indirizzo del cliente

SIG.MARINELLI
R.T.I. SPA
VIA AMBROSOLI 2/A
20090 RODANO MILLEPINI MI
Italy

Codice prodotto Cliente

FBBLR-304L-2-160

Numero d'ordine

ORD.29527/10 29.3

Riferimenti di Sandvik

Codice prodotto Sandvik

FBBLR-304L-2-160

Lunghezza

Lotto

Colata

TG080059

Quantità consegnata

3 Pieces

Numero d'ordine del cliente

255501

Linea d'ordine del cliente

4

DDT Nr

15900



LIXUE GROUP CO.,LTD.

TINGTIAN INDUSTRIAL ZONE, RUIAN CITY, ZHEJIANG CHINA

MILL TEST CERTIFICATE ACCORDING TO EN 10204./3.1+PED 97/23/EC

ISO9001:2000

Client		Santrade Ltd				Certificate No		20100128-2				
Contract NO		GF20091217				Delivery Conditions		Solution Annealed, pickled and passivated				
Product		STAINLESS STEEL COLD FORMED BUTT WELD FITTINGS				Specification		ASTM/ASME A/SA 403-06 ANSI B16.9-07				
Item	Quantity	Size		Description		Grade	Heat No.	Heat treatment	Quenching			
2	300	1"	SCH10S	Long Radius Elbows 90°		WP304/304L-S	00910202	1052° 15 min.	RWQ			
10	20	2"	SCH160	Long Radius Elbows 90°		WP304/304L-S	TG080059	1052° 15 min.	RWQ			
14	100	3/4"	SCH80S	Long Radius Elbows 90°		WP304/304L-S	LH08-4022	1052° 15 min.	RWQ			
15	150	1/2"	SCH10S	Long Radius Elbows 90°		WP316/316L-S	TG080131	1052° 15 min.	RWQ			
17	100	1 1/4"	SCH10S	Long Radius Elbows 90°		WP316/316L-S	YT090227	1052° 15 min.	RWQ			
20	150	3"	SCH40S	Long Radius Elbows 90°		WP316/316L-S	TG090482	1052° 15 min.	RWQ			
23	20	4"	SCH160	Long Radius Elbows 90°		WP316/316L-S	TG090607	1052° 15 min.	RWQ			
chemical composition (%)												
Heat No.	C	Mn	P	S	Si	Cr	Ni	Mo	Ti			
00910202	0.030	1.86	0.033	0.002	0.280	18.30	8.19					
TG080059	0.027	0.82	0.039	0.002	0.540	18.11	8.07					
LH08-4022	0.016	0.85	0.034	0.009	0.52	18.39	8.15					
TG080131	0.025	0.77	0.039	0.001	0.430	18.58	11.06	2.08				
YT090227	0.022	0.78	0.038	0.003	0.380	16.67	10.08	2.08				
TG090482	0.024	0.86	0.040	0.003	0.390	16.70	10.06	2.07				
TG090607	0.021	0.85	0.039	0.002	0.440	16.76	10.09	2.08				
Mechanical Properties					NACE MR0175	IC Test ASTM A262E	Impact Test	Non-destructive Test		PMI	Visual	Dimensional
Heat No.	TS(Mpa)	YS (Mpa)	EL(%)	Hardness				PT				
00910202	534	255	62	HRB<=90	OK	OK	N/A	OK	OK	OK	OK	
TG080059	560	245	60	HRB<=90	OK	OK	N/A	OK	OK	OK	OK	
LH08-4022	615	305	50	HRB<=90	OK	OK	N/A	OK	OK	OK	OK	
TG080131	575	265	60	HRB<=90	OK	OK	N/A	OK	OK	OK	OK	
YT090227	535	225	62	HRB<=90	OK	OK	N/A	OK	OK	OK	OK	
TG090482	575	255	60	HRB<=90	OK	OK	N/A	OK	OK	OK	OK	
TG090607	560	260	57	HRB<=90	OK	OK	N/A	OK	OK	OK	OK	

MARKINGS: LIXUE - SPEC - SIZE - SCH - GRADE - HEAT NO

Materials have been manufactured in complete accordance with the purchasers order

The melting process: Electric arc furnace

PO NO: 24110

Signed:
Date: 2010.01.28

QUALITY ASSURANCE APPROVAL
Q.A. Manager
02. März 2010
SANTRADE LTD LUCERNE



SANTRADE ITALIA S.p.A.
REVIEWED

CHEMICAL ANALYSIS AND MECHANICAL TEST CERTIFICATE TO: DIN 50049 3.1 - EN 10204/3.1

Messrs. R.T.I. SPA VIA AMBROSOLI 2/A 20090 RODANO MILLEPINI MI	ORDER: 29525/10 DATE : 29/03/2010 JOB : 10/91 /00895
---	--



omsa S.R.L.

OFFICINE INGEGNERIE SOLBIATE ARNO

Sede e Stabilimento: 21048 SOLBIATE ARNO (Varese)
Via Caronno Varese
Tel. +39.0331.994.216 - Fax +39.0331.991.798
web: http://www.omsafinding.it - e-mail: info@omsafindings.it



ITEM	Q.TY	DESCRIPTION	MATERIAL	HEAT CODE	STEEL MLL	MLL CERT	HEAT N.
1	1,00	TEE S.6000 2*X3/4" SW F304L	SA182P304/304L	M416	COONE	2009005078	873477
2	2,00	TEE S.6000 2"x1/2" SW F304L	SA182P304/304L	M416	COONE	2009005078	873477
3	1,00	TEE S.6000 2*X1" SW F304L	SA182P304/304L	M416	COONE	2009005078	873477
4	2,00	GOMITO 90 S.3000 3/8" SW F304L	SA182P304/304L	D75	GLARRA	421.058	962852
5	1,00	SWAGE XS 1*X3/8" FBE F304L	SA182P304/304L	E87	COONE	2009037018	972199
6	1,00	MANICOTTO 1000 2" ISO7 RP F304L	SA182P304/304L	M463	ACC. VALBRUNA	HEST780643/2009	247199
7	1,00	MANICOTTO 1000 1.1/4" ISO7 RP F304L	SA182P304/304L	M476	ACC. VALBRUNA	802704/2009	423100

CHEMICAL ANALYSIS

HEAT CODE	C %	Mn %	Si %	P %	S %	Ni %	Cr %	Mo %	Ti %	Al %	V %	Cu %	Nb %	N %	C.E. %	NOTE
M416	0,020	1,290	0,330	0,032	0,030	8,060	18,120	0,430	0,000	0,000	0,000	0,330	0,000	0,077	0,000	0,000
M416	0,020	1,290	0,330	0,032	0,030	8,060	18,120	0,430	0,000	0,000	0,000	0,330	0,000	0,077	0,000	0,000
M416	0,020	1,290	0,330	0,032	0,030	8,060	18,120	0,430	0,000	0,000	0,000	0,330	0,000	0,077	0,000	0,000
D75	0,024	1,550	0,360	0,034	0,027	8,050	18,050	0,000	0,000	0,000	0,000	0,000	0,000	0,083	0,000	0,000
E87	0,024	1,350	0,370	0,032	0,027	8,060	18,080	0,390	0,000	0,000	0,000	0,300	0,000	0,092	0,000	0,000
M463	0,018	1,800	0,630	0,029	0,030	8,220	18,010	0,490	0,000	0,000	0,000	0,470	0,000	0,088	0,000	0,000
M476	0,016	1,770	0,590	0,026	0,025	8,170	18,270	0,430	0,000	0,000	0,000	0,500	0,000	0,088	0,000	0,000

MECHANICAL TEST

HEAT CODE	R N/mm ²	S N/mm ²	A %	C %	Bending Test	Flattenin g	Hydraulic Test	HARDNESS HB	IMPACT TEST J - °C	HEAT TREATMENT - °C	NOTE
M416	607,0	275,0	57,0	74,0				178 178		SOLUTION AT 1050	
M416	607,0	275,0	57,0	74,0				178 178		SOLUTION AT 1050	
M416	607,0	275,0	57,0	74,0				178 178		SOLUTION AT 1050	
D75	623,0	319,0	54,0	73,0				170 170		SOLUTION AT 1050	
E87	613,0	263,0	57,8	74,0				178 178	285 289 290 20	SOLUTION AT 1050	
M463	615,0	308,0	62,0	70,0				181 181		SOLUTION AT 1050	
M476	661,0	399,0	47,0	74,0				190 190	224 229 221 20	SOLUTION AT 1050	

WE HEREBY CERTIFY THAT THE ABOVE IS IN ACCORDANCE WITH THE ORIGINAL CERTIFICATE WHICH IS HELD BY US.
SPECIMEN FOR ELONGATION: STANDARD ROUND. FITTINGS MEET ANSI B16.11 & B31.99 REQUIREMENTS.UNIONS GROUND JOINT, STEEL TO STEEL
FITTINGS ARE DIMENSIONAL AND SURFACE CHECKED WITHOUT OBJECTION. C/SWADES AND PIPE NIPPLES SEAMLESS.
MATERIAL TO ASME Sec.II Part A Ed.2007 - ASTM 01.01 MACE MR01.75 MR01.03 LATEST EDITION. A105N NORMALISED AT 890 C.
IN ACCORDANCE WITH PED 97/23/EC ANNEX 1 SECT. 4.3, WHERE REQUIRED EDY CURRENT OR HYDROSTATIC TEST WITHOUT OBJECTIONS.
ASTM A182 F11 NORM. AT 920 C. O'LET TO MSS SP97.

INSPECTION	O.M.S.A. S.R.L. Quality Assurance Manager (Davide Foschini) <i>Davide Foschini</i>	CERTIFICATE N° 00494/001	DATE 08/04/2010
------------	---	-----------------------------	--------------------



T.T.I. - Tubacex Tubos Inoxidables, S.A.

Registro Mercantil de Alava, Tomo 587, Folio 100, Hoja VI 2885 - N.I.F. A-01140227

Printed on:
26.06.2009

INSPECTION CERTIFICATE	Number: 425772 Page: 1 / 2	Rev: 0
EN 10204 3.1	Date: 26.06.2009	26.06.2009

CUSTOMER :	PO : 216-6/2/09	OUR REFERENCE: K0146
STANDARD :	ASME 2001 PART.A SEC.II A/SA312 ED.07 AD-2000 W2 2003 "EINBAUROHRE"	
ADDIT. SPECS :	DOC.NO. MTS-PS-001 AND NACE MR01.75-03/ISO 15156-3	
GRADE :	TP304/304L	
DIMENSIONS :	33,4 X 4,55	
MATERIAL :	SEAMLESS STAINLESS STEEL TUBE COLD ROLLED; PICKLED-PASSIVATED; FLAIN ENDS SQUARE CUT;	



---ITEM---	---HEAT---	NO. OF	---WEIGHT---	---TOTAL LENGTH---	---UNIT LENGTH---	
YOUR	TTI.	PIECES	KG			
	9	41659	40	912	276,96	6 - 7,5 MT

RAW MATERIAL

MELTING PROCESS: ELECTRIC FURNACE + A.O.D FROM: ACERALAVA
PEELED BARS; MACROETCH TESTING: GOOD;

CHEMICAL COMPOSITION (% I: LABEL; C: PRODUCT)

*I HEAT	C	Mn	Si	P	S	Ni	Cr	Mo	Al	Cu	V	Ti
L 41659	0,014	1,48	0,340	0,028	0,0010	10,20	18,25	0,59	0,006	0,35	0,045	0,006
	Nb	S	W	Co	Ca	N						
L 41659	0,026	0,0011	0,020	0,065	0,0013	0,0700						

HEAT TREATMENT

SOLUTION ANNEALED 1100 °C HOLDING TIME >=1,5 MIN/MM WATER QUENCHED

= TESTS =	NR.	T(°C)	-----TENSION-----			---I M P A C T T E S T S---			HARDNESS	
			MPA	%	%	T(°C)	MINIMUM	AVERAGE	HRB	
HEAT	TEST		RM	RP 0,2	RP 1,0	A	Z			
41659	905365	20	573,0	270,0	317,0	56,0			86	87
41659	905365A	20	570,0	273,0	329,0	56,9			87	87

TECHNOLOGICALS

FLATTENING TEST: GOOD
RING EXPANDING TEST: GOOD

METALLURGICAL TEST

INTERGRANULAR CORROSION: A-262 PRACT."E", ISO 3651-2: NOT OBJECTIONS

NON DESTRUCTIVE TEST

100 % EDDY CURRENT TEST AT E.426 , GOOD
STEEL GRADE CHECKING ON EACH TUBE BY SPECTROMETRY (PMI): SATISFACTORY
DIMENSIONAL CHECKING ON EACH TUBE, SATISFACTORY
VISUAL INSPECTION ON EACH TUBE, SATISFACTORY

OTHER MATERIAL SPECIFICATIONS

EN 10216-5 TC1 X5CRNI18-10 WN. 1.4301
EN 10216-5 TC1 X2CRNI18-9 WN. 1.4307



MARKS

TX2
TUBACEX 33,4 X 4,55 EN 10216-5 TC1 X5CRNI18-10 WN 1.4301 /
X2CRNI18-9 WN 1.4307 CFD - ASTM-ASME A-SA 312 TP304-304L SMLS
HEAT/..... NH ET PMI TX2
TOL. EN ISO 1127 D3/T3.

REMARKS

T.T.I GARANTIT QUE TOUS LES TUBES LIVRES SONT CONFORMES AUX SPEC.S DE L'ARTICLE 15 DE L'ARRETE MINISTERIEL DU 24 MARS 1978 MODIFIE

COPIA CONTINERE ALL'ORIGINALI
TUBACEX S.R.L.

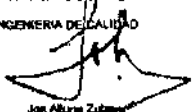
 <small>Entidad Registrada</small> <small>EN-006/1998</small>		 <small>Certificación Ambiental</small> <small>00M04/98</small>	<p>We hereby certify that the material herein described has been manufactured, sampled, tested and inspected in accordance with above standards and specifications and satisfies the order's requirements.</p> <p>This certificate is issued by a computerized system and it is valid without original signature. In case the owner of this certificate would release a copy of it he must accept its conformity to the issued, assuming the responsibility for any violation or T.T.I.S.A. not allowed use.</p> <p>Any forgery or falsification of this certificate shall legally prosecuted.</p>	<p style="font-size: small;">T.T.I. Tubacex Tubos Inoxidables, S.A. INGENIERIA DE CALIDAD</p>  <small>Jon Alkorta Zubizarreta</small>
--	---	--	--	---



T.T.I. - Tubacex Tubos Inoxidables, S.A.

Registro Mercantil de Aleva, Tomo 587, Folio 188, Hoja VI 2886 - N.I.F. A-81140227

Printed on:
26.06.2009

INSPECTION CERTIFICATE

EN 10204 3.1

Number: 425772
Page: 2 / 2

Rev: 0

Date: 26.06.2009 26.06.2009

CUSTOMER : PO : 216-6/2/09 OUR REFERENCE: K0146
 STANDARD : ASME 2001 PART.A SEC.II A/SA312 ED.07 AD-2000 W2 2003 "EINBAUROHRE"
 ADDIT. SPECS : DOC.NO. MTS-PS-001 AND NACE MR01.75-03/ISO 15156-3
 GRADE : TP304/304L
 DIMENSIONS : 33,4 X 4,55
 MATERIAL : SEAMLESS STAINLESS STEEL TUBE
 COLD ROLLED; PICKLED-PASSIVATED;
 PLAIN ENDS SQUARE CUT;

C<=0,25%, P<=0,05%, S<=0,05%, R<800 N/MM2, E<=0,9 * R
 A% (LO=5,65VSO) MIN, 16% EN LONG. R(A 2)>=10500
 MATERIAL MANUFACTURER APPROVED WITH CERTIFICATE NR. 07/2001/MUC BY TÜV SÜDDEUTSCHLAND
 (NOTIFIED BODY 0036) TO ISSUE CERTIFICATES OF SPECIFIC PRODUCT CONTROL IN
 ACCORDANCE WITH PRESSURE EQUIPMENT DIRECTIVE 97/23/EC ANNEX 1 POINT 4.3.
 MATERIAL CHARACTERISTICS COMPLY WITH POINT 7.5 OF ANNEX I TO PED BY HAVING AN ELONGATION
 AFTER RUPTURE AT TENSILE TEST NO LESS THAN 14 % AND A BENDING RUPTURE ENERGY AT IMPACT TE
 ST NO LESS THAN 27 J AT 20°C.



We hereby certify that the material herein described has been manufactured, sampled, tested and inspected in accordance with above standards and specifications and satisfies the order's requirements.
 This certificate is issued by a computerized system and it is valid without original signature.
 In case the owner of the certificate would release a copy of it, he must stand its conformity to the issued, assuming the responsibility for any misuse or T.T.I.S.A. not allowed use.
 Any forgery or falsification of this certificate shall legally prosecuted.

T.T.I.
Tubacex Tubos Inoxidables, S.A.

INGENIERIA DE CALIDAD

[Handwritten signature]
Jon Atxaga Zubizarreta

ER-0006/1991

COM-01137

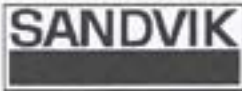

CertificateNo
1207011

1(2)

Date
2010-04-06

Riferimenti del cliente

Indirizzo del cliente

SIG.MARINELLI
R.T.I. SPA
VIA AMBROSOLI 2/A
20090 RODANO MILLEPINI MI
Italy

Codice prodotto Cliente

FBRT-304L-1-1/2-80S

Numero d'ordine

ORD.29527/10 29.3

Riferimenti di Sandvik

Codice prodotto Sandvik

FBRT-304L-1-1/2-80S

Lunghezza

Lotto

Colata

2P549

Quantità consegnata

1 Pieces

Numero d'ordine del cliente

255501

Linea d'ordine del cliente

7

DDT Nr

15900



Zhejiang Yuli Pipeline Industry Co., Ltd.

Mill Test Certificate

BAJIA INDUSTRIAL ZONE SHACHENG TOWN, LONGWAN DISTRICT, WENZHOU, ZHEJIANG, CHINA

Certificate: EN10204/3.1 Certificate-NO: MC-TYF-5-20091207011 Page 11 of 16

Customer:	Santrade Steel Ltd	Marking: • Manufacture's Mark • Dimension & Schedule • Material S(Seamless)orW(Welded) • Heat Number & Standard
Order No.:	22962	
Description:	Seamless stainless steel BW fittings	
Specification:	ANSI B16.9	
Material:	ASTM A403/ASME SA403-WPS-304/304L	
Workmanship:	Cold forming	
Heat Treatment:	Solution annealing and quenched	

Extend of material delivery:

Item No.	Description	Dimension	Quantity	Heat No.	Base Cert.No.	Remarks
1	RED TEE	1"*80S*1/2"*80S	20	2P549	200909067276005	
2						
3						
4						
5						

Inspection Results (The requirements are fulfilled as listed in Annex):

A. Chemical Analysis:

Heat No.	C%	Mn%	Si%	S%	P%	Cr%	Ni%	Mo%	Cu%	Ti%
1	2P549	0.014	1.12	0.41	0.001	0.030	18.04	8.05		
2										
3										
4										
5										

B. Mechanical Properties & Tensile Inspection :

Heat No.	Yield Strength		Tensile Strength	Elongation	Hardness	Charpy Impact	
	0.2%	1%					
1	2P549	265	590	57	OK		
2							
3							
4							
5							

C. Inspection and Related Data Verify:

Dimensional check	OK	Hydrostatic pressure test	/
Surface quality inspection	OK	Radiography Examination	/
Penetration examination	OK	IC to ASTM A262 "E"	OK
PMI	OK	HT to NACE MR-0175	OK

D. Remarks:

QUALITY ASSURANCE APPROVAL
 21. Jan. 2010
 SANTRADE LTD LUCERNE

Work inspector:

良吳
 印軍



SANDVIK ITALIA S.p.A.
REVIEWED

Date

2010-04-06

Riferimenti del cliente**Indirizzo del cliente**

SIG.MARINELLI
R.T.I. SPA
VIA AMBROSOLI 2/A
20090 RODANO MILLEPINI MI
Italy

Codice prodotto Cliente

FBBLR-304L-1-80S

Numero d'ordine

ORD.29527/10 29.3

Riferimenti di Sandvik**Codice prodotto Sandvik**

FBBLR-304L-1-80S

Lunghezza**Lotto****Colata**

J0701-099

Quantità consegnata

1 Pieces

Numero d'ordine del cliente

255501

Linea d'ordine del cliente

3

DDT Nr

15900



LIXUE STEEL PIPE CO.,LTD.

TINGTIAN INDUSTRIAL ZONE RUIAN CITY, ZHEJIANG, CHINA

MILL TEST CERTIFICATE IN ACC. WITH EN 10204 3.1 ISO9001:2000+PED97/23/EC+AD2000

Client		Santrade Ltd		Certificate No		091122-7					
Contract NO		GF20091106		Delivery Conditions		Solution Annealed, pickled and passivated					
Product		STAINLESS STEEL COLD FORMED BUTT WELD FITTINGS		Specification		ASTM/ASME A/SA 403-06 ANSI B16.9-07					
Item	Quantity	Size	Description	Grade	Heat No.	Heat treatment	Quenching				
52	50	2"X1 1/2" SCH10S	Concentric Reducers	WP316/316L-S	B189	1052* 15 min.	RWQ				
53	10	2"X1 1/2" SCH40S	Concentric Reducers	WP316/316L-S	YT082283	1052* 15 min.	RWQ				
55	20	3"X2" SCH40S	Concentric Reducers	WP316/316L-S	TG090191	1052* 15 min.	RWQ				
56	20	3"X2 1/2" SCH10S	Concentric Reducers	WP316/316L-S	YT080403	1052* 15 min.	RWQ				
57	3	8"X5" SCH10S	Concentric Reducers	WP316/316L-S	YD08-026	1052* 15 min.	RWQ				
58	50	2" SCH80S	Equal Tees	WP316/316L-S	TG080335	1052* 15 min.	RWQ				
60	25	1" SCH80S	Long Radius Elbows 90°	WP304/304L-S	J0701-099	1052* 15 min.	RWQ				
chemical composition (%)											
Heat No.	C	Mn	P	S	Si	Cr	Ni	Mo	Ti		
B189	0.024	0.93	0.041	0.002	0.44	16.42	10.22	2.08			
YT082283	0.021	0.87	0.038	0.003	0.330	16.70	11.08	2.09			
TG090191	0.023	0.81	0.040	0.003	0.350	16.64	11.10	2.07			
YT080403	0.020	0.86	0.040	0.001	0.40	16.62	11.10	2.06			
YD08-026	0.022	0.80	0.039	0.005	0.36	16.60	10.10	2.04			
TG080335	0.020	0.81	0.039	0.001	0.380	16.74	11.08	2.07			
J0701-099	0.022	0.85	0.033	0.001	0.39	18.23	8.10				
Mechanical Properties					NACE MR0175	IC Test ASTM A262E	Impact Test	Non-destructive Test	PMI	Visual	Dimensional
Heat No.	TS(Mpa)	YS (Mpa)	EL(%)	Hardness				PT			
B189	570	250	65	HRB≤90	OK	OK	N/A	OK	OK	OK	OK
YT082283	550	240	58	HRB≤90	OK	OK	N/A	OK	OK	OK	OK
TG090191	565	265	58	HRB≤90	OK	OK	N/A	OK	OK	OK	OK
YT080403	535	225	58	HRB≤90	OK	OK	N/A	OK	OK	OK	OK
YD08-026	570	325	75	HRB≤90	OK	OK	N/A	OK	OK	OK	OK
TG080335	565	275	64	HRB≤90	OK	OK	N/A	OK	OK	OK	OK
J0701-099	580	275	64	HRB≤90	OK	OK	N/A	OK	OK	OK	OK

MARKINGS: LIXUE - SPEC - SIZE - SCH - GRADE - HEAT NO

Materials have been manufactured in complete accordance with the purchase order

QUALITY ASSURANCE APPROVAL

16. Dez. 2009

Signed: [Signature]
Date: 2009.11.22

Q.A. Manager



SANDVIK TALIA S.p.A.
REVIEWED

SANTRADE LTD LOGO

PR NR 24052



T.T.I. - Tubacex Tubos Inoxidables, S.A.

Registro Mercantil de Ajaiz, Tomo 067, Folio 188, Hoja VI 2005 - N.I.F. A-01140227

Printed on:
21.10.2009

INSPECTION CERTIFICATE

EN 10204 3.1

Number: 428715
Page: 1 / 2

Rev: 0

Date: 06.10.2009 06.10.2009

CUSTOMER : PO :C02989* OUR REFERENCE:K0002
 STANDARD :EN 10216-5 TC2 AD-2000 W2/W10/TRD100 "EINBAUHOE"
 ADDIT.SPECS :NACE MR01.75-03 / NACE MR03-03 / ISO 15156-3
 GRADE :1.4301/1.4306
 DIMENSIONS :21,34 X 2,77
 MATERIAL :SEAMLESS STAINLESS STEEL TUBE
 COLD ROLLED; PICKLED-PASSIVATED;
 PLAIN ENDS SQUARE CUT;

ITEM YOUR	HEAT TTI.	NO. OF PIECES	WEIGHT KG	TOTAL LENGTH	UNIT LENGTH
	5	41431	437	3438	2.664,29
					5,5 - 6,5 MT

RAW MATERIAL

MELTING PROCESS: ELECTRIC FURNACE + A.O.D FROM: ACERALAVA
 PEELED BARS; MACROETCH TESTING: GOOD;

CHEMICAL COMPOSITION (*1 L: LADLE; C: PRODUCT)

*1 HEAT	C	Mn	Si	P	S	Ni	Cr	N
L 41431	0,018	1,44	0,270	0,032	0,0010	10,30	18,20	0,0715

HEAT TREATMENT

SOLUTION ANNEALED 1100 °C HOLDING TIME >=1.5 MIN/MM WATER QUENCHED

TESTS NR.	HEAT TEST	T(°C)	TENSION			IMPACT TESTS		HARDNESS		
			RM	RP 0,2	RP 1,0	A	Z	T(°C) MINIMUM	AVERAGE	HRB
41431	908465	20	588,0	305,0	356,0	52,1			84	85
41431	908465A	20	572,0	296,0	346,0	48,6			84	85

TECHNOLOGICALS

FLATTENING TEST: GOOD
 RING EXPANDING TEST: GOOD



METALLURGICAL TEST

INTERGRANULAR CORROSION: A262 "E"/ISO 3651-2/ 5 TEST ACC.MIL-P-1144D+24691/3: GOOD

NON DESTRUCTIVE TEST

100 % EDDY CURRENT TEST AT E-426 , GOOD
 100 % HYDROSTATIC PRESSURE TESTED AT 80 BAR , DURING 5 SEC, GOOD
 STEEL GRADE CHECKING ON EACH TUBE BY SPECTROMETRY (PMI): SATISFACTORY
 DIMENSIONAL CHECKING ON EACH TUBE, SATISFACTORY
 VISUAL INSPECTION ON EACH TUBE, SATISFACTORY

OTHER MATERIAL SPECIFICATIONS

A/SA312M-08A ED.07 + 08 ADD TP304-304L
 A/SA376M-06 ED.07 + 08 ADD TP304

MARKS

TX2
 TUBACEX 21,34 X 2,77 EN 10216-5 TC2 1.4301-1.4306 CFD ASTM-ASME
 A-SA 312 TP304-304L A-SA 376 TP304 SMLS HEAT/..... PMI TX2
 SPAIN

REMARKS

TOL. ISO 1127 D3-T3 / ASTM A999

NO WELD REPAIR WAS PERFORMED

MATERIAL MANUFACTURED APPROVED WITH CERTIFICATE NR. 07/2001/MUC BY TÜV SÜDDEUTSCHLAND



We hereby certify that the material herein described has been manufactured, sampled, tested and inspected in accordance with above standards and specifications and satisfies the order's requirements.
 This certificate is issued by a computerized system and it is valid without original signature. In case the owner of the certificate would release a copy of it, he must attest its conformity to the issued, assuming the responsibility for any unlawful or T.T.I.S.A. not allowed use.
 Any forgery or falsification of this certificate shall be legally prosecuted.

T.T.I.
 Tubacex Tubos Inoxidables, S.A.

INGENIERO DE CALIDAD

[Signature]
 Jon Alana Zubizarreta



T.T.I. - Tubacex Tubos Inoxidables, S.A.

Registro Mercantil de Alava, Tomo 687, Folio 188, Hoja VI 2886 - N.I.F. A-01140227

Printed on:
21.10.2009

INSPECTION CERTIFICATE

EN 10204 3.1

Number: 428715
Page: 2 / 2

Rev: 0

Date: 06.10.2009

06.10.2009

CUSTOMER : PO : C02989* OUR REFERENCE: K0002
 STANDARD : EN 10216-5 TC2 AD-2000 W2/W10/TRD100 "EINBAURHORE"
 ADDIT. SPECS : NACE MR01.75-03 / NACE MR03-03 / ISO 15156-3
 GRADE : 1.4301/1.4306
 DIMENSIONS : 21,34 X 2,77
 MATERIAL : SEAMLESS STAINLESS STEEL TUBE
 COLD ROLLED; PICKLED-PASSIVATED;
 PLAIN ENDS SQUARE CUT;

(NOTIFIED BODY 0036) TO ISSUE CERTIFICATES OF SPECIFIC PRODUCT CONTROL IN ACCORDANCE WITH PRESSURE EQUIPMENT DIRECTIVE 97/23/EC ANNEX 1 POINT 4.3. AS PER LETTER DATED 21.08.92 TÜV SÜDWEST DECLINES COUNTERSIGNING MATERIAL CHARACTERISTICS COMPLY WITH POINT 7.5 OF ANNEX I TO PED BY HAVING AN ELONGATION AFTER RUPTURE AT TENSILE TEST NO LESS THAN 14 % AND A BENDING RUPTURE ENERGY AT IMPACT TEST NO LESS THAN 27 J AT 20°C.

COPIA CONFORME ALL'ORIGINALE
RUBIVAL INOX S.R.L.



We hereby certify that the material herein described has been manufactured, sampled, tested and inspected in accordance with above standards and specifications and satisfies the order's requirements.
 This certificate is issued by a computerized system and it is valid without original signature.
 In case the owner of the certificate would release a copy of it, he must accept its conformity to the issued, assuming the responsibility for any unlawful or T.T.I. S.A. not allowed use.
 Any forgery or falsification of this certificate shall legally prosecuted.

T.T.I.
 Tubacex Tubos Inoxidables, S.A.

INGENIERIA DE CALIDAD



Jon Alvaro Zubizarreta

Allegato 4:

Lista materiali certificati: Disegno 074-00-01rev3 tav. 4, tratto discendente

Assieme

IMPIANTO PROVA BARRE

N°Riferimento Disegno

074.00.01

Rev.:

3

Tav. 4 rev .2

Data:

13/06/2010

Part. N°	Descrizione	Quantità	Lunghezza (mm)	Materiale	N° Certificato	Data Certificato	Fabbricante	N°di colata	Note
33a	Flangia WN 3/4" ansi 2500 LM	1	-	ASTM A182 F304	53/10-1	29/04/'10	Steeltrade	291450	
38/1	Riduzione concentrica 3/4"x1" 1/2 sch. 160	1	-	ASTM WP304	53/10-1	29/04/'10	Steeltrade	906007	
38/2	Riduzione concentrica 2" 1/2 x1" 1/2 sch. 160	1	-	ASTM WP304	53/10-1	29/04/'10	Steeltrade	906007	
38/3	Tubo 2" 1/2 sch.160	1	4429	ASTM AISI 304	2006/1526	04/10/'06	Nikopol Stainless Tube	913044	
38/4	Riduzione concentrica 2" 1/2 x1" sch. 160	1	-	ASTM WP304	53/10-1	29/04/'10	Steeltrade	906007	
38/5	Tubo 1" sch.80	1	462	ASTM AISI 304	425772	26/06/'09	T.T.I. Tubacex	41659	
38/6	Curva 90°LR 1" sch.80	1	-	ASTM WP304	091122-7	22/ 11/'09	LIXUE Group	J0701-099	
38/7	Tubo 1" sch.80	1	150	ASTM AISI 304	425772	26/06/'09	T.T.I. Tubacex	41659	
38/8	Tubo 1/2" sch.80	1	125	ASTM AISI 304	417490	19/12/'08	T.T.I. Tubacex	40405	
42	Tubo 1" sch.80	1	190.5	ASTM AISI 304	425772	26/06/'09	T.T.I. Tubacex	41659	
43b	Flangia WN 1" ansi 2500 LF	2	-	ASTM A182 F304	53/10-1	29/04/'10	Steeltrade	508471	

Compilato da:



Data:

21/06/2010

CERTIFICATE OF CHEMICAL ANALYSIS AND MECHANICAL TEST.



STEELTRADE s.r.l.
 Loc. CATTAGNINA
 29010 ROTTOFRENO (PC) - ITALY
 TEL. +39 0523 780121
 FAX +39 0523 780123
 E-mail: inspection@steeltrade.it
 WEB: http://www.steeltrade.it

CERTIFICATE N. :53/10-1
 DATED :29/04/10

PURCHASER : SIET

YOUR ORDER : 74-10

JOB N. : ST 53/10

ITEM	Q.TY N°	DESCRIPTION	MATERIAL	HEAT CODE	HEAT
ITEM 01	4	WN FLANGE 1" LARGE MALE SCH.80 ANSI 2500	ASTM A182 F304	0B3	374150
ITEM 02	6	WN FLANGE 1" LARGE FEMALE SCH.80 ANSI 2500	ASTM A182 F304	B540	508471
ITEM 03	1	SLIP ON FLANGE 3" RF CL150	ASTM A182 F304	B248	259170
ITEM 04	1	SLIP ON FLANGE 2" RF CL150	ASTM A182 F304	B140	21728
ITEM 05	1	BLIND FLANGE 3" RF CL600 FORATA DIAM. 61 mm	ASTM A182 F304	B254	444625
ITEM 06	1	BLIND FLANGE 2" RF CL150 FORATA DIAM. 34 mm	ASTM A182 F304	B266	D82126A
ITEM 07	8	WN FLANGE 2" LARGE MALE SCH.160 ANSI 2500	ASTM A182 F304	B500	379250
ITEM 08	9	WN FLANGE 2" LARGE FEMALE SCH.160 ANSI 2500	ASTM A182 F304	B500	379250
ITEM 09	1	WN FLANGE 3/4" LARGE MALE SCH.160 ANSI 2500	ASTM A182 F304	B273	291450
ITEM 10	1	WN FLANGE 3/4" LARGE FEMALE SCH.160 ANSI 2500	ASTM A182 F304	B273	291450

Chemical Analysis

HEAT	C%	Mn%	Si%	P%	S%	Mo%	Cr%	Ni%	V%	Cu%	Ti%	Nb%	C.eq% *
374150	0.023	1.78	0.35	0.0028	0.0021		18.43	8.91					
508471	0.009	1.12	0.40	0.028	0.0026		18.14	9.12					
259170	0.014	1.75	0.31	0.026	0.024		18.33	8.14					
21728	0.017	0.77	0.32	0.028	0.002		18.25	9.20					
444625	0.013	1.10	0.41	0.026	0.026		18.20	9.22					
D82126A	0.019	1.61	0.42	0.025	0.025		18.26	10.17					
379250	0.022	1.71	0.24	0.03	0.021		18.22	8.93					
291450	0.022	1.76	0.31	0.029	0.026		18.32	8.20					

Mechanical Properties

HEAT	TENSILE TEST					IMPACT TEST					
	Tensile strength N/mm2	Yield point N/mm2	Elongation 2" %	Red. of Area %	Hardness HB	Type	Section	Temp.	Values J	Values J	Values J
374150	606	341	47.2	60.3							
508471	549	348	52.6	74.8							
259170	582	241	61.0	70.4							
21728	525	375	49.0	73.0							
444625	577	278	57.0	69.0							
D82126A	576	242	53.0	71.0							
379250	576	281	57.0	72.6							
291450	580	274	59.7	75.0							

NOTE:

- CERTIFICATE CONFORM TO : EN 10204.3.1
- STEEL MADE BY ELECTRIC FURNACE
- HEAT TREATMENT : SOLUTION ANNEALED
- ACCORDING TO PED 97/23/EC ANNEX 1 PAR.4.3
- PMI : NO OBJECTION (100% TESTED WITH NITON ANALYZER)
- DIMENSIONS : ASME B16.5
- VISUAL AND DIMENSIONAL TEST : SATISFACTORY

Quality Control
STEELTRADE



*C. eq. by long formula

The present certificate is in fully accordance with UNI CEI EN 45014-90

CERTIFICATE OF CHEMICAL ANALYSIS AND MECHANICAL TEST .



STEELTRADE s.r.l.
 Loc. CATTAGNINA
 29010 ROTTOFRENO (PC) - ITALY
 TEL. +39 0523 780121
 FAX +39 0523 780123
 E-mail: inspection@steeltrade.it
 WEB: http://www.steeltrade.it

CERTIFICATE N. :53/10-2
DATED :30/04/10

PURCHASER : SIET

YOUR ORDER : 74-10

JOB N. : ST 53/10

ITEM	Q.TY N°	DESCRIPTION	MATERIAL	HEAT CODE	HEAT
ITEM 11	1	BW CONC. REDUCER 1 1/2" x 3/4" SCH.160 x SCH.160	ASTM A403 WP304		906007
ITEM 12	1	BW CONC. REDUCER 2 1/2" x 1 1/2" SCH.160 x SCH.160	ASTM A403 WP304		906007
ITEM 13	1	BW CONC. REDUCER 2 1/2" x 1" SCH.160 x SCH.160	ASTM A403 WP304		906007

Chemical Analysis

HEAT	C%	Mn%	Si%	P%	S%	Mo%	Cr%	Ni%	V%	Cu%	Ti%	Nb%	C.eq% *
906007	0.024	1.08	0.45	0.032	0.022		18.10	8.05					

Mechanical Properties

HEAT	TENSILE TEST				Hardness HB	IMPACT TEST							
	Tensile strenght N/mm2	Yield point N/mm2	Elongation 2" %	Red. of Area %		Type	Section	Temp.	Values J	Values J	Values J		
906007	562	277	66.0										

NOTE:

- CERTIFICATE CONFORM TO : EN 10204.3.1
- STEEL MADE BY ELECTRIC FURNACE
- HEAT TREATMENT : SOLUTION ANNEALED
- ACCORDING TO PED 97/23/EC ANNEX 1 PAR.4.3
- PMI : NO OBJECTION (100% TESTED WITH NITON ANALYZER)
- DIMENSIONS : ASME B16.9
- VISUAL AND DIMENSIONAL TEST : SATISFACTORY

Quality Control
STEELTRADE



*C. eq. by long formula

The present certificate is in fully accordance with UNI CEI EN 45014-90





Ukraine

Nikopol Stainless Tube Mill

53201 56, Trubnikov Avenue Nikopol Dnepropetrovsk Region Ukraine tel/fax (05662) 2-51-94

Требования Сертификата Inspection Certificate EN 10204 3.1	Сертификат приемочных испытаний № Material Test Certificate No. 2006/1526	Лист/Page 1	Листов/Pages 2
Заказчик Customer			
Страна назначения Country of destination			
Адрес Address			
Контракт №/Contract No.	1483		

ТЕХНИЧЕСКИЕ ТРЕБОВАНИЯ / TECHNICAL REQUIREMENTS

Наименование продукции/Product description

SEAMLESS STAINLESS STEEL HOT ROLLED TUBES

НТД/Specification ASTM/ASME: A-SA 312-04b; ASTM: A-999/999M-01; NFA 49-117,
NACE MR 01.75-00

Способ выплавки/Melting process	EAF + AOD	Маркировка/Marking	NSTM
---------------------------------	-----------	--------------------	------

Состояние поставки / State of delivery
passivated

штамп контролера / Inspector's stamp

Сортамент / Range of sizes							Гидроис- пытания/ Hydr. test MPa (t=10sec.)
номер партии, Lot	марка стали/ Steel grade	плавка/ HeatNo.	штук/ Pieces	Метраж/ Total Length, m	вес нетто, кг Net weight, kg	размеры/Dimensions, mm	
695	TP304/304L/ TUZ 2CN 18 10	913044	10	67,5	1004	OD73,03 x 9,52 WT x 5000-7000	OK
695	TP304/304L/ TUZ 2CN 18 10	913044	11	74,3	1102	OD73,03 x 9,52 WT x 5000-7000	OK
695	TP304/304L/ TUZ 2CN 18 10	913044	12	79,3	1174	OD73,03 x 9,52 WT x 5000-7000	OK
TOTAL:			33	221,1	3280		



COPIA CONFORME ALL'ORIGINALE
RUBIVAL INOX S.R.L.

дата / date 04.10.2006

эксперт/inspector

ЭИ В.Куropyatnik
[Signature]

Требования Сертификата Inspection Certificate EN 10204 3.1	Сертификат приемочных испытаний № Material Test Certificate No. 2006/ 1526	Лист/Page 2	Листов/Pages 1
--	---	----------------	-------------------

плавка № Heat No.	C	Mn	Si	P	S	Cr	Ni	Mo	B	
913044	0,024	1,15	0,37	0,040	0,023	18,69	10,35	-	0,0011	

РЕЗУЛЬТАТЫ ИСПЫТАНИЙ / TEST RESULTS

МЕХАНИЧЕСКИЕ ИСПЫТАНИЯ / MECHANICAL TESTS ACC. TO EN 10002-1,-5

партия/ Lot No.	Плавка/ Heat No.	№ образца испытаний Specimen No.	направление испытаний/ Test direction	температура-испытаний/ Test temperature, °C	предел текучести/ Yield strength, МПа	прочность при растяжении Tensile strength, МПа	удлинение Elongation %	ударная вязкость/ Impact strength, J/sm ²	твердость/ Brinell Hardness, HRB
695	913044	1	longitudinal, width	20°	322	578	53		85
		2			320	585	51		87
695	913044	1	gage length 12,5 mm		322	578	53		85
		2			320	585	51		87
695	913044	1			322	578	53		85
		2			320	585	51		87

РЕЗУЛЬТАТЫ МИКРОСТРУКТУРЫ/
MICROSTRUCTURE RESULTS n/a.

ТЕХНОЛОГИЧЕСКИЕ ИСПЫТАНИЯ/
TECHNOLOGICAL TESTS flattening – 1 – 2 stage – acceptable.

ИСПЫТАНИЯ НА МЕЖКРИСТАЛЛИТНУЮ КОРРОЗИЮ/
INTERGRANULAR CORROSION TEST ASTM A 262 , Practice E -acceptable

ИСПЫТАНИЕ НА СООТВЕТСТВИЕ МАРКИ СТАЛИ
POSITIVE MATERIAL IDENTIFICATION - satisfactory.

НЕРАЗРУШАЮЩИЙ КОНТРОЛЬ/
NON-DESTRUCTIVE TEST METHOD 100% hydro-tested – acceptable.

ПРИМЕЧАНИЯ
ADDITIONAL REMARKS Tubes are heat treated : 1080°C holding time 5 minutes then quenched by water.

100% ВИЗУАЛЬНЫЙ КОНТРОЛЬ, ПРОВЕРКА РАЗМЕРОВ/
VISUAL INSPECTION, DIMENSIONAL MEASUREMENT - SATISFACTORY

дата / date **04.10.2006**

эксперт/inspector

ЭИ У.Куропятник



T.T.I. - Tubacex Tubos Inoxidables, S.A.

Registro Mercantil de Alava, Tomo 587, Folio 100, Hoja VI 2885 - N.I.F. A-01140227

Printed on:
26.06.2009

INSPECTION CERTIFICATE	Number: 425772	Rev: 0
EN 10204 3.1	Page: 1 / 2	
	Date: 26.06.2009	26.06.2009

CUSTOMER :	PO : 216-6/2/09	OUR REFERENCE: K0146
STANDARD :	ASME 2001 PART.A SEC.II A/SA312 ED.07 AD-2000 W2 2003 "EINBAUROHRE"	
ADDIT. SPECS :	DOC.NO. MTS-PS-001 AND NACE MR01.75-03/ISO 15156-3	
GRADE :	TP304/304L	
DIMENSIONS :	33,4 X 4,55	
MATERIAL :	SEAMLESS STAINLESS STEEL TUBE COLD ROLLED; PICKLED-PASSIVATED; FLAIN ENDS SQUARE CUT;	



---ITEM---	-HEAT-	NO. OF	---WEIGHT---	-TOTAL LENGTH-	--UNIT LENGTH--
YOUR	TTI.	PIECES	KG		
	9 41659	40	912	276,96	6 - 7,5 MT

RAW MATERIAL

MELTING PROCESS: ELECTRIC FURNACE + A.O.D FROM: ACERALAVA
PEELED BARS; MACROETCH TESTING: GOOD;

CHEMICAL COMPOSITION (% I: LABEL; C: PRODUCT)

*I HEAT	C	Mn	Si	P	S	Ni	Cr	Mo	Al	Cu	V	Ti
L 41659	0,014	1,48	0,340	0,028	0,0010	10,20	18,25	0,59	0,006	0,35	0,045	0,006
	Nb	B	W	Co	Ca	N						
L 41659	0,026	0,0011	0,020	0,065	0,0013	0,0700						

HEAT TREATMENT

SOLUTION ANNEALED 1100 °C HOLDING TIME >=1.5 MIN/MM WATER QUENCHED

= TESTS =	NR.	T(°C)	-----TENSION-----			--I M P A C T T E S T S--			HARDNESS	
			MPA	%	%	T(°C)	MINIMUM	AVERAGE	HRB	
HEAT	TEST		RM	RP 0,2	RP 1,0	A	Z			
41659	905365	20	573,0	270,0	317,0	56,0			86	87
41659	905365A	20	570,0	273,0	329,0	56,9			87	87

TECHNOLOGICALS

FLATTENING TEST: GOOD
RING EXPANDING TEST: GOOD

METALLURGICAL TEST

INTERGRANULAR CORROSION: A-262 PRACT."E", ISO 3651-2: NOT OBJECTIONS

NON DESTRUCTIVE TEST

100 % EDDY CURRENT TEST AT E.426 , GOOD
STEEL GRADE CHECKING ON EACH TUBE BY SPECTROMETRY (PMI): SATISFACTORY
DIMENSIONAL CHECKING ON EACH TUBE, SATISFACTORY
VISUAL INSPECTION ON EACH TUBE, SATISFACTORY

OTHER MATERIAL SPECIFICATIONS

EN 10216-5 TC1 X5CRNI18-10 WN. 1.4301
EN 10216-5 TC1 X2CRNI18-9 WN. 1.4307

MARKS

TX2
TUBACEX 33,4 X 4,55 EN 10216-5 TC1 X5CRNI18-10 WN 1.4301 /
X2CRNI18-9 WN 1.4307 CFD - ASTM-ASME A-SA 312 TP304-304L SMLS
HEAT/..... NH ET PMI TX2
TOL. EN ISO 1127 D3/T3.

REMARKS

T.T.I GARANTIT QUE TOUS LES TUBES LIVRES SONT CONFORMES AUX SPEC.S DE L'ARTICLE 15 DE L'ARRETE MINISTERIEL DU 24 MARS 1978 MODIFIE

CUTIA CONTINERE ALL'ORIGINALI TUBACEX INOX S.R.L.

 EN-006/1998	 Gestión Ambiental 00M04192	<p>We hereby certify that the material herein described has been manufactured, sampled, tested and inspected in accordance with above standards and specifications and satisfies the order's requirements.</p> <p>This certificate is issued by a computerized system and it is valid without original signature. In case the owner of this certificate would release a copy of it he must accept its conformity to the issued, assuming the responsibility for any alteration or T.T.I.S.A. not allowed use.</p> <p>Any forgery or falsification of this certificate shall legally prosecuted.</p>	<p style="text-align: right;">T.T.I. Tubacex Tubos Inoxidables, S.A. INGENIERA DE CALIDAD</p> Jon Alkorta Zubizarreta
-------------------------	---------------------------------------	---	--



T.T.I. - Tubacex Tubos Inoxidables, S.A.

Registro Mercantil de Aleva, Tomo 587, Folio 188, Hoja VI 2886 - N.I.F. A-81140227

Printed on:
26.06.2009

INSPECTION CERTIFICATE

EN 10204 3.1

Number: 425772
Page: 2 / 2

Rev: 0

Date: 26.06.2009 26.06.2009

CUSTOMER : PO : 216-6/2/09 OUR REFERENCE: K0146
 STANDARD : ASME 2001 PART.A SEC.II A/SA312 ED.07 AD-2000 W2 2003 "EINBAUROHRE"
 ADDIT. SPECS : DOC.NO. MTS-PS-001 AND NACE MR01.75-03/ISO 15156-3
 GRADE : TP304/304L
 DIMENSIONS : 33,4 X 4,55
 MATERIAL : SEAMLESS STAINLESS STEEL TUBE
 COLD ROLLED; PICKLED-PASSIVATED;
 PLAIN ENDS SQUARE CUT;

C<=0,25%, P<=0,05%, S<=0,05%, R<800 N/MM2, E<=0,9 * R
 A% (LO=5,65VSO) MIN, 16% EN LONG. R(A 2)>=10500
 MATERIAL MANUFACTURER APPROVED WITH CERTIFICATE NR. 07/2001/MUC BY TÜV SÜDDEUTSCHLAND
 (NOTIFIED BODY 0036) TO ISSUE CERTIFICATES OF SPECIFIC PRODUCT CONTROL IN
 ACCORDANCE WITH PRESSURE EQUIPMENT DIRECTIVE 97/23/EC ANNEX 1 POINT 4.3.
 MATERIAL CHARACTERISTICS COMPLY WITH POINT 7.5 OF ANNEX I TO PED BY HAVING AN ELONGATION
 AFTER RUPTURE AT TENSILE TEST NO LESS THAN 14 % AND A BENDING RUPTURE ENERGY AT IMPACT TE
 ST NO LESS THAN 27 J AT 20°C.



We hereby certify that the material herein described has been manufactured, sampled, tested and inspected in accordance with above standards and specifications and satisfies the order's requirements.
 This certificate is issued by a computerized system and it is valid without original signature.
 In case the owner of the certificate would release a copy of it, he must stand its conformity to the issued, assuming the responsibility for any misuse or T.T.I.S.A. not allowed use.
 Any forgery or falsification of this certificate shall legally prosecuted.

T.T.I.
Tubacex Tubos Inoxidables, S.A.

INGENIERIA DE CALIDAD

[Handwritten signature]
Jon Atxaga Zubizarreta

ER-0006/1991

COM-01137

Date

2010-04-06

Riferimenti del cliente**Indirizzo del cliente**

SIG.MARINELLI
R.T.I. SPA
VIA AMBROSOLI 2/A
20090 RODANO MILLEPINI MI
Italy

Codice prodotto Cliente

FBBLR-304L-1-80S

Numero d'ordine

ORD.29527/10 29.3

Riferimenti di Sandvik**Codice prodotto Sandvik**

FBBLR-304L-1-80S

Lunghezza**Lotto****Colata**

J0701-099

Quantità consegnata

1 Pieces

Numero d'ordine del cliente

255501

Linea d'ordine del cliente

3

DDT Nr

15900



LIXUE STEEL PIPE CO.,LTD.

TINGTIAN INDUSTRIAL ZONE RUIAN CITY, ZHEJIANG, CHINA

MILL TEST CERTIFICATE IN ACC. WITH EN 10204 3.1 ISO9001:2000+PED97/23/EC+AD2000

Client		Santrade Ltd		Certificate No		091122-7	
Contract NO		GF20091106		Delivery Conditions		Solution Annealed, pickled and passivated	
Product		STAINLESS STEEL COLD FORMED BUTT WELD FITTINGS		Specification		ASTM/ASME A/SA 403-06 ANSI B16.9-07	
Item	Quantity	Size	Description	Grade	Heat No.	Heat treatment	Quenching
52	50	2"X1 1/2" SCH10S	Concentric Reducers	WP316/316L-S	B189	1052* 15 min.	RWQ
53	10	2"X1 1/2" SCH40S	Concentric Reducers	WP316/316L-S	YT082283	1052* 15 min.	RWQ
55	20	3"X2" SCH40S	Concentric Reducers	WP316/316L-S	TG090191	1052* 15 min.	RWQ
56	20	3"X2 1/2" SCH10S	Concentric Reducers	WP316/316L-S	YT080403	1052* 15 min.	RWQ
57	3	8"X5" SCH10S	Concentric Reducers	WP316/316L-S	YD08-026	1052* 15 min.	RWQ
58	50	2" SCH80S	Equal Tees	WP316/316L-S	TG080335	1052* 15 min.	RWQ
60	25	1" SCH80S	Long Radius Elbows 90°	WP304/304L-S	J0701-099	1052* 15 min.	RWQ

chemical composition (%)									
Heat No.	C	Mn	P	S	Si	Cr	Ni	Mo	Ti
B189	0.024	0.93	0.041	0.002	0.44	16.42	10.22	2.08	
YT082283	0.021	0.87	0.038	0.003	0.330	16.70	11.08	2.09	
TG090191	0.023	0.81	0.040	0.003	0.350	16.64	11.10	2.07	
YT080403	0.020	0.86	0.040	0.001	0.40	16.62	11.10	2.06	
YD08-026	0.022	0.80	0.039	0.005	0.36	16.60	10.10	2.04	
TG080335	0.020	0.81	0.039	0.001	0.380	16.74	11.08	2.07	
J0701-099	0.022	0.85	0.033	0.001	0.39	18.23	8.10		

Mechanical Properties					NACE MR0175	IC Test ASTM A262E	Impact Test	Non-destructive Test		PMI	Visual	Dimensional
Heat No.	TS(Mpa)	YS (Mpa)	EL(%)	Hardness				PT				
B189	570	250	65	HRB≤90	OK	OK	N/A	OK	OK	OK	OK	
YT082283	550	240	58	HRB≤90	OK	OK	N/A	OK	OK	OK	OK	
TG090191	565	265	58	HRB≤90	OK	OK	N/A	OK	OK	OK	OK	
YT080403	535	225	58	HRB≤90	OK	OK	N/A	OK	OK	OK	OK	
YD08-026	570	325	75	HRB≤90	OK	OK	N/A	OK	OK	OK	OK	
TG080335	565	275	64	HRB≤90	OK	OK	N/A	OK	OK	OK	OK	
J0701-099	580	275	64	HRB≤90	OK	OK	N/A	OK	OK	OK	OK	

MARKINGS: LIXUE - SPEC - SIZE - SCH - GRADE - HEAT NO

Materials have been manufactured in complete accordance with the purchase order

QUALITY ASSURANCE APPROVAL

16. Dez. 2009

Signed: [Signature]
Date: 2009.11.22

Q.A. Manager



SANDVIK TALIA S.p.A.
REVIEWED

SANTRADE LTD LUXEM

PN 24052



T.T.I. - Tubacex Tubos Inoxidables, S.A.

Registro Mercantil de Alava, Tomo 687, Folio 188, Hoja VI 2888 - N.I.F. A-41140227

Printed
19.01.

INSPECTION CERTIFICATE

EN 10204 3.1

Number: 417490
Page: 1 / 2

Rev: 6

Date: 19.12.2008

19.12.2008

CUSTOMER : PO : C02647 OUR REFERENCE: J9378
 STANDARD : DIN 17450 PK1/EN 10216-5 TC1 AD-2000 W2/W10/TRD100
 ADDIT. SPECS : NACE MR01.75-03 / ISO 15156
 GRADE : 1.4301/1.4306
 DIMENSIONS : 21,34 X 3,73
 MATERIAL : SEAMLESS STAINLESS STEEL TUBE
 COLD ROLLED; PASSIVATED;
 FLAIN ENDS SQUARE CUT;

---ITEM---	---HEAT---	NO. OF	---WEIGHT---	---TOTAL LENGTH---	---UNIT LENGTH---
YOUR	TTI.	PIECES	KG		
	3 40405	113	1152	686,90	5,5 - 6,5 MT

RAW MATERIAL

MELTING PROCESS: ELECTRIC FURNACE + A.O.D FROM: ACERALAVA
 PEELED BARS; MACROETCH TESTING: GOOD;

CHEMICAL COMPOSITION (*1 L: LADLE; C: PRODUCT)

*1 HEAT	C	Mn	Si	P	S	Ni	Cr	Cu	B	N
L 40405	0,012	1,49	0,290	0,032	0,0010	10,15	18,25	0,34	0,0009	0,0720



HEAT TREATMENT

SOLUTION ANNEALED 1100 °C HOLDING TIME >=1.5 MIN/MM WATER QUENCHED

= TESTS =		-----TENSION-----				--IMPACT TESTS--		HARDNESS			
NR.	TEST	T(°C)	MPA	R _m	R _p 0,2	R _p 1,0	A	Z	T(°C) MINIMUM	AVERAGE	HRB
40405	813809	20	603,0	303,0	345,0	58,8					85 86

TECHNOLOGICALS

FLATTENING TEST: GOOD
 FLARING TEST: GOOD
 RING EXPANDING TEST: GOOD

METALLURGICAL TEST

INTERGRANULAR CORROSION: A.262 PRACT. "E" / ISO 3651-2 : NOT OBJECTIONS

NON DESTRUCTIVE TEST

100 % HYDROSTATIC PRESSURE TESTED AT 80 BAR , DURING 6 SEC, GOOD
 STEEL GRADE CHECKING ON EACH TUBE BY SPECTROMETRY (PMI): SATISFACTORY
 DIMENSIONAL CHECKING ON EACH TUBE, SATISFACTORY
 VISUAL INSPECTION ON EACH TUBE, SATISFACTORY

OTHER MATERIAL SPECIFICATIONS

A-SA312M-06 ED.07/NF A49117-85 TP304-304L/Z2-Z6 CN 18.10-09

MARKS

TX2
 TUBACEX 21,34 X 3,73 1.4301-1.4306 H S 1 - EN 10216-5 TC1 1.4301-
 1.4306 CFD - NF A49-117 Z2-Z6 CN 18.10-09 - A-SA 312 TP304-304L SMUS
 HEAT/..... PMI TX2 SPAIN

REMARKS

TOL ISO T32 D3/T3
 MATERIAL MANUFACTURER APPROVED WITH CERTIFICATE NR. 07/2001/MUC BY TÜV SÜDDEUTSCHLAND
 (NOTIFIED BODY 0036) TO ISSUE CERTIFICATES OF SPECIFIC PRODUCT CONTROL IN
 ACCORDANCE WITH PRESSURE EQUIPMENT DIRECTIVE 97/23/EC ANNEX 1 POINT 4.3.
 AS PER LETTER DATED 21.08.92 TÜV SÜDWEST DECLINES COUNTERSIGNING
 MATERIAL CHARACTERISTICS COMPLY WITH POINT 7.5 OF ANNEX I TO PED BY HAVING AN ELONGATION
 AFTER RUPTURE AT TENSILE TEST NO LESS THAN 14 % AND A BENDING RUPTURE ENERGY AT IMPACT TE



We hereby certify that the material herein described has been manufactured, sampled, tested and inspected in accordance with above standards and specifications and satisfies the order's requirements.
 This certificate is issued by a computerized system and it is valid without original signature.
 In case the owner of the certificate would release a copy of it, he must accept its conformity to the issued, assuming the responsibility for any misuse of T.T.I., S.A. not allowed use.
 Any forgery or falsification of this certificate shall legally prosecuted.

T.T.I.
 Tubacex Tubos Inoxidables, S.A.

INGENIERIA DE CALIDAD



Juan Alana Zubizarain



TUBACEX

T.T.I. - Tubacex Tubos Inoxidables, S.A.

Registro Mercantil de Aleva, Tomo 587, Folio 189, Hoja VI 2005 - N.I.F. A-01148227

Printed on:
19.01.2009

INSPECTION CERTIFICATE

EN 10204 3.1

Number: 417490
Page: 2 / 2

Rev: 0

Date: 19.12.2008

19.12.2008

CUSTOMER : PO : **C02647** OUR REFERENCE: **J9378**
 STANDARD : **DIN 17458 PK1/EN 10216-5 TC1 AD-2000 W2/W10/TRD100**
 ADDIT. SPECS : **NACE MR01.75-03 / ISO 15156**
 GRADE : **1.4301/1.4306**
 DIMENSIONS : **21,34 X 3,73**
 MATERIAL : **SEAMLESS STAINLESS STEEL TUBE**
COLD ROLLED; PASSIVATED;
PLAIN ENDS SQUARE CUT;

ST NO LESS THAN 27 J AT 20°C.

CONFORME ALL'ORIGINALE
RUBIVAL INOX S.R.L.



We hereby certify that the material herein described has been manufactured, sampled, tested and inspected in accordance with above standards and specifications and satisfies the order's requirements.
The certificate is issued by a computerized system and it is valid without original signature.
In case the owner of the certificate would release a copy of it, he must attend its conformity to the issued, assuming the responsibility for any error or T.T.I. S.A. not identical use.
Any forgery or falsification of this certificate shall legally prosecuted.

T.T.I.
Tubacex Tubos Inoxidables, S.A.

INGENIERIA DE CALIDAD

[Signature]
Joni Alzola Zubizarreta

Allegato 5:

Lista materiali certificati: Disegno 074-00-01rev3 tav. 5, esterno scambiatore

Assieme

IMPIANTO PROVA BARRE

N°Riferimento Disegno 074.00.01 Rev.: 3 Tav. 5 rev .3 Data: 25/06/2010

Part. N°	Descrizione	Quantità	Lunghezza (mm)	Materiale	N°Certificato	Data Certificato	Fabbricante	N°di colata	Note
4	Flangia WN 2" ansi 2500 LF	1	-	ASTM A182 F304	53/10-1	29/04/'10	Steeltrade	379250	
25	Flangia WN 2" ansi 2500 LM	1	-	ASTM A182 F304	53/10-1	29/04/'10	Steeltrade	379250	
52/1	Tube 2" sch.160	1	4667	ASTM AISI 304	428723	06/10/'09	T.T.I. Tubacex	41544	

Compilato da: 

Data: 25/06/2010

CERTIFICATE OF CHEMICAL ANALYSIS AND MECHANICAL TEST.



STEELTRADE s.r.l.
 Loc. CATTAGNINA
 29010 ROTTOFRENO (PC) - ITALY
 TEL. +39 0523 780121
 FAX +39 0523 780123
 E-mail: inspection@steeltrade.it
 WEB: http://www.steeltrade.it

CERTIFICATE N. :53/10-1
 DATED :29/04/10

PURCHASER : SIET

YOUR ORDER : 74-10

JOB N. : ST 53/10

ITEM	Q.TY N°	DESCRIPTION	MATERIAL	HEAT CODE	HEAT
ITEM 01	4	WN FLANGE 1" LARGE MALE SCH.80 ANSI 2500	ASTM A182 F304	0B3	374150
ITEM 02	6	WN FLANGE 1" LARGE FEMALE SCH.80 ANSI 2500	ASTM A182 F304	B540	508471
ITEM 03	1	SLIP ON FLANGE 3" RF CL150	ASTM A182 F304	B248	259170
ITEM 04	1	SLIP ON FLANGE 2" RF CL150	ASTM A182 F304	B140	21728
ITEM 05	1	BLIND FLANGE 3" RF CL600 FORATA DIAM. 61 mm	ASTM A182 F304	B254	444625
ITEM 06	1	BLIND FLANGE 2" RF CL150 FORATA DIAM. 34 mm	ASTM A182 F304	B266	D82126A
ITEM 07	8	WN FLANGE 2" LARGE MALE SCH.160 ANSI 2500	ASTM A182 F304	B500	379250
ITEM 08	9	WN FLANGE 2" LARGE FEMALE SCH.160 ANSI 2500	ASTM A182 F304	B500	379250
ITEM 09	1	WN FLANGE 3/4" LARGE MALE SCH.160 ANSI 2500	ASTM A182 F304	B273	291450
ITEM 10	1	WN FLANGE 3/4" LARGE FEMALE SCH.160 ANSI 2500	ASTM A182 F304	B273	291450

Chemical Analysis

HEAT	C%	Mn%	Si%	P%	S%	Mo%	Cr%	Ni%	V%	Cu%	Ti%	Nb%	C.eq% *
374150	0.023	1.78	0.35	0.0028	0.0021		18.43	8.91					
508471	0.009	1.12	0.40	0.028	0.0026		18.14	9.12					
259170	0.014	1.75	0.31	0.026	0.024		18.33	8.14					
21728	0.017	0.77	0.32	0.028	0.002		18.25	9.20					
444625	0.013	1.10	0.41	0.026	0.026		18.20	9.22					
D82126A	0.019	1.61	0.42	0.025	0.025		18.26	10.17					
379250	0.022	1.71	0.24	0.03	0.021		18.22	8.93					
291450	0.022	1.76	0.31	0.029	0.026		18.32	8.20					

Mechanical Properties

HEAT	TENSILE TEST					IMPACT TEST					
	Tensile strength N/mm2	Yield point N/mm2	Elongation 2" %	Red. of Area %	Hardness HB	Type	Section	Temp.	Values J	Values J	Values J
374150	606	341	47.2	60.3							
508471	549	348	52.6	74.8							
259170	582	241	61.0	70.4							
21728	525	375	49.0	73.0							
444625	577	278	57.0	69.0							
D82126A	576	242	53.0	71.0							
379250	576	281	57.0	72.6							
291450	580	274	59.7	75.0							

NOTE:

- CERTIFICATE CONFORM TO : EN 10204.3.1
- STEEL MADE BY ELECTRIC FURNACE
- HEAT TREATMENT : SOLUTION ANNEALED
- ACCORDING TO PED 97/23/EC ANNEX 1 PAR.4.3
- PMI : NO OBJECTION (100% TESTED WITH NITON ANALYZER)
- DIMENSIONS : ASME B16.5
- VISUAL AND DIMENSIONAL TEST : SATISFACTORY

Quality Control
STEELTRADE



*C. eq. by long formula

The present certificate is in fully accordance with UNI CEI EN 45014-90



T.T.I. - Tubacex Tubos Inoxidables, S.A.

Registro Mercantil de Alava, Tomo 587, Folio 198, Hoja VI 2886 - N.I.F. A-01140227

Printed on:
21.10.2009

INSPECTION CERTIFICATE

EN 10204 3.1

Number: 428723

Page: 1 / 2

Rev: 0

Date: 06.10.2009

06.10.2009

CUSTOMER : PO : **C02989*** OUR REFERENCE: **K0002**
 STANDARD : **EN 10216-5 TC2**
 ADDIT. SPECS : **NACE MR01.75-03 / NACE MR03-03 / ISO 15156-3**
 GRADE : **1.4301/1.4306**
 DIMENSIONS : **60,32 X 8,74**
 MATERIAL : **SEAMLESS STAINLESS STEEL TUBE**
COLD ROLLED; PICKLED-PASSIVATED;
PLAIN BEVELLED ENDS;

ITEM	HEAT	NO. OF	WEIGHT	TOTAL LENGTH	UNIT LENGTH	
YOUR	TTI.	PIECES	KG			
	66	41544	28	1933	172,52	5,5 - 6,5 MT

RAW MATERIAL

MELTING PROCESS: ELECTRIC FURNACE + A.O.D FROM: ACERALAVA
 PEELED BARS; MACROETCH TESTING: GOOD;

CHEMICAL COMPOSITION (*1 L: LADLE; C: PRODUCT)

*1 HEAT	C	Mn	Si	P	S	Ni	Cr	N
L 41544	0,017	1,50	0,300	0,027	0,0010	10,15	18,30	0,0720

HEAT TREATMENT

SOLUTION ANNEALED 1100 °C HOLDING TIME >=1.5 MIN/MM WATER QUENCHED

TESTS		TENSION				IMPACT TESTS		HARDNESS	
NR.	NR.	T(°C)	MPA	RP 0,2	RP 1,0	A	Z	T(°C) MINIMUM AVERAGE	HRB
HEAT	TEST								
41544	908135	20	550,0	321,0	369,0	46,7			81 82
41544	908135A	20	550,0	322,0	369,0	45,3			81 82

TECHNOLOGICALS

FLATTENING TEST: GOOD
 RING EXPANDING TEST: GOOD

METALLURGICAL TEST

INTERGRANULAR CORROSION: A262 "E"/ISO 3651-2/ 5 TEST ACC.MIL-P-1144D+24691/3: GOOD

NON DESTRUCTIVE TEST

100 % U.T TO EN10246-7 (ENT.5%, MIN.0,3MM) , GOOD
 100 % EDDY CURRENT TEST AT E-426 , GOOD
 100 % HYDROSTATIC PRESSURE TESTED AT 80 BAR , DURING 5 SEC, GOOD
 STEEL GRADE CHECKING ON EACH TUBE BY SPECTROMETRY (PMI): SATISFACTORY
 DIMENSIONAL CHECKING ON EACH TUBE, SATISFACTORY
 VISUAL INSPECTION ON EACH TUBE, SATISFACTORY



OTHER MATERIAL SPECIFICATIONS

A/SA312M-08A ED.07 + 08 ADD TP304-304L
 A/SA376M-06 ED.07 + 08 ADD TP304

MARKS

TX2
 TUBACEX 60,32 X 8,74 EN 10216-5 TC2 1.4301-1.4306 CFD ASTM-ASME
 A-SA 312 TP304-304L A-SA 376 TP304 SMLS HEAT/..... PMI TX2
 SPAIN

REMARKS

TOL. ISO 1127 D3-T3 / ASTM A999
 NO WELD REPAIR WAS PERFORMED

COPIA CONFORME ALL'ORIGINALE



We hereby certify that the material herein described has been manufactured, sampled, tested and inspected in accordance with above standards and specifications and satisfies the order's requirements.
 This certificate is issued by a computerized system and it is valid without original signature. In case the owner of this certificate would request a copy of it, he must advise its conformity to the issuer, assuming the responsibility for any unlawful or T.T.I.,S.A. not allowed use.
 Any forgery or falsification of this certificate shall legally prosecuted.

T.T.I.
 Tubacex Tubos Inoxidables, S.A.

INGENIERIA DE CALIDAD

[Signature]
 JON ARBIDE ZUBEROA



T.T.I. - Tubacex Tubos Inoxidables, S.A.

Registro Mercantil de Álava, Tomo 587, Folio 188, Hoja VI 2886 - N.I.F. A-61140227

Printed on:
21.10.2009

INSPECTION CERTIFICATE

EN 10204 3.1

Number: 428723
Page: 2 / 2

Rev: 0

Date: 06.10.2009 06.10.2009

CUSTOMER : PO : **C02989*** OUR REFERENCE: **K0002**

STANDARD : **EN 10216-5 TC2**

ADDIT. SPECS : **NACE MR01.75-03 / NACE MR03-03 / ISO 15156-3**

GRADE : **1.4301/1.4306**

DIMENSIONS : **60,32 X 8,74**

MATERIAL : **SEAMLESS STAINLESS STEEL TUBE**
COLD ROLLED; PICKLED-PASSIVATED;
PLAIN BEVELLED ENDS;

MATERIAL MANUFACTURER APPROVED WITH CERTIFICATE NR. 07/2001/MUC BY TÜV SÜDDEUTSCHLAND (NOTIFIED BODY 0036) TO ISSUE CERTIFICATES OF SPECIFIC PRODUCT CONTROL IN ACCORDANCE WITH PRESSURE EQUIPMENT DIRECTIVE 97/23/EC ANNEX 1 POINT 4.3. MATERIAL CHARACTERISTICS COMPLY WITH POINT 7.5 OF ANNEX I TO PED BY HAVING AN ELONGATION AFTER RUPTURE AT TENSILE TEST NO LESS THAN 14 % AND A BENDING RUPTURE ENERGY AT IMPACT TEST NO LESS THAN 27 J AT 20°C.



We hereby certify that the material herein described has been manufactured, sampled, tested and inspected in accordance with above standards and specifications and satisfies the order's requirements.

This certificate is issued by a computerized system and it is valid without original signature. In case the owner of the certificate would release a copy of it, he must state its conformity to the issued, assuming the responsibility for any unlawful or T.T.I., S.A. not allowed use.

Any forgery or falsification of this certificate shall legally prosecuted.

T.T.I. Tubacex Tubos Inoxidables, S.A.

INGENIERIA DE CALIDAD

[Signature]
Jon Albano Zubizarreta

Allegato 6:

Lista materiali certificati: Disegno 074-00-01rev3 tav. 6, venturimetro



LISTA MATERIALI CERTIFICATI

DATA 17/06/10

PAGINA 1 di 1

Assieme

IMPIANTO PROVA BARRE

N°Riferimento Disegno

074.00.01

Rev.:

3

Tav. 6 rev .2

Data:

25/05/2010

Part. N°	Descrizione	Quantità	Lunghezza (mm)	Materiale	N°Certificato	Data Certificato	Fabbricante	N°di colata	Note
4	Flangia WN 2" ansi 2500 LF	1	-	ASTM A182 F304	851711/2010	23/03/'10	Acc. Valbruna	247813	Custom
25	Flangia WN 2" ansi 2500 LM	1	-	ASTM A182 F304	"	"	"	247813	Custom
61/1	Tubo 2" sch.160 (ventur. incl.)	1	1069	ASTM AISI 304	1323295	25/02/'08	Sidenor	41953	Custom
61/2	Corpo venturimetro	1	-	ASTM AISI 304	1317772	2012/'07	"	98886	Custom

Compilato da:

Data:

17/06/10

TEST CERTIFICATE VISUAL E DIMENSIONAL (CERTIFICATO DI CONTROLLO VISIVO E DIMENSIONALE) I/064-R10 Page 1 of 1

Customer (Cliente)	P.O. (Ordine)	Q.C.P. - I.Y.P.	Tecnomatic Procedure	Plant (Impianto)	TM Job (Commessa N.)
S.I.E.T.	43-10				064-R10

RESULT (RISULTATI)

Quantity Pezzi	P.O. Item Ordine	Product (Prodotto)	Model/Tag (Modello/Signa)	Material (Materiale)	Test Pressure (Pressione di Prova)		
					Shell Test (Tenuta Corpo)	Seal Test (Tenuta Sede)	Outside (Esterna)
1	01	TUBO VENTURI DN 2" ANSI 2500 WN-LM /LF		AISI 304	260 BAR	/	/

TEST RESULT (ESITO DEL COLLAUDO)

Conforming (Conforme)		Purchaser's Inspector (Ispettore Cliente) Date (Data)	TM Inspector (Ispettore TM) Date (Data)
Not Conforming (Non Conforme)		Date (Data)	Date (Data)



MATERIAL DETAIL (RIEPILOGO MATERIALI)

N. 2/064-R10 Page 1 of 1

Customer (Cliente) S.I.E.T.		Order (Ordine) N. 43-10	TM Job (Commessa N.) 064-R10
Quality Plan No. (PFC N.)	Step (Fase)	Plant (Impianto)	

DESCRIPTION (DESCRIZIONE)

Drawing No. (Disegno N.)	Item (Pos)	Product (Prodotto)	Material (Materiale)	Heat No. (Colata N.)	Supplier (Fornitore)	Certificate Certificato
064-R10.D01	1	VENTURI BODY	AISI 304	98886	SIDENOR	1317772
"	2	FLANGE 2" ANSI 2500 WN-LF	AISI 304	247813	ACCIAIERIE VALBRUNA	851711/2010
"	3	FLANGE 2" ANSI 2500 WN-LM	AISI 304	247813	ACCIAIERIE VALBRUNA	851711/2010
"	4	PIPE 2" SCH. 160	AISI 304	41953	SIDENOR	1323295
"	5	PRESSURE TAPS 1/4"NPT-F	AISI 304	9RN6	ACCIAIERIE VALBRUNA	775434/2009

Tecnomatic Inspector (Ispettore TM)	Purchaser's Inspector (Ispettore Cliente)	Authorized Inspector (Ispettore Ente Autorizzato)
Date (Data) 27/04/2010	Date (Data)	Date (Data)



COMM. 11-R08



SIDENOR

MILL TEST CERTIFICATE



Basauri Plant

ISO 9001 - ISO/TS 16949

CUSTOMER:TERNINOX, SPA	WORKS REFERENCE:1317772
REFERENCE:113934	SALES ORDER:188229-10
PRODUCT NR:	HEAT NUMBER:98886
	VERSION:96659
	ROLLED:05.12.2007

REQUIRED PRODUCT			
AISI304/304L(1.4301/1.4307) IM ROUND BARS TURNED SOLUTION ANNEALING 75 +0/+0,46 mm			
ISO X13 4.500/6.000 mm RANDOM			
EXPEDITION	DELIVERY:80206362	WEIGHT (KG):2.880	BUNDLES:2
			UNITS:14

MADE ACCORDING TO	
ASTM A276 - 2002 ; AD-W2 - 01.09.1998 ; AD-W10 - 01.11.1987 ; DIN 17440 - .09.1996	
ASTM A479-A479M - 2003 ; ASTM A182-A182M - 2007 ; EN 10088-3 - 01.04.1995	
ASME SA479-SA479M - 2004 ; ASME SA182-SA182M - 2001 ; NACE MR0175 2002 01.01.2002	
AISI STAINLESS STEELS - 01.03.1999 ; EN DIRECTIVA 97/23/CE:97 - 29.05.1997	
TERNINOX FICHA TECNICA ED1 1 29.10.2004 ; EN 10204 :2004 OCT. 2004 3.1	

CHEMICAL ANALYSIS OF HEAT									U: % HEAT NUMBER:98886
	C	Mn	Si	P	S	Cr	Ni	N	
Min.					0,015	18,000	8,000		
Max.	0,030	2,000	0,750	0,045	0,030	19,500	10,000	0,1000	
cer.	0,020	1,840	0,346	0,020	0,024	18,200	8,070	0,0850	

MECHANICAL PROPERTIES AS SUPPLIED (CONDITIONS)	
Specimen Test location:At 12,5 mm from the surface ; Temperature of: (1):Solution annealing 1.040 °C	
Cooling: (1):Air	

MECHANICAL PROPERTIES AS SUPPLIED (TEST)	
Tensile test specimen direction (Longitudinal):Longitudinal	
Tensile Strength (517/600 N/mm2):614 N/mm2	
Yield Strength(1) (Rp(0.2%)) => 207 N/mm2;Rp(0.2%) 272 N/mm2	
Yield Strength(2) (1%) => 230 N/mm2;(1%) 318 N/mm2 ; Elongation ((5d)) => 45 %;(5d) 56,2 %	
Reduction of Area (>= 50 %):72,9 % ; Notch impact sample direction (Longitudinal):Longitudinal	
Notch Impact sample type (ISO V):ISO V ; Notch Impact test Temperature (20 °C):20 °C	
K(1) (>= 100 J):281 J ; K(2):277 J ; K(3):280 J ; Hardness (<= 215 HB):153 HB	

ADDITIONAL TESTS	
Standard (ASTM E112-96- . .1996) ; Grain size:Austenitic 6 ; Standard (ASTM A262-01-2001)	
Type / Method (Practice E) ; Interglystalline Corrosion:O.K.	

TECNOMATIC S.p.A Quality Control	
WITNESSED <input type="checkbox"/>	REVIEWED <input checked="" type="checkbox"/>
Date	22/02/10
Signature	

CORPO VENTURI

TECHNOLOGY & QUALITY CERTIFIES THAT THE PRODUCT FULL FILLS THE ORDER'S SPECIFICATION		
APPROVED BY:MARCELINO GARCIA ZAVAS	Page 1 of 1	SIGN:
DATE:20.12.2007		SIDENOR BAS AURIE
REF.:1981047700090		Metallurgical Technical Approval Level II



04-R10

36100 VICENZA (Italia) - Viale della scienza, 25 z.l.
 Stab.: 39100 BOLZANO (Italia) - Via A. Volta, 4

Cliente / Besteller/Purchaser/Client
 TM TECNOMATIC SPA
 VIA DELLE INDUSTRIE, 36
 26100-CREMONA-CR

Produttore: ACCIAIERIE VALBRUNA S.P.A.
 Hersteller/Fabrikant/Usine producer

Oggetto Prove: - Solubilizzato Pelato
 Prüfgegenstand/Item Inspected/Prüfung

Avviso di Spedizione: A-
 Lieferungsgepäckung Art.B.L.

Ordine nr: VS ORDINE 216
 Bestell/Nr order/Commande

Tipo di Elaborazione: E+AOD
 Bearbeitungsart/Welding process/Mode d'elaboration

Certificato nr: MEST851711/2010/
 Prüfung/Test/Essai

Conferma ordine nr: BS10000874
 Bestell/Nr Order/Ref nr.

Marchio di Fabbrica:
 Zeichen des Lieferanten
 Trade mark
 Signe de l'usine productrice

Funzione del Collaudatore:
 Stempel des Werkssachverständigen
 Inspector's stamp/Prüfer de l'essayeur



Specifiche:

Anforderungen / Requirements / Exigences

VAL STOCK 2005 1.4307/304L A
 AMS 5639 H S30400 A
 AMS-QQ-S-763 B 304L A
 ASME SA193 2007 B8 CLASS1 a
 ASME SA320 2007 B8 CLASS1 s
 ASTM A182 2008A S30400 A a
 ASTM A262 2002A PRACTICE E
 ASTM A320 2008 B8 CLASS1
 DIN 17440 96 1.4301 A
 EN 10222-5 99 1.4301 A
 NACE MR0175* 2003 S30403 A b

(0) SEC.II PT.A 2007 EDITION
 (1) SEC.II PT.A 2007 EDITION
 (2) SEC.II PT.A 2007 EDITION
 (4) SEC.II PT.A 2007 EDITION
 (6) SEC.II PT.A 2007 EDITION
 (8) Chemical analysis only and mechanical properties.
 (A) * ISO 15156-3

AISI 304
 AMS 5647 H S30403 A
 ASME SA182 2007 S30400 A a
 ASME SA276 2007 S30400 A a
 ASME SA479 2007 S30400 A a
 ASTM A182 2008A S30403 A a
 ASTM A276 2008 S30400 A
 ASTM A479 2006A S30400 A
 EN 10088-3 2005 1.4301 A
 EN 10222-5 99 1.4307 A
 QQ-S-763 F 304 A

AISI 304L
 AMS-QQ-S-763 B 304 A
 ASME SA182 2007 S30403 A (1)
 ASME SA276 2007 S30403 A (4)
 ASME SA479 2007 S30403 A (7)
 ASTM A193 2008B B8 CLASS1
 ASTM A276 2008 S30403 A
 ASTM A479 2006A S30403
 EN 10088-3 2005 1.4307 A
 NACE MR0175* 2003 S30400 A (A)
 QQ-S-763 F 304L A

0Chemical analysis only and mechanical properties.
 1Chemical analysis only and mechanical properties.
 3SEC.II PT.A 2007 EDITION
 5SEC.II PT.A 2007 EDITION
 7SEC.II PT.A 2007 EDITION
 9Chemical analysis only and mechanical properties.
 B* ISO 15156-3

Qualità: 1.4307/304/304L
 Werkstoff/Grade/Qualité

Marca: MVAISL MAXIVAL
 Markenbezeichnung/Brand/Marque

Punzonatura: 1.4307/304/304L
 Kennzeichnung/Marking/Étiquette

TECNOMATIC S.p.A.
Quality Control
 WITNESSED REVIEWED
 Date: 23/04/10
 Signature: _____

Pos. nr. Pos. nr. Item nr. Nr. de poste	Oggetto Gegenstand Product description Description du produit	Dimensioni - mm Abmessungen Dimension Dimension	Tolleranza Toleranz Allowance Tolérance	Lunghezza - mm Länge Length Longueur	Colata Schmelze Heat Coulée	Pezzi Stückzahl Pieces Pièces	Peso - KG Gewicht Weight Poids	Lotto nr. Losn. Lot nr. Lot nr.
0010	Tondo	240,000	k12	4010 / 4010	247813		100,0	829602570

Sono state soddisfatte tutte le condizioni richieste
 Die gestellten Anforderungen sind b. Anlage erfüllt
 The material has been furnished in accordance with the requirements
 Le matériel a été livré conforme aux exigences

Controllo antimescolanza: OK
 Verwechslungsprüfung: spezialspezifisch durchgeführt
 Antimixing testing performed: OK
 Contrôle antimélange fait: r.a.s.

Controllo visivo e dimensionale: soddisfatti le esigenze:
 Beschäftigung und Ausmessung: ohne Beanstandung
 Visual inspection and dimensional check/satisfactory
 Contrôle visuel et dimension: satisfaisant

TEST ALLO STATO DI FORNITURA
 Test on delivery condition Prüfung auf lieferbaren Produkt test a l'état de livraison Prueba sobre el material así como entregado

TEST	Provetta/Probes Spezimen/Éprouvette Lap. diam. Ømm. Bohle-Diam. mm. Wich. Diam. Thickness Lap. diam. inch. mm	°C	Snervamento Dehnung Yield Stress Limite élastique Rp 0,2% N/mm2	Snervamento Dehnung Yield Stress Limite élastique	Resistenza Zugfestigkeit Tensile strength Résistance à la traction Rm N/mm2	Allungamento Bruchdehnung Elongation Allongement E 4d %	Strizione Bruchdehnung Reduction of area Strain RA %	Resilienza Kerbschlagenergie Impact Value Resilience	Durezza Härte Rockwell Dureté HB
Valori richiesti 1 Anforderungen/Required values Valeurs dimensionées		min max	207	-	517 793	- 40	- 50	-	140 223
A	10	20 L	253		558	64	75		174

TEST	min	max
Dimensioni grano x ASTM E112		4

FRANGIE 2° W.N.L.F.
 AISI 2500 UN.L.M.

TEST	Provetta/Probes Spezimen/Éprouvette Lap. diam. Ømm. Bohle-Diam. mm. Wich. Diam. Thickness Lap. diam. inch. mm	°C	Snervamento Dehnung Yield Stress Limite élastique Rp 0,2% N/mm2	Snervamento Dehnung Yield Stress Limite élastique Rp 1% N/mm2	Resistenza Zugfestigkeit Tensile strength Résistance à la traction Rm N/mm2	Allungamento Bruchdehnung Elongation Allongement A5 %	Strizione Bruchdehnung Reduction of area Strain Z %	Resilienza Kerbschlagenergie Impact Value Resilience KV J	Durezza Härte Rockwell Dureté HB
Valori richiesti 1 Anforderungen/Required values Valeurs dimensionées		min max	200	230	500 700	35 -	- -	60	- 215
B	10	20 T	231	265	546	59	65	109 104 102 174	



36100 VICENZA (Italia) - Viale della scienza, 25 z.l.
Stab.: 39100 BOLZANO (Italia) - Via A. Volta, 4

Cliente / Besteller/Purchaser/Client
TM TECNOMATIC SPA
VIA DELLE INDUSTRIE, 36
26100-CREMONA-CR

Produttore: **ACCIAIERIE VALBRUNA S.P.A.**
Hersteller/Usine producer

Oggetto Prove: - Solubilizzato Pelato
Prüfgegenstand/Item inspected/Prüfung

Avviso di Spedizione: A-
Lieferungs/Packing list/W.L.

Ordine nr: VS ORDINE 216
Bestel/Your order/Commande

Tipo di Elaborazione: E+AOD
Erweiterung/Welding process/Mode of elaboration

Certificato nr: MEST851711/2010/
Prüfung/Teil/East

Conferma ordine nr: BS10000874
Werkz/Our Order/Nr.

Marchio di Fabbrica:
Zeichen des Lieferwerkes
Trade mark
Siglo de l' usine producer



Punzone del Collaudatore:
Stempel des Werkssachverständigen
Inspector's stamp/Prüfer von d. Inspektor



TE=longitudinale/längs, T=transversale/quer, O=Oberseite/oberseitig

Analisi chimica

Chemische Zusammensetzung/Chemical Analysis/Analyse chimique

Colata / Heat Schmelze/Coulée	min - max 0,030	- 1,00	- 2,00	18,00 19,50	- 1,00	- 1,00	8,00 10,00	- -	0,040	- 0,030	0,100	- -	- -	- -	- -
	C %	Si %	Mn %	Cr %	Mo %	Cu %	Ni %	Co %	P %	S %	N %				
247813	0,016	0,65	1,91	18,30	0,56	0,44	8,35	0,100	0,028	0,030	0,089				

Intergranular corrosion test per ASTM A262 pract. E: ok.

I.Korrosion nach EN ISO 3651-2A Sensibilisierung : T1 : OK

Corrosion test per EN ISO 3651-2A sensitized T1 : OK

Melted and manufactured in Italy No welding or weld repair Material free from Mercury contamination

We declare that the finished product is checked for radioactive contamination through Portal System when it leaves the production plant.

The Quality Management System is Certified acc. Pressure Equipment Directive (97/23/EC) Annex 1, 4.3 by TÜEV and LLOYD' S

TECNOMATIC S.p.A Quality Control	
WITNESSED <input type="checkbox"/>	REVIEWED <input checked="" type="checkbox"/>
Date	27/04/10
Signature	<i>[Signature]</i>

Vicenza, 23/03/10

V00012
IMD, MCEP

il collaudatore di stabilimento / der Werkssachverständigen / Works inspector / L' agent d' usine

M. Rizzotto *[Signature]*

Pagina - 2 di 2

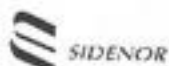

MILL TEST CERTIFICATE



Basauri Plant

ISO 9001 - ISO/TS 16949

CUSTOMER: TERNINOX, SPA	WORKS REFERENCE: 1323295
REFERENCE: 114140	SALES ORDER: 189771-5
PRODUCT NR:	HEAT NUMBER: 41953
VERSION: 96655	ROLLED: 08.02.2008

REQUIRED PRODUCT			
AISI304/304L(1.4301/1.4307) IM ROUND BARS TURNED SOLUTION ANNEALING 50 +0/+0.45 mm			
ISO k13 4.500/6.000 mm RANDOM			
EXPEDITION	DELIVERY: 80215102	WEIGHT (KG): 2.919	BUNDLES: 2
			UNITS: 32

MADE ACCORDING TO			
ASTM A276 - 2002 ; AD-M2 - 01.09.1998 ; AD-W10 - 01.11.1987 ; DIN 17440 - .09.1996			
ASTM A479-A479M - 2003 ; ASTM A182-A182M - 2007 ; EN 10088-3 - 01.04.1995			
ASME SA479-SA479M - 2004 ; ASME SA182-SA182M - 2001 ; NACE MR0175 2002 01.01.2002			
AISI STAINLESS STEELS - 01.03.1993 ; EN DIRECTIVA 97/23/CE:97 - 29.09.1997			
TERNINOX FICHA TECNICA ED1 1 29.10.2004 ; EN 10204 :2004 OCT. 2004 3.1			

CHEMICAL ANALYSIS OF HEAT									U: % HEAT NUMBER: 41953	
	C	Mn	Si	P	S	Cr	Ni	N		
Min.						0,015	18,000	8,000		
Max.	0,030	2,000	0,750	0,045	0,030	19,500	10,000	0,1000		
Car.	0,024	1,690	0,350	0,033	0,027	18,350	8,130	0,0745		

MECHANICAL PROPERTIES AS SUPPLIED (CONDITIONS)	
Specimen Test location: At 12,5 mm from the surface ; Temperature of: (1): Solution annealing 1.040 °C	
Cooling: (1): Air	

MECHANICAL PROPERTIES AS SUPPLIED (TEST)	
Tensile test specimen direction (Longitudinal): Longitudinal	
Tensile Strength (517/680 N/mm ²): 613 N/mm ²	
Yield Strength(1) (Rp(0,2%)) >= 207 N/mm ² ; Rp(0,2%): 278 N/mm ²	
Yield Strength(2) ((1%)) >= 230 N/mm ² ; ((1%)) 321 N/mm ² ; Elongation ((5d)) >= 45 %; ((5d)) 54,3 %	
Reduction of Area (>= 50 %): 75,4 % ; Notch impact sample direction (Longitudinal): Longitudinal	
Notch Impact sample type (ISO V): ISO V ; Notch Impact test Temperature (20 °C): 20 °C	
K(1) (>= 100 J): 294 J ; K(2): 292 J ; K(3): 293 J ; Hardness (<= 215 HB): 194 HB	

ADDITIONAL TESTS	
Standard (ASTM E112-96- . . .1996) ; Grain size: Austenitic γ ; Standard (ASTM A262-01-2001)	
Type / Method (Practice E) ; Intercrystalline Corrosion: OK.	

NON DESTRUCTIVE TESTS	
ULTRASONIC INSPECTION 100% ; O.K.	

TUBO 2" SCH 160

TECHOMATIO S.p.A.
Quality Control
WITNESSED REVIEWED
Date: 27/06/10
Signature:

TECHNOLOGY & QUALITY CERTIFIES THAT THE PRODUCT FULL FILLS THE ORDER'S SPECIFICATIONS

APPROVED BY: MARCELINO GARCIA ZAYAS
DATE: 25.02.2008
REF.: 1001101320004

Page 1 of 1

Metallurgical Technical Analyst Level II

SIGN:

Acciaierie Valbruna S.p.A.



38100 VICENZA (Italia) - Viale della scienza, 25 z.l.
Stab.: 38100 BOLZANO (Italia) - Via A. Volta, 4

Cliente / Abnehmer/Kunde
TM TECNMATIC SPA
VIA DELLE INDUSTRIE, 36
28100-CREMONA-CR

Produttore: **STABILIMENTO DI BOLZANO**
Hersteller/Werk/Produkt

Oggetto Prova: **Solubilizzato Pelato**
Prüfungsauftrag/Prüfungsauftrag

Avviso di Spedizione: A-
Lieferungsverhalten/Behalt.

Ordine nr: **VS ORDINE 535-540**
Bestell-Nr./auftrag/Bestell-Nr.

Tipo di Elaborazione: **E+AOD**
Erzeugungsweg/Herstellungsweg/Erzeugungsweg

CERTIFICATO DI COLLAUDO ABNAHMEPRUEFZEUGNIS INSPECTION CERTIFICATE CERTIFICAT DE RECEPTION EN 10204 3.1.B

Certificato nr: **MEST775434/2009**
Prüfung/Zertifikat

Conferma ordine nr: **BS00001521**
Werk/Dat./Bestell-Nr.

Machio di Fabbrica:
Zustand des Lieferwerkes
Trade mark
Eigenschaft/Produkt

Punzione del Collaudatore:
Prüfung/Werkzeugzeug/Begleit
Inspektion/Stamp/Prüfung des/Inspektion



Specifiche

Anforderungen/Requirements/Bedingungen

VAL STOCK 2004 1.4301/304 A
ASME (1) SA182 2001 S30409 A 0
ASME (1) SA479 2001 S30409 A 3
ASTM A278 2000A S30409 A
ASTM A484 2003A
EN 10272 2000 1.4878A
(1) SEC.II P.T.A 2001 EDITION
(2) SEC.II P.T.A 2001 EDITION
(4) Chemical analysis only and mech properties for ASTM A162(M)

AISI 304H
ASME (1) SA193 2001 B8 CLASS 1
ASTM A182 2002 S30409 4
ASTM A320 2003 B8 CLASS 1
DIN 17440 98 1.4878A
NACE MR0175 2002 S30409

1SEC.II P.T.A 2001 EDITION
3SEC.II P.T.A 2001 EDITION

AMS 5639 H S30409 A
ASME (1) SA320 2001 B8 CLASS 1 (2)
ASTM A193 2001A B8 CLASS 1
ASTM A479 2001 S30409 A
EN 10088-3 95 1.4301 A
QQ-S-763 F 304 A

Qualità: **1.4878 MAXIVAL**

Werkstoff/Grade/Name

Marcia: **MVAIS/DE**

Markenbezeichnung/Brand/Name

Punzonatura: **1.4878**

Markierung/Marking/Marking

Pos. nr. Pos. nr. St. de poste	Oggetto Description Description de produit	Dimensioni - mm Abmessungen Dimension	Tolleranza Tolerance Tolérance	Lunghezza - mm Length Langueur	Colata Schmelze Coulée	Pezzi Stückzahl Pièces	Peso - KG Gewicht Poids	Lotto nr. Lose Lot n.
0010	Tondo	38,000	k12	5000 / 8000	9RN6		102,0	317800960

Sono state soddisfatte tutte le condizioni richieste
Die gestellten Anforderungen sind, Anlage erfüllt
The material has been furnished in accordance with the requirements
Le matériel a été livré conforme aux exigences

Controllo antiriscaldamento: OK
Vorwärmprüfung/Sperrtemperaturüberprüfung
Annealing testing performed: OK
Control antiriscaldamento OK

Controllo visivo e dimensionale: soddisfa le esigenze
Bechtigung und Ausmessung: sind Bestanden
Visual inspection and dimensional check satisfactory
Control visuel et dimensionnel satisfaisant

TEST ALLO STATO DI FORNITURA														
Test on delivery condition Prüfung auf lieferbaren Produkt Test à l'état de livraison Prova sobre el material así como entregado														
TEST	Prova/Prüfung Lap Test/Probe Kübel Probe Nägel Probe Lap Test/Probe Lap Test/Probe	°C	Prova/Prüfung Tensile Tensile	Stranovanje Tensile Tensile	Resistenza Tensile Tensile	Allungamento Elongation Elongation		Strizione Reduction Reduction		Resilienza Resilience Resilience	Durezza Hardness Hardness			
			Rp 0,2% N/mm ²	Rp 1% N/mm ²	Rm N/mm ²	A5 %	E4d %	Z %	RA %	KV J	HB			
Valori richiesti / Inforamtionen/Bedingungen Vorschlagswerte		min max	207	230	617 700	45	40	-	50	100	- 215			
A	10.00	20	L	315	374	609	50	59	71	71	227	238	232	187

TEST	min	max
Dimensioni grano x ASTM E112		6

1%-Inghedra/Wärme, T-Innenrohr, G-Temperaturspeicher

Analisi chimica

Chemische Zusammensetzung/Chemical Analysis/Analyse chimique

Colata/Abt./Coulée	Werk- max 0,005	1,00	2,00	15,00 15,00	1,00	1,00	8,00 10,00	0,040	0,030	0,100	-	-	-	-
	C %	Si %	Mn %	Cr %	Mo %	Cu %	Ni %	P %	S %	N %				
9RN6	0,047	0,71	1,69	18,05	0,41	0,43	8,55	0,024	0,023	0,002				

Corrosion test per EN ISO 3681-2A sensitized T1 : OK

Melted and manufactured in Italy No welding or weld repair Material free from Mercury contamination

We declare that the finished product is checked for radioactive contamination through Pedal System when it leaves the production plant,
The Quality Management System is Certified according to Pressure Equipment Directive (2002/95/EC) Annex 1, 4, 5 by TÜV and Lloyd's

PRESA DI PRESSIONE
1/4" APT-F

TECNOMATIC S.p.A.
Quality Control
WITNESSED REVIEWED
Date: 27/04/10
Signature: _____

Bolzano, 31/07/09 MEST004 (Mod. MEST0)	Il collaudatore di stabilimento / der Werkssachverständiger / Works Inspector / L'agent d'essai M. Rizzi	Pagina - 1 di 1
--	--	-----------------

**Tecno Saldo Pavese** s.n.c.
 CONTROLLI NON DISTRUTTIVI
 Loc. Fabbrica 27040 Arena Po (PV)
 Tel. 0385/263350 Fax 0385/272802
 Cod. Fisc./P.IVA: 00333080331

RAPPORTINO RADIOGRAFICO
RADIOGRAPHIC REPORT

RR 1150/10

 PAGINA 1 DI 1
 PAGE OF 1

 CLIENTE - CUSTOMER **TM-TECNOMATIC SPA** ORDINE - ORDER _____ COMMESSA - JOB _____

 POS. - ITEM _____ MATERIALE - MATERIAL **AINI 304** CONDIZIONI SUPERFICIALI - SURFACE CONDITIONS **AS WELDED**

 SPECIFICA GENERALE - GENERAL SPECIFICATION **ASME V ART.2 ASME VIII DIV.1 PAR.UW51** SPECIFICA CLIENTE - CUSTOMER SPECIFICATION _____ DISEGNO - DRAWING **N**

 OGGETTO - OBJECT **TUBO VENTURI ISO 5167 2° ANSI 2500** NOTE _____

Condizione dell'esame - examination conditions

TIPO SORGENTE SOURCE TYPE	<input checked="" type="checkbox"/> RX <input type="checkbox"/> R 1192
NOME FABBRICANTE TRADE NAME	GILARDONI 300MHFD
MACCHIA FOCIALE FOCAL SPOT	1,5X1,5
SPESORE PENETRATED THICKNESS	9,5 mm.
ENERGIA ENERGY	200 Kv.
TEMPO ESPOSIZIONE EXPOSURE TIME	1'35" 6ma.
DISTANZA FOCIALE FOCAL DISTANCE	700 mm.
PENETRAMENTO PENETRIMETER	ASTM 1A
LATO FILM FILM SIDE	<input type="checkbox"/> LATO SORGENTE SOURCE SIDE <input checked="" type="checkbox"/>
SPES. COMP. SPM N.A.	TIPO FILM FILM TYPE AGFA D4
FILM SINGOLO SINGLE FILM	<input checked="" type="checkbox"/> FILM DOPPIO DOUBLE FILM <input type="checkbox"/>
PARETE SINGOLA SINGLE WALL	<input type="checkbox"/> PARETE DOPPIA DOUBLE WALL <input checked="" type="checkbox"/>
SCHERMO ANT. FRONT SCREEN	Spess. 0,10 mm THICK 0,10 mm
SCHERMO POST. BACK SCREEN	Spess. 0,15 mm THICK 0,15 mm
FORMATO PELLICOLA FILM SIZE	10X24

SVILUPPO AUTOMATICO - DEVELOPMENT AUTOMATIC

TECNICA DI RIPRESA - RADIOGRAPHIC TECHNIQUE

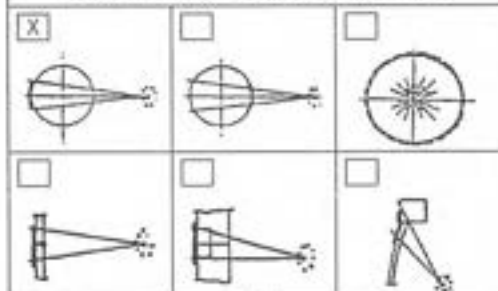

A	INCLUSIONI GASSOSE GAS BUBBLES	L	DEFETTO ALL'INCROCIO FAULT OF JUNCTION OF SEAM
B	POROSITA' POROSITY	M	MANCANZA DI FUSIONE LACK OF FUSION
C	TARLI PIPES	N	MANCANZA DI PENETRAZIONE INCOMPLETE PENETRATION
D	INCLUSIONI DI SCORIA SLAG INCLUSIONS	O	CRICCA CRACKS
E	INCLUS. POLIGONALI INCLUSIONS OF ANY SHAPE	P	CRICCA LONGITUDINALE LONGITUDINAL CRACKS
F	INCLUS. ALLINEATE SLAG LINES	Q	CRICCA TRASVERSALE TRANSVERSE CRACKS
G	INCLUS. AD INTERVALLI WEAVING FAULTS	R	INDIZIONE UNDERCUTTING
H	DEFETTO DI PALIZZA FAULT FROM BAD CHIPPING	S	CORDONE IRRREGOLARE ERRATIC WELD BEAD
I	DEFETTO DI RIPRESA FAULT FROM BAD PASS		

 CONFORME ALLA SPECIFICA CONF. TO SPECIFICATION
 NON CONFORME ALLA SPECIFICA NOT CONF. TO SPECIFICATION

 a) Si dichiara che il certificato riguarda solo i campioni sottoposti a prova.
 We declare that this report refers to the examined parts only.
 b) Si dichiara che il certificato non può essere riprodotto parzialmente, salvo nostra approvazione scritta.
 We declare that this report cannot be partially reproduced without our written approval.

NOTE - REMARKS	DATE - DATE 22/04/2010	OPERATORE - OPERATOR Tecno Saldo Pavese snc	ISPIETTORE DEL CLIENTE CUSTOMER'S INSPECTOR Quality Control
		WITNESSED <input type="checkbox"/>	REVIEWED <input checked="" type="checkbox"/>

LIQUID PENETRANT EXAMINATION (CONTROLLO CON LIQUIDI PENETRANTI)

DESCRIPTION (DESCRIZIONE)

Customer (Cliente)		Order No (Ordine N.)		TM JOB
S.I.E.T.		43-10		PT01/064-R10
Subject (Soggetto)			Plant (Impianto)	
No. 1 TUBO VENTURI 2" ANSI 2500 WN-LF/LM			/	
Doc. N.	Rev.	Step (Fase)	Drawing (Disegno)	Material Type (Tipo di Materiale)
/		/	064.R10.D01	AISI 304
General Specification (Specificazione Generale)		Examination Procedure (Procedura di Esame)		Surface Condition (Condizione Superficiale)
ASME V-VIII / ASTM E 165		TM PROC.01 REV. 0		COME SALDATO

CHEEK (ESAME)

Utilized Products (Prodotti Utilizzati)	Water Washable (Solubile in Acqua)		Post Emulsifiable (Post Emulsionabili)		Solvent Removable (Solubile in Solvente)	
	Visivo (Visible)	Fluorescent	Visivo (Visible)	Fluorescent	Visivo (Visible)	Fluorescent
Cleaner (Pulitore)	SOLVENT					
Penetrant Bath N (Penetrante Bagno N)	VP 30					
Emulsifier (Emulsionatore)	/					
Solvent (Solvente)	/					
(Rivelatore Developer)	D 70					
Trade Mark (Marca Fabbricante)	NDT					

Precleanin (Pre Pulizia)	BY BRUSCHING	Dryparts (Essiccazione)	NORMAL EVAP.
Penetrant Application (Applic.Penetr)	SPRAY	Minimum Penetrant Time (Tempo Penetr/Minim)	15 MINUTES
Penetrant Removal (Rimoz/Penetr)	BY WATER	Emulsification Application (Applic/Emulsific)	/
Developing Application (Applic/Svilupp)	SPRAY	Minimum Developing Time (Tempo Min/Svilupp)	7 MINUTES
Black Light Intensity (Lungh/Onda Luce)	/	Test Temperature (Temperatura di Prova)	18°C
Max Reading Time (Tempo Max Lettura)	30 MINUTES	Post-Cleaning (Pulizia dopo Controllo)	BY SOLVENT

SKETCH OF WORKPIECE AND DISCONTINUITY INDICATION (SCHIZZO DEL PEZZO E DISCONTINUITÀ)

	DISCONTINUITY
	NESSUNA INDICAZIONE

RESULT (RISULTATO)

<input checked="" type="checkbox"/> Conforming (Conforme)	<input type="checkbox"/> Not Conforming (Non Conforme)	<input type="checkbox"/> Repair (Riparare)	<input type="checkbox"/> Reject (Scarto)
Notes			
LIQUIDI PENETRANTI ESEGUITI SULLE SALDATURE D'ANGOLO			

Examination Performed by (Esame eseguito da)	Purchaser's Inspector (Ispettore Cliente)	Authorized Inspector (Ispettore Ente Autorizzato)
 TECNOMATIC S.p.A. LIVELLO / Level II EN - 473 (D. Mastarvesti)		
Date (Data) 23/04/2010	Date (Data)	Date (Data)

tecnomatic® S.p.a
CREMONA - ITALY



Dichiarazione di Conformità
Declaration of Conformity
Declaration de Conformité

La Ditta TM TECNOMATIC S.p.a
The Company

Dichiara con la presente la conformità del Prodotto
Herewith declares conformity of the Product

TUBO VENTURI 2" ANSI 2500 WN-LF/LM

S/N 064-R10/1

DN 2" ANSI 2500 WN- LF/LM	PS 173 barg	P.T. 260 barg	T. 0 / +330°C
Fluido: ACQUA	Stato del fluido: LIQUIDO	Gruppo: 2	

In accordo alla Direttiva Europea
In accordance with EC Directive

97/23/CE

Categoria di rischio:
Category of

I

II

III

IV

ARTICOLO 3 COMMA 3

Procedura di valutazione utilizzata:
Conformity assesment procedure

Modulo H

Organismo Notificato:
Notified Organism

Società Consortile PASCAL a.r.l.
Via SCARSELLINI, 13
20161 MILANO

Numero accreditamento ON:
Number of Notified Organism

/

Cremona, 27/04/2010

TECNOMATIC S.p.A.
Il Direttore Generale
The General Manager

 **TM TECNOMATIC SpA**
26100 CREMONA - Via delle Industrie, 36
Tel. +39.0372.21574 Fax +39.0372.28318
Partita IVA 01316980190

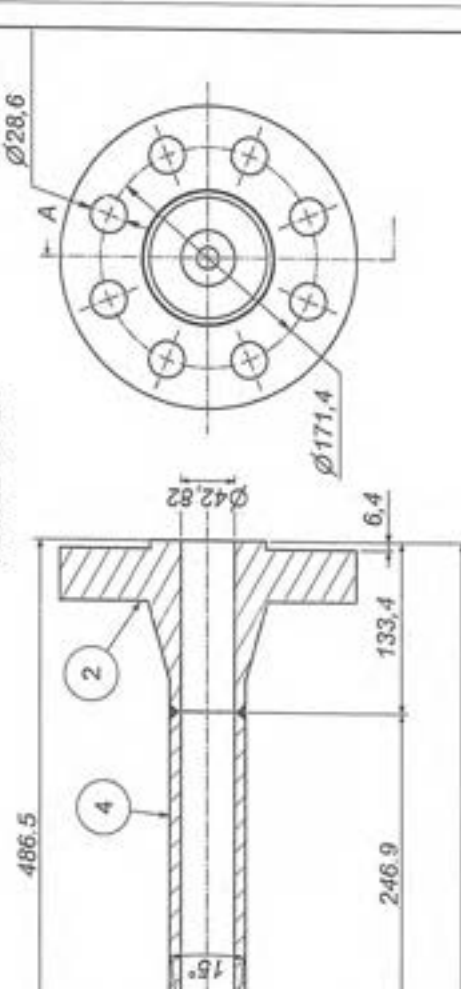
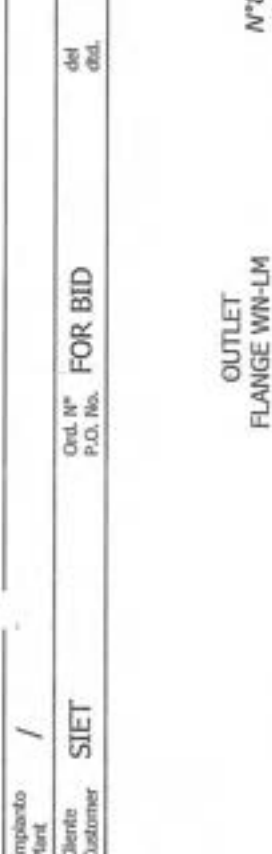

NAMEPLATE DETAIL
 TECNOMATICA SPA CREMONA - ITALY
 Product VENTURI TUBE - 1SD 5167
 SIGLA/TAG / /
 RATING 192° ANSI 2500 WN-LF
 PIPE INSIDE DIAMETER 42.82 mm
 THROAT DIAMETER 17.15 mm
 VENTURI MATERIAL A131 304
 THROAT MATERIAL A131 304
 FLANGES MATERIAL A131 304
 FLOW DIRECTION

NOTES:
 -RX EXAMINATION ON CIRCUMFERENTIAL WELDS
 -PENETRANT TEST ON FILLET WELDS
 -HYDROSTATIC TEST AT 1,5 TIMES OF DESIGN PRESSURE
 (PED 97/23/CE Certification)

Code N° / Code No.	TV278QDB60013101	Scale Scale	
	N/A - Default	Prodotto Prodotto	
		Prodotto Prodotto	
		N° Part Qty	1
		Page Page	1 of 1
		Commissa N° - Job No.	064-R10.100106
		N° Dis. - Draw No.	064-R10.D01
			CREMONA ITALY

Item	Qty	Description	TM Tecnomatic Code	Material
5	1	PRESSURE TAPS ND 1/4" NPT-M 5.000		AISI 304
4	2	PIECES OF PIPE ND 2" SCH. 160		AISI 304
3	1	FLANGE ND 2" ANSI 2500 WN-LM		AISI 304
2	1	FLANGE ND 2" ANSI 2500 WN-LF		AISI 304
1	1	BODY VENTURI		AISI 304

4					
3					
2					
1					
0					
1					

TUBO VENTURI SPECIALE
 DN 2" ANSI 2500
 WN-LF / WN-LM

Allegato 7:

Lista materiali certificati: Disegno 074-00-01rev3 tav. 7,
tronchetto a valle venturimetro

Assieme

IMPIANTO PROVA BARRE

N°Riferimento Disegno

074.00.01

Rev.:

3

Tav. 8 rev .2

Data:

28/06/2010

Part. N°	Descrizione	Quantità	Lunghezza (mm)	Materiale	N° Certificato	Data Certificato	Fabbricante	N° di colata	Note
4	Flangia WN 2" ansi 2500 LF	1	-	ASTM A182 F304	53/10-1	29/04/'10	Steeltrade	379250	
4a	Flangia WN 2" ansi 2500 RJ	1	-	ASTM A182 F304	53/10-3	30/04/'10	Steeltrade	379250	
43c	Flangia WN 1" ansi 2500 LF	1	-	ASTM A182 F304	53/10-1	29/04/'10	Steeltrade	508471	
64/1	Curva 90° LR 2" sch. 160	1	-	ASTM WP 316	20100 128-2	28/01/'10	Lixue Group	TG080059	
64/2	Tee rid. 2"x 1/2" SW s. 6000	1	-	SA182 F304	00696/001	08/04/'10	OMSA	873477	
64/3	Curva 90° LR 1/2" sch. 80	2	-	ASTM WP 316	2010 0128-4	28/01/'10	Lixue Group	TG090121	
64/4	Tubo 1/2" sch.80	2	125	ASTM AISI 304	417490	19/12/'08	T.T.I. Tubacex	40405	
64/5	Tubo 2" sch.160	1	1367	ASTM AISI 304	428723	06/10/'09	T.T.I. Tubacex	41544	
64/6	Tubo 3/8" sch.80	1	2368	ASTM AISI 304	121833	19/01/'07	Schoeller-Bleckmann	40405	
64/7	Tee 3/8" SW s. 9000	1	-	SA182 F316	01540/001	19/10/'04	Olarra	834739	
64/8	Tubo 3/8" sch.80	1	725	ASTM AISI 304	121833	19/01/'07	Schoeller-Bleckmann	40405	
64/9	Riduzione concentrica (swage) 3/8" x 1" sch. 80	1	-	SA182 F304	00696/001	08/04/'10	OMSA	972190	

Compilato da:



Data:

28/06/2010

CERTIFICATE OF CHEMICAL ANALYSIS AND MECHANICAL TEST.



STEELTRADE s.r.l.
 Loc. CATTAGNINA
 29010 ROTTOFRENO (PC) - ITALY
 TEL. +39 0523 780121
 FAX +39 0523 780123
 E-mail: inspection@steeltrade.it
 WEB: http://www.steeltrade.it

CERTIFICATE N. :53/10-1
 DATED :29/04/10

PURCHASER : SIET

YOUR ORDER : 74-10

JOB N. : ST 53/10

ITEM	Q.TY N°	DESCRIPTION	MATERIAL	HEAT CODE	HEAT
ITEM 01	4	WN FLANGE 1" LARGE MALE SCH.80 ANSI 2500	ASTM A182 F304	0B3	374150
ITEM 02	6	WN FLANGE 1" LARGE FEMALE SCH.80 ANSI 2500	ASTM A182 F304	B540	508471
ITEM 03	1	SLIP ON FLANGE 3" RF CL150	ASTM A182 F304	B248	259170
ITEM 04	1	SLIP ON FLANGE 2" RF CL150	ASTM A182 F304	B140	21728
ITEM 05	1	BLIND FLANGE 3" RF CL600 FORATA DIAM. 61 mm	ASTM A182 F304	B254	444625
ITEM 06	1	BLIND FLANGE 2" RF CL150 FORATA DIAM. 34 mm	ASTM A182 F304	B266	D82126A
ITEM 07	8	WN FLANGE 2" LARGE MALE SCH.160 ANSI 2500	ASTM A182 F304	B500	379250
ITEM 08	9	WN FLANGE 2" LARGE FEMALE SCH.160 ANSI 2500	ASTM A182 F304	B500	379250
ITEM 09	1	WN FLANGE 3/4" LARGE MALE SCH.160 ANSI 2500	ASTM A182 F304	B273	291450
ITEM 10	1	WN FLANGE 3/4" LARGE FEMALE SCH.160 ANSI 2500	ASTM A182 F304	B273	291450

Chemical Analysis

HEAT	C%	Mn%	Si%	P%	S%	Mo%	Cr%	Ni%	V%	Cu%	Ti%	Nb%	C.eq% *
374150	0.023	1.78	0.35	0.0028	0.0021		18.43	8.91					
508471	0.009	1.12	0.40	0.028	0.0026		18.14	9.12					
259170	0.014	1.75	0.31	0.026	0.024		18.33	8.14					
21728	0.017	0.77	0.32	0.028	0.002		18.25	9.20					
444625	0.013	1.10	0.41	0.026	0.026		18.20	9.22					
D82126A	0.019	1.61	0.42	0.025	0.025		18.26	10.17					
379250	0.022	1.71	0.24	0.03	0.021		18.22	8.93					
291450	0.022	1.76	0.31	0.029	0.026		18.32	8.20					

Mechanical Properties

HEAT	TENSILE TEST					IMPACT TEST					
	Tensile strength N/mm2	Yield point N/mm2	Elongation 2" %	Red. of Area %	Hardness HB	Type	Section	Temp.	Values J	Values J	Values J
374150	606	341	47.2	60.3							
508471	549	348	52.6	74.8							
259170	582	241	61.0	70.4							
21728	525	375	49.0	73.0							
444625	577	278	57.0	69.0							
D82126A	576	242	53.0	71.0							
379250	576	281	57.0	72.6							
291450	580	274	59.7	75.0							

NOTE:

- CERTIFICATE CONFORM TO : EN 10204.3.1
- STEEL MADE BY ELECTRIC FURNACE
- HEAT TREATMENT : SOLUTION ANNEALED
- ACCORDING TO PED 97/23/EC ANNEX 1 PAR.4.3
- PMI : NO OBJECTION (100% TESTED WITH NITON ANALYZER)
- DIMENSIONS : ASME B16.5
- VISUAL AND DIMENSIONAL TEST : SATISFACTORY

Quality Control
STEELTRADE



*C. eq. by long formula

The present certificate is in fully accordance with UNI CEI EN 45014-90

CERTIFICATE OF CHEMICAL ANALYSIS AND MECHANICAL TEST.



STEELTRADE s.r.l.
 Loc. CATTAGNINA
 29010 ROTTOFRENO (PC) - ITALY
 TEL. +39 0523 780121
 FAX +39 0523 780123
 E-mail: inspection@steeltrade.it
 WEB: http://www.steeltrade.it

CERTIFICATE N. :53/10-3
 DATED :30/04/10

PURCHASER : SIET

YOUR ORDER : 115-10

JOB N. : ST 53/10

ITEM	Q.TY N°	DESCRIPTION	MATERIAL	HEAT CODE	HEAT
1	2	WN FLANGE 2" RJ WT 8,74 mm SCH.160 CL.2500	ASTM A182 F304	B500	379250

Chemical Analysis

HEAT	C%	Mn%	Si%	P%	S%	Mo%	Cr%	Ni%	V%	Cu%	Ti%	Nb%	C.eq%*
379250	0.022	1.71	0.24	0.03	0.021		18.22	8.93					

Mechanical Properties

HEAT	TENSILE TEST					Hardness HB	IMPACT TEST						
	Tensile strenght N/mm2	Yield point N/mm2	Elongation 2" %	Red. of Area %	Type		Section	Temp.	Values J	Values J	Values J		
379250	576	281	57.0	72.6									

NOTE:

- CERTIFICATE CONFORM TO : EN 10204.3.1
- STEEL MADE BY ELECTRIC FURNACE
- HEAT TREATMENT : SOLUTION ANNEALED
- ACCORDING TO PED 97/23/EC ANNEX 1 PAR.4.3
- PMI : NO OBJECTION (100% TESTED WITH NITON ANALYZER)
- DIMENSIONS : ASME B16.5
- VISUAL AND DIMENSIONAL TEST : SATISFACTORY

Quality Control
STEELTRADE



*C. eq. by long formula

The present certificate is in fully accordance with UNI CEI EN 45014-90

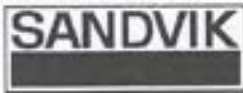

CertificateNo

128-2

1(2)

Date

2010-04-06

Riferimenti del cliente

Indirizzo del cliente

SIG.MARINELLI
R.T.I. SPA
VIA AMBROSOLI 2/A
20090 RODANO MILLEPINI MI
Italy

Codice prodotto Cliente

FBBLR-304L-2-160

Numero d'ordine

ORD.29527/10 29.3

Riferimenti di Sandvik

Codice prodotto Sandvik

FBBLR-304L-2-160

Lunghezza

Lotto

Colata

TG080059

Quantità consegnata

3 Pieces

Numero d'ordine del cliente

255501

Linea d'ordine del cliente

4

DDT Nr

15900



LIXUE GROUP CO.,LTD.

TINGTIAN INDUSTRIAL ZONE, RUIAN CITY, ZHEJIANG CHINA

MILL TEST CERTIFICATE ACCORDING TO EN 10204./3.1+PED 97/23/EC

ISO9001:2000

Client		Santrade Ltd				Certificate No		20100128-2				
Contract NO		GF20091217				Delivery Conditions		Solution Annealed, pickled and passivated				
Product		STAINLESS STEEL COLD FORMED BUTT WELD FITTINGS				Specification		ASTM/ASME A/SA 403-06 ANSI B16.9-07				
Item	Quantity	Size		Description		Grade	Heat No.	Heat treatment	Quenching			
2	300	1"	SCH10S	Long Radius Elbows 90°		WP304/304L-S	00910202	1052° 15 min.	RWQ			
10	20	2"	SCH160	Long Radius Elbows 90°		WP304/304L-S	TG080059	1052° 15 min.	RWQ			
14	100	3/4"	SCH80S	Long Radius Elbows 90°		WP304/304L-S	LH08-4022	1052° 15 min.	RWQ			
15	150	1/2"	SCH10S	Long Radius Elbows 90°		WP316/316L-S	TG080131	1052° 15 min.	RWQ			
17	100	1 1/4"	SCH10S	Long Radius Elbows 90°		WP316/316L-S	YT090227	1052° 15 min.	RWQ			
20	150	3"	SCH40S	Long Radius Elbows 90°		WP316/316L-S	TG090482	1052° 15 min.	RWQ			
23	20	4"	SCH160	Long Radius Elbows 90°		WP316/316L-S	TG090607	1052° 15 min.	RWQ			
chemical composition (%)												
Heat No.	C	Mn	P	S	Si	Cr	Ni	Mo	Ti			
00910202	0.030	1.86	0.033	0.002	0.280	18.30	8.19					
TG080059	0.027	0.82	0.039	0.002	0.540	18.11	8.07					
LH08-4022	0.016	0.85	0.034	0.009	0.52	18.39	8.15					
TG080131	0.025	0.77	0.039	0.001	0.430	18.58	11.06	2.08				
YT090227	0.022	0.78	0.038	0.003	0.380	16.67	10.08	2.08				
TG090482	0.024	0.86	0.040	0.003	0.390	16.70	10.06	2.07				
TG090607	0.021	0.85	0.039	0.002	0.440	16.76	10.09	2.08				
Mechanical Properties					NACE MR0175	IC Test ASTM A262E	Impact Test	Non-destructive Test		PMI	Visual	Dimensional
Heat No.	TS(Mpa)	YS (Mpa)	EL(%)	Hardness				PT				
00910202	534	255	62	HRB<=90	OK	OK	N/A	OK	OK	OK	OK	
TG080059	560	245	60	HRB<=90	OK	OK	N/A	OK	OK	OK	OK	
LH08-4022	615	305	50	HRB<=90	OK	OK	N/A	OK	OK	OK	OK	
TG080131	575	265	60	HRB<=90	OK	OK	N/A	OK	OK	OK	OK	
YT090227	535	225	62	HRB<=90	OK	OK	N/A	OK	OK	OK	OK	
TG090482	575	255	60	HRB<=90	OK	OK	N/A	OK	OK	OK	OK	
TG090607	560	260	57	HRB<=90	OK	OK	N/A	OK	OK	OK	OK	
MARKINGS: LIXUE - SPEC - SIZE - SCH - GRADE - HEAT NO												
Materials have been manufactured in complete accordance with the purchasers order												
The melting process: Electric arc furnace												
PO NO: 24110												

Signed:
 Date: 2010.01.28

QUALITY ASSURANCE APPROVAL
Q.A. Manager
02. März 2010
SANTRADE LTD LUCERNE



SANTRADE ITALIA S.p.A.
REVIEWED

CHEMICAL ANALYSIS AND MECHANICAL TEST CERTIFICATE TO: DIN 50049 3.1 - EN 10204/3.1

Messrs. R.T.I. SPA VIA AMBROSOLI 2/A 20090 RODANO MILLEPINI MI	ORDER: 29525/10 DATE : 29/03/2010 JOB : 10/91 /00895
---	--



omsa S.R.L.

OFFICINE INGEGNERIE SOLBIATE ARNO

Sede e Stabilimento: 21048 SOLBIATE ARNO (Varese)
Via Caronno Varese
Tel. +39.0331.594.216 - Fax +39.0331.591.798
web: http://www.omsafinding.it - e-mail: info@omsafindings.it



ITEM	Q.TY	DESCRIPTION	MATERIAL	HEAT CODE	STEEL MLL	MLL CERT	HEAT N.
1	1,00	TEE S.6000 2*X3/4" SW F304L	SA182F304/304L	M416	COONE	2009005078	873477
2	2,00	TEE S.6000 2*X1/2" SW F304L	SA182F304/304L	M416	COONE	2009005078	873477
3	1,00	TEE S.6000 2*X1" SW F304L	SA182F304/304L	M416	COONE	2009005078	873477
4	2,00	GOMITO 90 S.3000 3/8" SW F304L	SA182F304/304L	D75	GLARRA	421.058	962852
5	1,00	SWAGE XS 1*X3/8" F8E F304L	SA182F304/304L	E87	COONE	2009037018	972199
6	1,00	MANICOTTO 1000 2" ISO7 RP F304L	SA182F304/304L	M463	ACC. VALBRUNA	HEST780643/2009	247190
7	1,00	MANICOTTO 1000 1.1/4" ISO7 RP F304L	SA182F304/304L	M476	ACC. VALBRUNA	802704/2009	423100

CHEMICAL ANALYSIS

HEAT CODE	C %	Mn %	Si %	P %	S %	Ni %	Cr %	Mo %	Ti %	Al %	V %	Cu %	Nb %	N %	C.E. %	NOTE
M416	0,020	1,290	0,330	0,032	0,030	8,060	18,120	0,430	0,000	0,000	0,000	0,330	0,000	0,077	0,000	0,000
M416	0,020	1,290	0,330	0,032	0,030	8,060	18,120	0,430	0,000	0,000	0,000	0,330	0,000	0,077	0,000	0,000
M416	0,020	1,290	0,330	0,032	0,030	8,060	18,120	0,430	0,000	0,000	0,000	0,330	0,000	0,077	0,000	0,000
D75	0,024	1,550	0,360	0,034	0,027	8,050	18,050	0,000	0,000	0,000	0,000	0,000	0,000	0,083	0,000	0,000
E87	0,024	1,350	0,370	0,032	0,027	8,060	18,080	0,390	0,000	0,000	0,000	0,300	0,000	0,092	0,000	0,000
M463	0,018	1,800	0,630	0,029	0,030	8,220	18,010	0,490	0,000	0,000	0,000	0,470	0,000	0,088	0,000	0,000
M476	0,016	1,770	0,590	0,026	0,025	8,170	18,270	0,430	0,000	0,000	0,000	0,500	0,000	0,088	0,000	0,000

MECHANICAL TEST

HEAT CODE	R N/mm ²	S N/mm ²	A %	C %	Bending Test	Flattenin g	Hydraulic Test	HARDNESS HB	IMPACT TEST J - °C	HEAT TREATMENT - °C	NOTE
M416	607,0	275,0	57,0	74,0				178 178		SOLUTION AT 1050	
M416	607,0	275,0	57,0	74,0				178 178		SOLUTION AT 1050	
M416	607,0	275,0	57,0	74,0				178 178		SOLUTION AT 1050	
D75	623,0	319,0	54,0	73,0				170 170		SOLUTION AT 1050	
E87	613,0	263,0	57,8	74,0				178 178	285 289 290 20	SOLUTION AT 1050	
M463	615,0	308,0	62,0	70,0				181 181		SOLUTION AT 1050	
M476	661,0	399,0	47,0	74,0				190 190	224 229 221 20	SOLUTION AT 1050	

WE HEREBY CERTIFY THAT THE ABOVE IS IN ACCORDANCE WITH THE ORIGINAL CERTIFICATE WHICH IS HELD BY US.
SPECIMEN FOR ELONGATION: STANDARD ROUND. FITTINGS MEET ANSI B16.11 & B31.99 REQUIREMENTS.UNIONS GROUND JOINT, STEEL TO STEEL
FITTINGS ARE DIMENSIONAL AND SURFACE CHECKED WITHOUT OBJECTION. C/SWADES AND PIPE NIPPLES SEAMLESS.
MATERIAL TO ASME Sec.II Part A Ed.2007 - ASTM 01.01 MACE MR01.75 MR01.03 LATEST EDITION. A105N NORMALISED AT 890 C.
IN ACCORDANCE WITH PED 97/23/EC ANNEX 1 SECT. 4.3, WHERE REQUIRED EDDY CURRENT OR HYDROSTATIC TEST WITHOUT OBJECTIONS.
ASTM A182 F11 NORM. AT 920 C. O'LET TO MSS SP97.

INSPECTION	O.M.S.A. S.R.L. Quality Assurance Manager (Davide Foschini) <i>Davide Foschini</i>	CERTIFICATE N° 00494/001	DATE 08/04/2010
------------	---	-----------------------------	--------------------

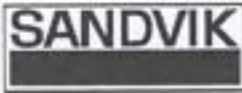

CertificateNo

128-4

1(2)

Date

2010-04-06

Riferimenti del cliente

Indirizzo del cliente

SIG.MARINELLI
R.T.I. SPA
VIA AMBROSOLI 2/A
20090 RODANO MILLEPINI MI
Italy

Codice prodotto Cliente

FBBLR-304L-1/2-80S

Numero d'ordine

ORD.29527/10 29.3

Riferimenti di Sandvik

Codice prodotto Sandvik

FBBLR-304L-1/2-80S

Lunghezza

Lotto

Colata

TG090121

Quantità consegnata

2 Pieces

Numero d'ordine del cliente

255501

Linea d'ordine del cliente

5

DDT Nr

15900



LIXUE GROUP CO.,LTD.

TINGTIAN INDUSTRIAL ZONE, RUIAN CITY, ZHEJIANG CHINA
MILL TEST CERTIFICATE ACCORDING TO EN 10204./3.1+PED 97/23/EC

ISO9001:2000

Client		Santrade Ltd			Certificate No		20100128-4				
Contract NO		GF20100106			Delivery Conditions		Solution Annealed ,pickled and passivated				
Product		STAINLESS STEEL COLD FORMED BUTT WELD FITTINGS			Specification		ASTM/ASME A/SA 403 -06 ANSI B16.9-07				
Item	Quantity	Size		Description	Grade	Heat No.	Heat treatment	Quenching			
1	200	1/2"	SCH10S	Long Radius Elbows 90°	WP304/304L-S	06V0013	1052° 15 min.	RWQ			
2	150	1/2"	SCH80S	Long Radius Elbows 90°	WP304/304L-S	TG090121	1052° 15 min.	RWQ			
5	100	1"	SCH80S	Long Radius Elbows 90°	WP304/304L-S	LH08-4022	1052° 15 min.	RWQ			
6	500	2"	SCH10S	Long Radius Elbows 90°	WP304/304L-S	SLA090320-7	1052° 15 min.	RWQ			
7	50	2"	SCH80S	Long Radius Elbows 90°	WP304/304L-S	SLA090320-7	1052° 15 min.	RWQ			
9	100	3"	SCH10S	Long Radius Elbows 90°	WP304/304L-S	TG090650	1052° 15 min.	RWQ			
chemical composition (%)											
Heat No.	C	Mn	P	S	Si	Cr	Ni	Mo	Ti		
06V0013	0.016	1.07	0.032	0.003	0.42	18.43	8.35				
TG090121	0.022	0.77	0.040	0.002	0.410	18.11	8.08				
LH08-4022	0.016	0.85	0.034	0.009	0.52	18.39	8.15				
SLA090320-7	0.022	1.04	0.033	0.002	0.410	18.19	8.07				
SLA090320-7	0.022	1.04	0.033	0.002	0.410	18.19	8.07				
TG090650	0.026	0.84	0.038	0.001	0.470	18.24	8.07				
Mechanical Properties					NACE MR0175	IC Test ASTM A282E	Impact Test	Non-destructive Test	PMI	Visual	Dimensional
Heat No.	TS(Mpa)	YS (Mpa)	EL(%)	Hardness				PT			
06V0013	570	275	60	HRB<90	OK	OK	N/A	OK	OK	OK	OK
TG090121	575	255	62	HRB<90	OK	OK	N/A	OK	OK	OK	OK
LH08-4022	625	255	55	HRB<90	OK	OK	N/A	OK	OK	OK	OK
SLA090320-7	555	260	58	HRB<90	OK	OK	N/A	OK	OK	OK	OK
SLA090320-7	565	255	60	HRB<90	OK	OK	N/A	OK	OK	OK	OK
TG090650	577	288	60	HRB<90	OK	OK	N/A	OK	OK	OK	OK
MARKINGS: LIXUE - SPEC - SIZE - SCH -GRADE- HEAT NO											
Materials have been manufactured in complete accordance with the purchasers order											
The melting process: Electric arc furnace											
PO NO: 24135											

Signed: Date: 2010.01.28

Q.A.Manager



~~SANDVIK-ITALIA S.p.A.~~
REVIEWED

QUALITY ASSURANCE APPROVAL
02 März 2010
SANTRADE LTD LUCERNE



T.T.I. - Tubacex Tubos Inoxidables, S.A.

Registro Mercantil de Alava, Tomo 587, Folio 188, Hoja VI 2888 - N.I.F. A-41140227

Printed
19.01.

INSPECTION CERTIFICATE

EN 10204 3.1

Number: 417490
Page: 1 / 2

Rev: 6

Date: 19.12.2008

19.12.2008

CUSTOMER : PO : C02647 OUR REFERENCE: J9378
 STANDARD : DIN 17450 PK1/EN 10216-5 TC1 AD-2000 W2/W10/TRD100
 ADDIT. SPECS : NACE MR01.75-03 / ISO 15156
 GRADE : 1.4301/1.4306
 DIMENSIONS : 21,34 X 3,73
 MATERIAL : SEAMLESS STAINLESS STEEL TUBE
 COLD ROLLED; PASSIVATED;
 FLAIN ENDS SQUARE CUT;

---ITEM---	---HEAT---	NO. OF	---WEIGHT---	---TOTAL LENGTH---	---UNIT LENGTH---
YOUR	TTI.	PIECES	KG		
	3 40405	113	1152	686,90	5,5 - 6,5 MT

RAW MATERIAL

MELTING PROCESS: ELECTRIC FURNACE + A.O.D FROM: ACERALAVA
 PEELED BARS; MACROETCH TESTING: GOOD;

CHEMICAL COMPOSITION (*1 L: LADLE; C: PRODUCT)

*1 HEAT	C	Mn	Si	P	S	Ni	Cr	Cu	B	N
L 40405	0,012	1,49	0,290	0,032	0,0010	10,15	18,25	0,34	0,0009	0,0720



HEAT TREATMENT

SOLUTION ANNEALED 1100 °C HOLDING TIME >=1.5 MIN/MM WATER QUENCHED

= TESTS =		-----TENSION-----				--IMPACT TESTS--		HARDNESS			
NR.	TEST	T(°C)	MPA	R _m	R _p 0,2	R _p 1,0	A	Z	T(°C) MINIMUM	AVERAGE	HRB
40405	813809	20	603,0	303,0	345,0	58,8					85 86

TECHNOLOGICALS

FLATTENING TEST: GOOD
 FLARING TEST: GOOD
 RING EXPANDING TEST: GOOD

METALLURGICAL TEST

INTERGRANULAR CORROSION: A.262 PRACT. "E" / ISO 3651-2 : NOT OBJECTIONS

NON DESTRUCTIVE TEST

100 % HYDROSTATIC PRESSURE TESTED AT 80 BAR , DURING 6 SEC, GOOD
 STEEL GRADE CHECKING ON EACH TUBE BY SPECTROMETRY (PMI): SATISFACTORY
 DIMENSIONAL CHECKING ON EACH TUBE, SATISFACTORY
 VISUAL INSPECTION ON EACH TUBE, SATISFACTORY

OTHER MATERIAL SPECIFICATIONS

A-SA312M-06 ED.07/NF A49117-85 TP304-304L/Z2-Z6 CN 18.10-09

MARKS

TX2
 TUBACEX 21,34 X 3,73 1.4301-1.4306 H S 1 - EN 10216-5 TC1 1.4301-1.4306 CFD - NF A49-117 Z2-Z6 CN 18.10-09 - A-SA 312 TP304-304L SMUS
 HEAT/..... PMI TX2 SPAIN

REMARKS

TOL ISO T32 D3/T3
 MATERIAL MANUFACTURER APPROVED WITH CERTIFICATE NR. 07/2001/MUC BY TÜV SÜDDEUTSCHLAND (NOTIFIED BODY 0036) TO ISSUE CERTIFICATES OF SPECIFIC PRODUCT CONTROL IN ACCORDANCE WITH PRESSURE EQUIPMENT DIRECTIVE 97/23/EC ANNEX 1 POINT 4.3. AS PER LETTER DATED 21.08.92 TÜV SÜDWEST DECLINES COUNTERSIGNING MATERIAL CHARACTERISTICS COMPLY WITH POINT 7.5 OF ANNEX I TO PED BY HAVING AN ELONGATION AFTER RUPTURE AT TENSILE TEST NO LESS THAN 14 % AND A BENDING RUPTURE ENERGY AT IMPACT TE



We hereby certify that the material herein described has been manufactured, sampled, tested and inspected in accordance with above standards and specifications and satisfies the order's requirements.
 This certificate is issued by a computerized system and it is valid without original signature. In case the owner of the certificate would release a copy of it, he must accept its conformity to the issued, assuming the responsibility for any misuse of T.T.I., S.A. not allowed use.
 Any forgery or falsification of this certificate shall legally prosecuted.

T.T.I.
 Tubacex Tubos Inoxidables, S.A.

INGENIERIA DE CALIDAD



Juan Alana Zubizar



TUBACEX

T.T.I. - Tubacex Tubos Inoxidables, S.A.

Registro Mercantil de Aleva, Tomo 587, Folio 189, Hoja VI 2005 - N.I.F. A-01148227

Printed on:
19.01.2009

INSPECTION CERTIFICATE

EN 10204 3.1

Number: 417490
Page: 2 / 2

Rev: 0

Date: 19.12.2008

19.12.2008

CUSTOMER : PO : **C02647** OUR REFERENCE: **J9378**
 STANDARD : **DIN 17458 PK1/EN 10216-5 TC1 AD-2000 W2/W10/TRD100**
 ADDIT. SPECS : **NACE MR01.75-03 / ISO 15156**
 GRADE : **1.4301/1.4306**
 DIMENSIONS : **21,34 X 3,73**
 MATERIAL : **SEAMLESS STAINLESS STEEL TUBE**
COLD ROLLED; PASSIVATED;
PLAIN ENDS SQUARE CUT;

ST NO LESS THAN 27 J AT 20°C.

CONFORME ALL'ORIGINALE
RUBIVAL INOX S.R.L.



We hereby certify that the material herein described has been manufactured, sampled, tested and inspected in accordance with above standards and specifications and satisfies the order's requirements.
The certificate is issued by a computerized system and it is valid without original signature.
In case the owner of the certificate would release a copy of it, he must attend its conformity to the issued, assuming the responsibility for any error or T.T.I. S.A. not identical use.
Any forgery or falsification of this certificate shall legally prosecuted.

T.T.I.
Tubacex Tubos Inoxidables, S.A.

INGENIERIA DE CALIDAD

[Signature]
Joni Alzola Zubizarain



T.T.I. - Tubacex Tubos Inoxidables, S.A.

Registro Mercantil de Alava, Tomo 587, Folio 198, Hoja VI 2886 - N.I.F. A-01140227

Printed on:
21.10.2009

INSPECTION CERTIFICATE

EN 10204 3.1

Number: 428723

Page: 1 / 2

Rev: 0

Date: 06.10.2009

06.10.2009

CUSTOMER : PO : **C02989*** OUR REFERENCE: **K0002**
 STANDARD : **EN 10216-5 TC2**
 ADDIT. SPECS : **NACE MR01.75-03 / NACE MR03-03 / ISO 15156-3**
 GRADE : **1.4301/1.4306**
 DIMENSIONS : **60,32 X 8,74**
 MATERIAL : **SEAMLESS STAINLESS STEEL TUBE**
COLD ROLLED; PICKLED-PASSIVATED;
PLAIN BEVELLED ENDS;

ITEM	HEAT	NO. OF	WEIGHT	TOTAL LENGTH	UNIT LENGTH	
YOUR	TTI.	PIECES	KG			
	66	41544	28	1933	172,52	5,5 - 6,5 MT

RAW MATERIAL

MELTING PROCESS: ELECTRIC FURNACE + A.O.D FROM: ACERALAVA
 PEELED BARS; MACROETCH TESTING: GOOD;

CHEMICAL COMPOSITION (*1 L: LADLE; C: PRODUCT)

*1 HEAT	C	Mn	Si	P	S	Ni	Cr	N
L 41544	0,017	1,50	0,300	0,027	0,0010	10,15	18,30	0,0720

HEAT TREATMENT

SOLUTION ANNEALED 1100 °C HOLDING TIME >=1.5 MIN/MM WATER QUENCHED

TESTS		TENSION				IMPACT TESTS		HARDNESS	
NR.	NR.	T(°C)	MPA	RP 0,2	RP 1,0	A	Z	T(°C) MINIMUM AVERAGE	HRB
HEAT	TEST								
41544	908135	20	550,0	321,0	369,0	46,7			81 82
41544	908135A	20	550,0	322,0	369,0	45,3			81 82

TECHNOLOGICALS

FLATTENING TEST: GOOD
 RING EXPANDING TEST: GOOD

METALLURGICAL TEST

INTERGRANULAR CORROSION: A262 "E"/ISO 3651-2/ 5 TEST ACC.MIL-P-1144D+24691/3: GOOD

NON DESTRUCTIVE TEST

100 % U.T TO EN10246-7 (ENT.5%, MIN.0,3MM) , GOOD
 100 % EDDY CURRENT TEST AT E-426 , GOOD
 100 % HYDROSTATIC PRESSURE TESTED AT 80 BAR , DURING 5 SEC, GOOD
 STEEL GRADE CHECKING ON EACH TUBE BY SPECTROMETRY (PMI): SATISFACTORY
 DIMENSIONAL CHECKING ON EACH TUBE, SATISFACTORY
 VISUAL INSPECTION ON EACH TUBE, SATISFACTORY



OTHER MATERIAL SPECIFICATIONS

A/SA312M-08A ED.07 + 08 ADD TP304-304L
 A/SA376M-06 ED.07 + 08 ADD TP304

MARKS

TX2
 TUBACEX 60,32 X 8,74 EN 10216-5 TC2 1.4301-1.4306 CFD ASTM-ASME
 A-SA 312 TP304-304L A-SA 376 TP304 SMLS HEAT/..... PMI TX2
 SPAIN

REMARKS

TOL. ISO 1127 D3-T3 / ASTM A999
 NO WELD REPAIR WAS PERFORMED

COPIA CONFORME ALL'ORIGINALE



We hereby certify that the material herein described has been manufactured, sampled, tested and inspected in accordance with above standards and specifications and satisfies the order's requirements.
 This certificate is issued by a computerized system and it is valid without original signature. In case the owner of this certificate would request a copy of it, he must advise its conformity to the issuer, assuming the responsibility for any unlawful or T.T.I.,S.A. not allowed use.
 Any forgery or falsification of this certificate shall legally prosecuted.

T.T.I.
 Tubacex Tubos Inoxidables, S.A.

INGENIERIA DE CALIDAD

[Signature]
 JON ARBUSA ZUBERO



T.T.I. - Tubacex Tubos Inoxidables, S.A.

Registro Mercantil de Álava, Tomo 587, Folio 188, Hoja VI 2886 - N.I.F. A-61140227

Printed on:
21.10.2009

INSPECTION CERTIFICATE

EN 10204 3.1

Number: 428723
Page: 2 / 2

Rev: 0

Date: 06.10.2009 06.10.2009

CUSTOMER : PO : **C02989*** OUR REFERENCE: **K0002**

STANDARD : **EN 10216-5 TC2**

ADDIT. SPECS : **NACE MR01.75-03 / NACE MR03-03 / ISO 15156-3**

GRADE : **1.4301/1.4306**

DIMENSIONS : **60,32 X 8,74**

MATERIAL : **SEAMLESS STAINLESS STEEL TUBE**
COLD ROLLED; PICKLED-PASSIVATED;
PLAIN BEVELLED ENDS;

MATERIAL MANUFACTURER APPROVED WITH CERTIFICATE NR. 07/2001/MUC BY TÜV SÜDDEUTSCHLAND (NOTIFIED BODY 0036) TO ISSUE CERTIFICATES OF SPECIFIC PRODUCT CONTROL IN ACCORDANCE WITH PRESSURE EQUIPMENT DIRECTIVE 97/23/EC ANNEX 1 POINT 4.3. MATERIAL CHARACTERISTICS COMPLY WITH POINT 7.5 OF ANNEX I TO PED BY HAVING AN ELONGATION AFTER RUPTURE AT TENSILE TEST NO LESS THAN 14 % AND A BENDING RUPTURE ENERGY AT IMPACT TEST NO LESS THAN 27 J AT 20°C.



We hereby certify that the material herein described has been manufactured, sampled, tested and inspected in accordance with above standards and specifications and satisfies the order's requirements.

This certificate is issued by a computerized system and it is valid without original signature. In case the owner of the certificate would release a copy of it, he must assure its conformity to the issued, assuming the responsibility for any untruth or T.T.I.S.A. not allowed use.

Any forgery or falsification of this certificate shall legally prosecuted.

T.T.I.
Tubacex Tubos Inoxidables, S.A.

INGENIERIA DE CALIDAD

[Signature]
Jon Albano Zubizarreta

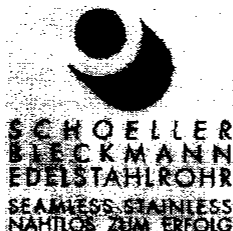

Zertifizierter Hersteller nach DGR 97/23/EG
Certified Manufacturer to PED 97/23/EC
von/by LRQA GmbH
Kennnummer/Identification No.: 0525

ABNAHMEPRÜFZEUGNIS - INSPECTION CERTIFICATE
CERTIFICAT DE RECEPTION PAR L'USINE 3.1 C. C. P. U.
nach / according to OENORM / DIN EN 10 204-3.1



SCHOELLER-BLECKMANN
Edelstahlrohr GmbH
Rohrstrasse 1
A-2630 Ternitz, Austria
Tel: 02630316/601
Fax: 02630316/894

Zert./cert: 121833

Seite/Page: 1 / 4

Datum/Date: 19.01.2007

e-mail: nicole.riegler@sber.co.at

Besteller/Purchaser/Committant

Bestell-Nr./Purchaser's Order No/ No. de commande: 1563

Auftrags-Nr./Works Order No/No. de commande d'usine: 454264 Pos. 30

Erzeugnis/Product/Produit.:

SEAML. STAINL. STEEL TUBES/PIPES,
SBS GRADE A600, 1.4301/1.4306, TP304/TP304L,
FINISH M = COLD FINISHED, BRIGHT ANNEALED,
TECHN. COND. ACC.
ASTM A312/A312M-04B, NACE MR0175/ISO 15156-3:2003,
ASME SECT.II PART.A SA312/SA312M-2004 ED. 2005 ADD,
DIN 17458/07.85 PKL.1, NFA 49-117 SEPT.1985,
EN 10216-5:2004 TEST CATEGORY 1,
CORROSION TESTED TO ASTM A262 PRACTICE E,
DIN 50914/ISO 3651-2 PRACT.A AND NFA 05-159,
TOLERANCES ACC.
ASTM A999/A999M-04A,
ASME SECT.II PART.A SA530/SA530M-2004 ED. 2005 ADD,
FIXED LENGTHS 6.000 MM - 6.000 MM, + 3,0 MM,
PLAIN ENDS,



Ergebnis der Prüfungen/Test Result/Resultat des essais:

Die gestellten Anforderungen sind erfüllt.

The material has been furnished in accordance to the requirements.

Le material a été trouvé conforme aux exigences.

SCHOELLER-BLECKMANN
EDELSTAHLROHR GMBH

Zeichen des Lieferwerks:

Brand of Manufacturer:

Marques de l'usine:

SBS

Zeichen des Prüfers:

Symbol of inspector:

Symbole de l'inspecteur:



Riegler
FR. N. RIEGLER
(DER WERKSACHVERSTÄNDIGE)
(WORKS INSPECTOR/L'EXPERT DE USINE)

COPIA CONFORME ALL'ORIGINALE
RUBIVAL INOX S.R.L.



Zertifizierter Hersteller nach DGR 97/23/EG
 Certified Manufacturer to PED 97/23/EC
 von/by LRQA GmbH
 Kennnummer/Identification No.: 0525

**ABNAHMEPRÜFZEUGNIS - INSPECTION CERTIFICATE
 CERTIFICAT DE RECEPTION PAR L'USINE 3.1 C. C. P. U.
 nach / according to OENORM / DIN EN 10 204-3.1**

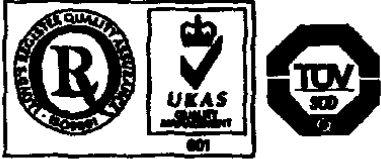

SCHOELLER-BLECKMANN Edelstahlrohr GmbH Rohrstrasse 1 A-2630 Ternitz, Austria Tel: 02630316/601 Fax: 02630316/894	Zert./cert: 121833 Seite/Page: 2 / 4 Datum/Date: 19.01.2007 e-mail: nicole.riegler@sber.co.at
--	--

Lieferung/Descr./Liste descr.:

Lieferschein Del.Note Avis d'exp. 80020661	Menge Quantity Poids 2.604,000 M	Gewicht Netweight Poids net 2.900,00 KG	Stk Pcs Pcs 434	Schmelze Heat Coulee 0QF079	Lot-Nr. Lot-No. Lot-No. 175742
---	---	--	--------------------------	--------------------------------------	---

17,15 X 3,2 MM / 3/8"NB X SCH 80S

Chemische Zusammensetzung/Chemical Composition/Composition chimique (%)

Schmelze Heat coulee 0QF079	MessNr No No 1	C 0,009	SI 0,34	MN 1,81	P 0,017	S 0,004	CR 18,26	MO 0,10	NI 10,29	CO 0,00
--------------------------------------	-------------------------	------------	------------	------------	------------	------------	-------------	------------	-------------	------------

B
0,0008

Mechanische Eigenschaften/Mechanical Properties/Charact. mecaniques

HÄRTE/HARDNESS/DURETE

Prüf-Nr/Test-No/No.Epr.: 175742

Probe Sample min	HRB
max	90
1	74
2	76

Ergebnis der Prüfungen/Test Result/Resultat des essais:

Die gestellten Anforderungen sind erfüllt.

The material has been furnished in accordance to the requirements.

Le material a été trouvé conforme aux exigences.

**SCHOELLER-BLECKMANN
 EDELSTAHLROHR GMBH**

Zeichen des Lieferwerks:

Brand of Manufacturer:

Marques de l'usine:



Zeichen des Prüfers:

Symbol of inspector:

Symbole de l'inspecteur:



Riegler

FR. N. RIEGLER
 (DER WERKSSACHVERSTÄNDIGE)
 (WORKS INSPECTOR/L'EXPERT DE USINE)



Zertifizierter Hersteller nach DGR 97/23/EG
 Certified Manufacturer to PED 97/23/EC
 von/by LRQA GmbH
 Kennnummer/Identification No.: 0525

ABNAHMEPRÜFZEUGNIS - INSPECTION CERTIFICATE
CERTIFICAT DE RECEPTION PAR L'USINE 3.1 C. C. P. U.
 nach / according to OENORM / DIN EN 10 204-3.1



SCHOELLER-BLECKMANN
 Edelstahlrohr GmbH
 Rohrstrasse 1
 A-2630 Ternitz, Austria
 Tel: 02630316/601
 Fax: 02630316/894

Zert./cert: 121833
 Seite/Page: 3 / 4
 Datum/Date: 19.01.2007
 e-mail: nicole.riegler@sber.co.at

ZUGVERSUCH/TENSION TEST/ESSAI DE TRACTION

Prüf-Nr/Test-No/No.Epr.: 175742

Probe Sample	TEMP °C	RP0.2 N/mm2	RP1.0 N/mm2	RM N/mm2	A5 %	A2" %
min	20	205	230	515	45	35
max	20			700		
1	20	266	301	613	57	61
2	20	270	304	615	56	59
3	20	266	302	615	57	60
4	20	274	311	616	55	59
5	20	264	299	612	57	61

Ergebnisse weiterer Prüfungen/Further test results/ Résultat d'autre essais
 INTERGR. CORR. TEST ACC. TO ASTM A262 PRACT.E: SATISFACTORY
 INTERGRANULAR CORROSION TEST ACCORDING TO
 DIN 50914/DIN EN ISO 3651-2 PRACT.A: SATISFACTORY
 INTERGR. CORR. TEST ACC. TO NFA 05-159: SATISFACTORY
 POSITIVE MATERIAL IDENTIFICATION TEST ON EACH TUBE/PIPE
 BY "X-RAY-FLUORESCENCE-ANALYZER": SATISFACTORY
 FLARING TEST: SATISFACTORY
 FLATTENING TEST: SATISFACTORY
 SOLUTION ANNEALED AT 1100 °C, 10 min,
 JET
 HYDROSTATIC TEST 172 BAR, 2500 PSI
 ON EACH TUBE: SATISFACTORY

THE TUBES/PIPES CONFORM ALSO TO NACE STANDARD MR0175-2003

BESICHTIGUNG UND NACHMESSUNG: IN ORDNUNG
 INSPECTION AND CHECKING OF DIMENSIONS: SATISFACTORY

KENNZEICHNUNG/MARKING: WERKSTOFF/MATERIAL-ABMESSUNG/DIMENSION

Ergebnis der Prüfungen/Test Result/Résultat des essais:
 Die gestellten Anforderungen sind erfüllt.
 The material has been furnished in accordance to the requirements.
 Le material a été trouvé conforme aux exigences.

**SCHOELLER-BLECKMANN
 EDELSTAHLROHR GMBH**

Zeichen des Lieferwerks:
 Brand of Manufacturer:
 Marques de l'usine:



Zeichen des Prüfers:
 Symbol of inspector:
 Symbole de l'inspecteur:



Riegler
 FR. N. RIEGLER
 (DER WERKSSACHVERSTÄNDIGE)
 (WORKS INSPECTOR/L'EXPERT DE USINE)



Zertifizierter Hersteller nach DGR 97/23/EG

Certified Manufacturer to PED 97/23/EC

von/by LRQA GmbH

Kennnummer/Identification No.: 0525

ABNAHMEPRÜFZEUGNIS - INSPECTION CERTIFICATE
CERTIFICAT DE RECEPTION PAR L'USINE 3.1 C. C. P. U.
nach / according to OENORM / DIN EN 10 204-3.1



SCHOELLER-BLECKMANN
Edelstahlrohr GmbH
Rohrstrasse 1
A-2630 Ternitz, Austria
Tel: 02630316/601
Fax: 02630316/894

Zert/cert: 121833

Seite/Page: 4 / 4

Datum/Date: 19.01.2007

e-mail: nicole.riegler@sber.co.at

SCHMELZE/HEAT NO.-PL NR./LOT NO.-SMLS/S-M-PKL.1

ERSCHMELZUNGSART/STEELMAKING PROCESS: EF+AOD

Ergebnis der Prüfungen/Test Result/Resultat des essais:

Die gestellten Anforderungen sind erfüllt.

The material has been furnished in accordance to the requirements.

Le material a été trouvé conforme aux exigences.

SCHOELLER-BLECKMANN
EDELSTAHLROHR GMBH

Zeichen des Lieferwerks:

Brand of Manufacturer:

Marques de l'usine:

SBS

Zeichen des Prüfers:

Symbol of inspector:

Symbole de l'inspecteur:



Riegler
FR. N. RIEGLER
(DER WERKSACHVERSTÄNDIGE)
(WORKS INSPECTOR/L'EXPERT DE USINE)

OFFICINE MECCANICHE SOLBIATE ARNO

Sede e Stabilimento: 21048 SOLBIATE ARNO (Varese) - Via Caronno Varese
 Tel. +39.0331.994.216 - Fax +39.0331.991.796
 web: http://www.omsafittings.it - e-mail: info@omsafittings.it
 Cap. Soc. € 25.823 - P. IVA IT 01217980129
 Mecc. VA 028482 - Registro Imprese di Busto Arsizio n. 12884 - R.E.A. Varese 163782



CHEMICAL ANALYSIS AND MECHANICAL TEST CERTIFICATE TO: DIN 50049 3.1.B - EN 10204/3.1B

Messrs. R.T.I. SRL 015 ARDENNE 2/8 20090 BORGHI MILLEPINI	ORDER : 7342/10 DATE : 06/10/2004 JOB : 04/91 /01920
---	--

Item	Q.TY	DESCRIPTION	MATERIAL	HEAT N°	STEEL MILL
3	3,00	TEE S.9000 3/4"11/2" SM F316L	SA-A182F316L	TCS	CLARSA
4	6,00	TEE S.9000 1/2" SM F316L	SA-A182F316L	472477	COBME ACCIAI
5	3,00	TEE S.9000 3/8" SM F316L	SA-A182F316L	834739	CLARSA
6	6,00	BONITO 90 S.9000 1/2" SM F316L	SA-A182F316L	463046	UBITECH
7	6,00	BONITO 90 S.9000 3/8" SM F316L	SA-A182F316L	58098	COBME ACCIAI

CHEMICAL ANALYSIS

Heat n°	C %	Mn %	Si %	P %	S %	Ni %	Cr %	Mo %	Ti %	Al %	V %	Cu %	Nb %	N %	%	%	C.E. %
TCS	0,020	1,630	0,410	0,028	0,029	10,050	16,850	2,030	0,000	0,000	0,000	0,000	0,000	0,024	0,000	0,000	0,000
472477	0,030	1,770	0,490	0,030	0,030	10,200	16,900	2,010	0,000	0,000	0,000	0,000	0,000	0,076	0,000	0,000	0,000
834739	0,030	1,670	0,440	0,028	0,028	10,000	16,700	2,010	0,000	0,000	0,000	0,000	0,000	0,025	0,000	0,000	0,000
463046	0,025	1,290	0,530	0,031	0,025	11,070	16,390	2,020	0,000	0,000	0,000	0,000	0,000	0,023	0,000	0,000	0,000
58098	0,029	1,750	0,430	0,030	0,022	10,030	16,500	2,010	0,000	0,000	0,000	0,390	0,000	0,080	0,000	0,000	0,000

MECHANICAL TEST

Heat n°	R N/mm²	S N/mm²	A %	C %	Bending Test	Flattening Test	Hydraulic Test	HARDNESS HB	IMPACT TEST J/cm²	HEAT TREATMENT
TCS	657,0	327,0	54,0	78,0				180 186		SOLUTION AT 1050
472477	601,0	327,0	58,0	76,0				178 179		SOLUTION AT 1050
834739	636,0	346,0	56,0	70,0				176 180		SOLUTION AT 1050
463046	548,0	282,0	59,0	75,0				161 162		SOLUTION AT 1050
58098	611,0	331,0	56,0	75,0				182 182		SOLUTION AT 1050

WE HEREBY CERTIFY THAT THE ABOVE IS IN ACCORDANCE WITH THE ORIGINAL CERTIFICATE WHICH IS HELD BY US.
 HARDNESS TEST FOR CARBON STEEL: HB 137 TO 187. FITTINGS MEET ANSI B16.11 & B2.1 REQUIREMENTS.
 FITTINGS ARE DIMENSIONAL AND SURFACE CHECKED WITHOUT OBJECTION. C/SAGGES AND PIPE NIPPLES SEAMLESS.
 UNION BOND JOINT, STEEL TO STEEL. TYPE OF SPECIMEN FOR ELONGATION: STANDARD ROUND.
 MATERIAL TO ASME Sec. II Part A Ed. 2004. ASTM & NACE MR0175 LATEST EDITION.

INSPECTION	Certificates issued by omsa S.r.l. are provided with this stamp in green colour.	CERTIFICATE N° 01540/00 DATE 19/10/2004 For Quality Control: E. TONERA
------------	---	--

Allegato 8:

Lista materiali certificati: Disegno 074-00-01rev3 tav. 8,
tratto orizzontale inferiore

Assieme

IMPIANTO PROVA BARRE

N°Riferimento Disegno

074.00.01

Rev.:

3

Tav. 8 rev .2

Data:

28/06/2010

Part. N°	Descrizione	Quantità	Lunghezza (mm)	Materiale	N° Certificato	Data Certificato	Fabbricante	N° di colata	Note
4	Flangia WN 2" ansi 2500 LF	1	-	ASTM A182 F304	53/10-1	29/04/'10	Steeltrade	379250	
4a	Flangia WN 2" ansi 2500 RJ	1	-	ASTM A182 F304	53/10-3	30/04/'10	Steeltrade	379250	
43c	Flangia WN 1" ansi 2500 LF	1	-	ASTM A182 F304	53/10-1	29/04/'10	Steeltrade	508471	
64/1	Curva 90° LR 2" sch. 160	1	-	ASTM WP 316	20100 128-2	28/01/'10	Lixue Group	TG080059	
64/2	Tee rid. 2"x 1/2" SW s. 6000	1	-	SA182 F304	00696/001	08/04/'10	OMSA	873477	
64/3	Curva 90° LR 1/2" sch. 80	2	-	ASTM WP 316	2010 0128-4	28/01/'10	Lixue Group	TG090121	
64/4	Tubo 1/2" sch.80	2	125	ASTM AISI 304	417490	19/12/'08	T.T.I. Tubacex	40405	
64/5	Tubo 2" sch.160	1	1367	ASTM AISI 304	428723	06/10/'09	T.T.I. Tubacex	41544	
64/6	Tubo 3/8" sch.80	1	2368	ASTM AISI 304	121833	19/01/'07	Schoeller-Bleckmann	40405	
64/7	Tee 3/8" SW s. 9000	1	-	SA182 F316	01540/001	19/10/'04	Olarra	834739	
64/8	Tubo 3/8" sch.80	1	725	ASTM AISI 304	121833	19/01/'07	Schoeller-Bleckmann	40405	
64/9	Riduzione concentrica (swage) 3/8" x 1" sch. 80	1	-	SA182 F304	00696/001	08/04/'10	OMSA	972190	

Compilato da:

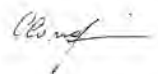

Data:

28/06/2010

CERTIFICATE OF CHEMICAL ANALYSIS AND MECHANICAL TEST.



STEELTRADE s.r.l.
 Loc. CATTAGNINA
 29010 ROTTOFRENO (PC) - ITALY
 TEL. +39 0523 780121
 FAX +39 0523 780123
 E-mail: inspection@steeltrade.it
 WEB: http://www.steeltrade.it

CERTIFICATE N. :53/10-1
 DATED :29/04/10

PURCHASER : SIET

YOUR ORDER : 74-10

JOB N. : ST 53/10

ITEM	Q.TY N°	DESCRIPTION	MATERIAL	HEAT CODE	HEAT
ITEM 01	4	WN FLANGE 1" LARGE MALE SCH.80 ANSI 2500	ASTM A182 F304	0B3	374150
ITEM 02	6	WN FLANGE 1" LARGE FEMALE SCH.80 ANSI 2500	ASTM A182 F304	B540	508471
ITEM 03	1	SLIP ON FLANGE 3" RF CL150	ASTM A182 F304	B248	259170
ITEM 04	1	SLIP ON FLANGE 2" RF CL150	ASTM A182 F304	B140	21728
ITEM 05	1	BLIND FLANGE 3" RF CL600 FORATA DIAM. 61 mm	ASTM A182 F304	B254	444625
ITEM 06	1	BLIND FLANGE 2" RF CL150 FORATA DIAM. 34 mm	ASTM A182 F304	B266	D82126A
ITEM 07	8	WN FLANGE 2" LARGE MALE SCH.160 ANSI 2500	ASTM A182 F304	B500	379250
ITEM 08	9	WN FLANGE 2" LARGE FEMALE SCH.160 ANSI 2500	ASTM A182 F304	B500	379250
ITEM 09	1	WN FLANGE 3/4" LARGE MALE SCH.160 ANSI 2500	ASTM A182 F304	B273	291450
ITEM 10	1	WN FLANGE 3/4" LARGE FEMALE SCH.160 ANSI 2500	ASTM A182 F304	B273	291450

Chemical Analysis

HEAT	C%	Mn%	Si%	P%	S%	Mo%	Cr%	Ni%	V%	Cu%	Ti%	Nb%	C.eq% *
374150	0.023	1.78	0.35	0.0028	0.0021		18.43	8.91					
508471	0.009	1.12	0.40	0.028	0.0026		18.14	9.12					
259170	0.014	1.75	0.31	0.026	0.024		18.33	8.14					
21728	0.017	0.77	0.32	0.028	0.002		18.25	9.20					
444625	0.013	1.10	0.41	0.026	0.026		18.20	9.22					
D82126A	0.019	1.61	0.42	0.025	0.025		18.26	10.17					
379250	0.022	1.71	0.24	0.03	0.021		18.22	8.93					
291450	0.022	1.76	0.31	0.029	0.026		18.32	8.20					

Mechanical Properties

HEAT	TENSILE TEST					IMPACT TEST					
	Tensile strength N/mm2	Yield point N/mm2	Elongation 2" %	Red. of Area %	Hardness HB	Type	Section	Temp.	Values J	Values J	Values J
374150	606	341	47.2	60.3							
508471	549	348	52.6	74.8							
259170	582	241	61.0	70.4							
21728	525	375	49.0	73.0							
444625	577	278	57.0	69.0							
D82126A	576	242	53.0	71.0							
379250	576	281	57.0	72.6							
291450	580	274	59.7	75.0							

NOTE:

- CERTIFICATE CONFORM TO : EN 10204.3.1
- STEEL MADE BY ELECTRIC FURNACE
- HEAT TREATMENT : SOLUTION ANNEALED
- ACCORDING TO PED 97/23/EC ANNEX 1 PAR.4.3
- PMI : NO OBJECTION (100% TESTED WITH NITON ANALYZER)
- DIMENSIONS : ASME B16.5
- VISUAL AND DIMENSIONAL TEST : SATISFACTORY

Quality Control
STEELTRADE



*C. eq. by long formula

The present certificate is in fully accordance with UNI CEI EN 45014-90

CERTIFICATE OF CHEMICAL ANALYSIS AND MECHANICAL TEST.



STEELTRADE s.r.l.
 Loc. CATTAGNINA
 29010 ROTTOFRENO (PC) - ITALY
 TEL. +39 0523 780121
 FAX +39 0523 780123
 E-mail: inspection@steeltrade.it
 WEB: http://www.steeltrade.it

CERTIFICATE N. : 53/10-3
 DATED : 30/04/10

PURCHASER : SIET

YOUR ORDER : 115-10

JOB N. : ST 53/10

ITEM	Q.TY N°	DESCRIPTION	MATERIAL	HEAT CODE	HEAT
1	2	WN FLANGE 2" RJ WT 8,74 mm SCH.160 CL.2500	ASTM A182 F304	B500	379250

Chemical Analysis

HEAT	C%	Mn%	Si%	P%	S%	Mo%	Cr%	Ni%	V%	Cu%	Ti%	Nb%	C.eq%*
379250	0.022	1.71	0.24	0.03	0.021		18.22	8.93					

Mechanical Properties

HEAT	TENSILE TEST					Hardness HB	IMPACT TEST						
	Tensile strenght N/mm2	Yield point N/mm2	Elongation 2" %	Red. of Area %	Type		Section	Temp.	Values J	Values J	Values J		
379250	576	281	57.0	72.6									

NOTE:

- CERTIFICATE CONFORM TO : EN 10204.3.1
- STEEL MADE BY ELECTRIC FURNACE
- HEAT TREATMENT : SOLUTION ANNEALED
- ACCORDING TO PED 97/23/EC ANNEX 1 PAR.4.3
- PMI : NO OBJECTION (100% TESTED WITH NITON ANALYZER)
- DIMENSIONS : ASME B16.5
- VISUAL AND DIMENSIONAL TEST : SATISFACTORY

Quality Control
STEELTRADE



*C. eq. by long formula

The present certificate is in fully accordance with UNI CEI EN 45014-90

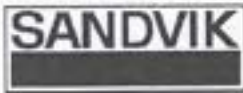

CertificateNo

128-2

1(2)

Date

2010-04-06

Riferimenti del cliente

Indirizzo del cliente

SIG.MARINELLI
R.T.I. SPA
VIA AMBROSOLI 2/A
20090 RODANO MILLEPINI MI
Italy

Codice prodotto Cliente

FBBLR-304L-2-160

Numero d'ordine

ORD.29527/10 29.3

Riferimenti di Sandvik

Codice prodotto Sandvik

FBBLR-304L-2-160

Lunghezza

Lotto

Colata

TG080059

Quantità consegnata

3 Pieces

Numero d'ordine del cliente

255501

Linea d'ordine del cliente

4

DDT Nr

15900



LIXUE GROUP CO.,LTD.

TINGTIAN INDUSTRIAL ZONE, RUIAN CITY, ZHEJIANG CHINA

MILL TEST CERTIFICATE ACCORDING TO EN 10204./3.1+PED 97/23/EC

ISO9001:2000

Client		Santrade Ltd				Certificate No		20100128-2			
Contract NO		GF20091217				Delivery Conditions		Solution Annealed, pickled and passivated			
Product		STAINLESS STEEL COLD FORMED BUTT WELD FITTINGS				Specification		ASTM/ASME A/SA 403-06 ANSI B16.9-07			
Item	Quantity	Size		Description		Grade	Heat No.	Heat treatment	Quenching		
2	300	1"	SCH10S	Long Radius Elbows 90°		WP304/304L-S	00910202	1052° 15 min.	RWQ		
10	20	2"	SCH160	Long Radius Elbows 90°		WP304/304L-S	TG080059	1052° 15 min.	RWQ		
14	100	3/4"	SCH80S	Long Radius Elbows 90°		WP304/304L-S	LH08-4022	1052° 15 min.	RWQ		
15	150	1/2"	SCH10S	Long Radius Elbows 90°		WP316/316L-S	TG080131	1052° 15 min.	RWQ		
17	100	1 1/4"	SCH10S	Long Radius Elbows 90°		WP316/316L-S	YT090227	1052° 15 min.	RWQ		
20	150	3"	SCH40S	Long Radius Elbows 90°		WP316/316L-S	TG090482	1052° 15 min.	RWQ		
23	20	4"	SCH160	Long Radius Elbows 90°		WP316/316L-S	TG090607	1052° 15 min.	RWQ		
chemical composition (%)											
Heat No.	C	Mn	P	S	Si	Cr	Ni	Mo	Ti		
00910202	0.030	1.86	0.033	0.002	0.280	18.30	8.19				
TG080059	0.027	0.82	0.039	0.002	0.540	18.11	8.07				
LH08-4022	0.016	0.85	0.034	0.009	0.52	18.39	8.15				
TG080131	0.025	0.77	0.039	0.001	0.430	18.58	11.06	2.08			
YT090227	0.022	0.78	0.038	0.003	0.380	16.67	10.08	2.08			
TG090482	0.024	0.86	0.040	0.003	0.390	16.70	10.06	2.07			
TG090607	0.021	0.85	0.039	0.002	0.440	16.76	10.09	2.08			
Mechanical Properties					NACE MR0175	IC Test ASTM A262E	Impact Test	Non-destructive Test	PMI	Visual	Dimensional
Heat No.	TS(Mpa)	YS (Mpa)	EL(%)	Hardness				PT			
00910202	534	255	62	HRB<=90	OK	OK	N/A	OK	OK	OK	OK
TG080059	560	245	60	HRB<=90	OK	OK	N/A	OK	OK	OK	OK
LH08-4022	615	305	50	HRB<=90	OK	OK	N/A	OK	OK	OK	OK
TG080131	575	265	60	HRB<=90	OK	OK	N/A	OK	OK	OK	OK
YT090227	535	225	62	HRB<=90	OK	OK	N/A	OK	OK	OK	OK
TG090482	575	255	60	HRB<=90	OK	OK	N/A	OK	OK	OK	OK
TG090607	560	260	57	HRB<=90	OK	OK	N/A	OK	OK	OK	OK
MARKINGS: LIXUE - SPEC - SIZE - SCH - GRADE - HEAT NO											
Materials have been manufactured in complete accordance with the purchasers order											
The melting process: Electric arc furnace											
PO NO: 24110											



Signed: 
 Date: 2010.01.28
 QUALITY ASSURANCE APPROVAL
 Q.A. Manager
 02. März 2010

SANOVIC ITALIA S.p.A.
REVIEWED

SANTRADE LTD LUCERNE

CHEMICAL ANALYSIS AND MECHANICAL TEST CERTIFICATE TO: DIN 50049 3.1 - EN 10204/3.1

Messrs. R.T.I. SPA VIA AMBROSOLI 2/A 20090 RODANO MILLEPINI MI	ORDER: 29525/10 DATE : 29/03/2010 JOB : 10/91 /00895
---	--



omsa S.R.L.

OFFICINE INGEGNERIE SOLBIATE ARNO

Sede e Stabilimento: 21048 SOLBIATE ARNO (Varese)
Via Caronno Varese
Tel. +39.0331.594.216 - Fax +39.0331.591.798
web: http://www.omsafinding.it - e-mail: info@omsafindings.it



ITEM	Q.TY	DESCRIPTION	MATERIAL	HEAT CODE	STEEL MLL	MLL CERT	HEAT N.
1	1,00	TEE S.6000 2*X3/4" SW F304L	SA182F304/304L	M416	COONE	2009005078	873477
2	2,00	TEE S.6000 2"x1/2" SW F304L	SA182F304/304L	M416	COONE	2009005078	873477
3	1,00	TEE S.6000 2*X1" SW F304L	SA182F304/304L	M416	COONE	2009005078	873477
4	2,00	GOMITO 90 S.3000 3/8" SW F304L	SA182F304/304L	D75	GLARRA	421.058	962852
5	1,00	SWAGE XS 1*X3/8" F8E F304L	SA182F304/304L	E87	COONE	2009037018	972199
6	1,00	MANICOTTO 1000 2" ISO7 RP F304L	SA182F304/304L	M463	ACC. VALBRUNA	HE8780643/2009	247199
7	1,00	MANICOTTO 1000 1.1/4" ISO7 RP F304L	SA182F304/304L	M476	ACC. VALBRUNA	802704/2009	423100

CHEMICAL ANALYSIS

HEAT CODE	C %	Mn %	Si %	P %	S %	Ni %	Cr %	Mo %	Ti %	Al %	V %	Cu %	Nb %	N %	C.E. %	NOTE
M416	0,020	1,290	0,330	0,032	0,030	8,060	18,120	0,430	0,000	0,000	0,000	0,330	0,000	0,077	0,000	0,000
M416	0,020	1,290	0,330	0,032	0,030	8,060	18,120	0,430	0,000	0,000	0,000	0,330	0,000	0,077	0,000	0,000
M416	0,020	1,290	0,330	0,032	0,030	8,060	18,120	0,430	0,000	0,000	0,000	0,330	0,000	0,077	0,000	0,000
D75	0,024	1,550	0,360	0,034	0,027	8,050	18,050	0,000	0,000	0,000	0,000	0,000	0,000	0,083	0,000	0,000
E87	0,024	1,350	0,370	0,032	0,027	8,060	18,080	0,390	0,000	0,000	0,000	0,300	0,000	0,092	0,000	0,000
M463	0,018	1,800	0,630	0,029	0,030	8,220	18,010	0,490	0,000	0,000	0,000	0,470	0,000	0,088	0,000	0,000
M476	0,016	1,770	0,590	0,026	0,025	8,170	18,270	0,430	0,000	0,000	0,000	0,500	0,000	0,088	0,000	0,000

MECHANICAL TEST

HEAT CODE	R N/mm ²	S N/mm ²	A %	C %	Bending Test	Flattenin g	Hydraulic Test	HARDNESS HB	IMPACT TEST J - °C	HEAT TREATMENT - °C	NOTE
M416	607,0	275,0	57,0	74,0				178 178		SOLUTION AT 1050	
M416	607,0	275,0	57,0	74,0				178 178		SOLUTION AT 1050	
M416	607,0	275,0	57,0	74,0				178 178		SOLUTION AT 1050	
D75	623,0	319,0	54,0	73,0				170 170		SOLUTION AT 1050	
E87	613,0	263,0	57,8	74,0				178 178	285 289 290 20	SOLUTION AT 1050	
M463	615,0	308,0	62,0	70,0				181 181		SOLUTION AT 1050	
M476	661,0	399,0	47,0	74,0				190 190	224 229 221 20	SOLUTION AT 1050	

WE HEREBY CERTIFY THAT THE ABOVE IS IN ACCORDANCE WITH THE ORIGINAL CERTIFICATE WHICH IS HELD BY US.
SPECIMEN FOR ELONGATION: STANDARD ROUND. FITTINGS MEET ANSI B16.11 & B31.99 REQUIREMENTS.UNIONS GROUND JOINT, STEEL TO STEEL
FITTINGS ARE DIMENSIONAL AND SURFACE CHECKED WITHOUT OBJECTION. C/SWADES AND PIPE NIPPLES SEAMLESS.
MATERIAL TO ASME Sec.II Part A Ed.2007 - ASTM 01.01 MACE MR01.75 MR01.03 LATEST EDITION. A105N NORMALISED AT 890 C.
IN ACCORDANCE WITH PED 97/23/EC ANNEX 1 SECT. 4.3, WHERE REQUIRED EDDY CURRENT OR HYDROSTATIC TEST WITHOUT OBJECTIONS.
ASTM A182 F11 NORM. AT 920 C. O'LET TO MSS SP97.

INSPECTION	O.M.S.A. S.R.L. Quality Assurance Manager (Davide Foschini) <i>Davide Foschini</i>	CERTIFICATE N° 00494/001	DATE 08/04/2010
------------	---	-----------------------------	--------------------

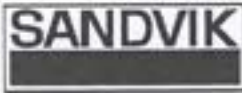

CertificateNo

128-4

1(2)

Date

2010-04-06

Riferimenti del cliente

Indirizzo del cliente

SIG.MARINELLI
R.T.I. SPA
VIA AMBROSOLI 2/A
20090 RODANO MILLEPINI MI
Italy

Codice prodotto Cliente

FBBLR-304L-1/2-80S

Numero d'ordine

ORD.29527/10 29.3

Riferimenti di Sandvik

Codice prodotto Sandvik

FBBLR-304L-1/2-80S

Lunghezza

Lotto

Colata

TG090121

Quantità consegnata

2 Pieces

Numero d'ordine del cliente

255501

Linea d'ordine del cliente

5

DDT Nr

15900



LIXUE GROUP CO.,LTD.

TINGTIAN INDUSTRIAL ZONE, RUIAN CITY, ZHEJIANG CHINA
MILL TEST CERTIFICATE ACCORDING TO EN 10204./3.1+PED 97/23/EC

ISO9001:2000

Client		Santrade Ltd			Certificate No		20100128-4					
Contract NO		GF20100106			Delivery Conditions		Solution Annealed ,pickled and passivated					
Product		STAINLESS STEEL COLD FORMED BUTT WELD FITTINGS			Specification		ASTM/ASME A/SA 403 -06 ANSI B16.9-07					
Item	Quantity	Size		Description	Grade	Heat No.	Heat treatment	Quenching				
1	200	1/2"	SCH10S	Long Radius Elbows 90°	WP304/304L-S	06V0013	1052° 15 min.	RWQ				
2	150	1/2"	SCH80S	Long Radius Elbows 90°	WP304/304L-S	TG090121	1052° 15 min.	RWQ				
5	100	1"	SCH80S	Long Radius Elbows 90°	WP304/304L-S	LH08-4022	1052° 15 min.	RWQ				
6	500	2"	SCH10S	Long Radius Elbows 90°	WP304/304L-S	SLA090320-7	1052° 15 min.	RWQ				
7	50	2"	SCH80S	Long Radius Elbows 90°	WP304/304L-S	SLA090320-7	1052° 15 min.	RWQ				
9	100	3"	SCH10S	Long Radius Elbows 90°	WP304/304L-S	TG090650	1052° 15 min.	RWQ				
chemical composition (%)												
Heat No.	C	Mn	P	S	Si	Cr	Ni	Mo	Ti			
06V0013	0.016	1.07	0.032	0.003	0.42	18.43	8.35					
TG090121	0.022	0.77	0.040	0.002	0.410	18.11	8.08					
LH08-4022	0.016	0.85	0.034	0.009	0.52	18.39	8.15					
SLA090320-7	0.022	1.04	0.033	0.002	0.410	18.19	8.07					
SLA090320-7	0.022	1.04	0.033	0.002	0.410	18.19	8.07					
TG090650	0.026	0.84	0.038	0.001	0.470	18.24	8.07					
Mechanical Properties					NACE MR0175	IC Test ASTM A282E	Impact Test	Non-destructive Test		PMI	Visual	Dimensional
Heat No.	TS(Mpa)	YS (Mpa)	EL(%)	Hardness				PT				
06V0013	570	275	60	HRB<90	OK	OK	N/A	OK	OK	OK	OK	
TG090121	575	255	62	HRB<90	OK	OK	N/A	OK	OK	OK	OK	
LH08-4022	625	255	55	HRB<90	OK	OK	N/A	OK	OK	OK	OK	
SLA090320-7	555	260	58	HRB<90	OK	OK	N/A	OK	OK	OK	OK	
SLA090320-7	565	255	60	HRB<90	OK	OK	N/A	OK	OK	OK	OK	
TG090650	577	288	60	HRB<90	OK	OK	N/A	OK	OK	OK	OK	
MARKINGS: LIXUE - SPEC - SIZE - SCH -GRADE- HEAT NO												
Materials have been manufactured in complete accordance with the purchasers order												
The melting process: Electric arc furnace												
PO NO: 24135												

Signed:
Date: 2010.01.28

Q.A.Manager



~~SANDVIK-ITALIA S.p.A.~~
REVIEWED

QUALITY ASSURANCE APPROVAL
02 März 2010
SANTRADE LTD LUCERNE



T.T.I. - Tubacex Tubos Inoxidables, S.A.

Registro Mercantil de Alava, Tomo 687, Folio 188, Hoja VI 2888 - N.I.F. A-41140227

Printed
19.01.

INSPECTION CERTIFICATE

EN 10204 3.1

Number: 417490
Page: 1 / 2

Rev: 6

Date: 19.12.2008

19.12.2008

CUSTOMER : PO : C02647 OUR REFERENCE: J9378
 STANDARD : DIN 17450 PK1/EN 10216-5 TC1 AD-2000 W2/W10/TRD100
 ADDIT. SPECS : NACE MR01.75-03 / ISO 15156
 GRADE : 1.4301/1.4306
 DIMENSIONS : 21,34 X 3,73
 MATERIAL : SEAMLESS STAINLESS STEEL TUBE
 COLD ROLLED; PASSIVATED;
 FLAIN ENDS SQUARE CUT;

---ITEM---	---HEAT---	NO. OF	---WEIGHT---	---TOTAL LENGTH---	---UNIT LENGTH---
YOUR	TTI.	PIECES	KG		
	3 40405	113	1152	686,90	5,5 - 6,5 MT

RAW MATERIAL

MELTING PROCESS: ELECTRIC FURNACE + A.O.D FROM: ACERALAVA
 PEELED BARS; MACROETCH TESTING: GOOD;

CHEMICAL COMPOSITION (*1 L: LADLE; C: PRODUCT)

*1 HEAT	C	Mn	Si	P	S	Ni	Cr	Cu	B	N
L 40405	0,012	1,49	0,290	0,032	0,0010	10,15	18,25	0,34	0,0009	0,0720



HEAT TREATMENT

SOLUTION ANNEALED 1100 °C HOLDING TIME >=1.5 MIN/MM WATER QUENCHED

= TESTS =		-----TENSION-----				--IMPACT TESTS--		HARDNESS			
NR.	TEST	T(°C)	MPA	R _m	R _p 0,2	R _p 1,0	A	Z	T(°C) MINIMUM	AVERAGE	HRB
40405	813809	20	603,0	303,0	345,0	58,8					85 86

TECHNOLOGICALS

FLATTENING TEST: GOOD
 FLARING TEST: GOOD
 RING EXPANDING TEST: GOOD

METALLURGICAL TEST

INTERGRANULAR CORROSION: A.262 PRACT. "E" / ISO 3651-2 : NOT OBJECTIONS

NON DESTRUCTIVE TEST

100 % HYDROSTATIC PRESSURE TESTED AT 80 BAR , DURING 6 SEC, GOOD
 STEEL GRADE CHECKING ON EACH TUBE BY SPECTROMETRY (PMI): SATISFACTORY
 DIMENSIONAL CHECKING ON EACH TUBE, SATISFACTORY
 VISUAL INSPECTION ON EACH TUBE, SATISFACTORY

OTHER MATERIAL SPECIFICATIONS

A-SA312M-06 ED.07/NF A49117-85 TP304-304L/Z2-Z6 CN 18.10-09

MARKS

TX2
 TUBACEX 21,34 X 3,73 1.4301-1.4306 H S 1 - EN 10216-5 TC1 1.4301-
 1.4306 CFD - NF A49-117 Z2-Z6 CN 18.10-09 - A-SA 312 TP304-304L SMUS
 HEAT/..... PMI TX2 SPAIN

REMARKS

TOL.ISO T32 D3/T3
 MATERIAL MANUFACTURER APPROVED WITH CERTIFICATE NR. 07/2001/MUC BY TÜV SÜDDEUTSCHLAND
 (NOTIFIED BODY 0036) TO ISSUE CERTIFICATES OF SPECIFIC PRODUCT CONTROL IN
 ACCORDANCE WITH PRESSURE EQUIPMENT DIRECTIVE 97/23/EC ANNEX 1 POINT 4.3.
 AS PER LETTER DATED 21.08.92 TÜV SÜDWEST DECLINES COUNTERSIGNING
 MATERIAL CHARACTERISTICS COMPLY WITH POINT 7.5 OF ANNEX I TO PED BY HAVING AN ELONGATION
 AFTER RUPTURE AT TENSILE TEST NO LESS THAN 14 % AND A BENDING RUPTURE ENERGY AT IMPACT TE



We hereby certify that the material herein described has been manufactured, sampled, tested and inspected in accordance with above standards and specifications and satisfies the order's requirements.
 This certificate is issued by a computerized system and it is valid without original signature.
 In case the owner of the certificate would release a copy of it, he must accept its conformity to the issued, assuming the responsibility for any misuse of T.T.I., S.A. not allowed use.
 Any forgery or falsification of this certificate shall legally prosecuted.

T.T.I.
 Tubacex Tubos Inoxidables, S.A.

INGENIERIA DE CALIDAD



Juan Alana Zubizar



TUBACEX

T.T.I. - Tubacex Tubos Inoxidables, S.A.

Registro Mercantil de Aleva, Tomo 587, Folio 189, Hoja VI 2005 - N.I.F. A-01148227

Printed on:
19.01.2009

INSPECTION CERTIFICATE

EN 10204 3.1

Number: 417490
Page: 2 / 2

Rev: 0

Date: 19.12.2008

19.12.2008

CUSTOMER : PO : **C02647** OUR REFERENCE: **J9378**
 STANDARD : **DIN 17458 PK1/EN 10216-5 TC1 AD-2000 W2/W10/TRD100**
 ADDIT. SPECS : **NACE MR01.75-03 / ISO 15156**
 GRADE : **1.4301/1.4306**
 DIMENSIONS : **21,34 X 3,73**
 MATERIAL : **SEAMLESS STAINLESS STEEL TUBE**
COLD ROLLED; PASSIVATED;
PLAIN ENDS SQUARE CUT;

ST NO LESS THAN 27 J AT 20°C.

CONFORME ALL'ORIGINALE
RUBIVAL INOX S.R.L.



We hereby certify that the material herein described has been manufactured, sampled, tested and inspected in accordance with above standards and specifications and satisfies the order's requirements.
The certificate is issued by a computerized system and it is valid without original signature.
In case the owner of the certificate would release a copy of it, he must attend its conformity to the issued, assuming the responsibility for any error or T.T.I. S.A. not identical use.
Any forgery or falsification of this certificate shall legally prosecuted.

T.T.I.
Tubacex Tubos Inoxidables, S.A.

INGENIERIA DE CALIDAD

[Signature]
Joni Alzola Zubizarreta



T.T.I. - Tubacex Tubos Inoxidables, S.A.

Registro Mercantil de Alava, Tomo 587, Folio 198, Hoja VI 2886 - N.I.F. A-01140227

Printed on:
21.10.2009

INSPECTION CERTIFICATE

EN 10204 3.1

Number: 428723

Page: 1 / 2

Rev: 0

Date: 06.10.2009

06.10.2009

CUSTOMER : PO : **C02989*** OUR REFERENCE: **K0002**
 STANDARD : **EN 10216-5 TC2**
 ADDIT. SPECS : **NACE MR01.75-03 / NACE MR03-03 / ISO 15156-3**
 GRADE : **1.4301/1.4306**
 DIMENSIONS : **60,32 X 8,74**
 MATERIAL : **SEAMLESS STAINLESS STEEL TUBE**
COLD ROLLED; PICKLED-PASSIVATED;
PLAIN BEVELLED ENDS;

ITEM	HEAT	NO. OF	WEIGHT	TOTAL LENGTH	UNIT LENGTH	
YOUR	TTI.	PIECES	KG			
	66	41544	28	1933	172,52	5,5 - 6,5 MT

RAW MATERIAL

MELTING PROCESS: ELECTRIC FURNACE + A.O.D FROM: ACERALAVA
 PEELED BARS; MACROETCH TESTING: GOOD;

CHEMICAL COMPOSITION (*1 L: LADLE; C: PRODUCT)

*1 HEAT	C	Mn	Si	P	S	Ni	Cr	N
L 41544	0,017	1,50	0,300	0,027	0,0010	10,15	18,30	0,0720

HEAT TREATMENT

SOLUTION ANNEALED 1100 °C HOLDING TIME >=1.5 MIN/MM WATER QUENCHED

TESTS		TENSION				IMPACT TESTS		HARDNESS	
NR.	NR.	T(°C)	MPA	RP 0,2	RP 1,0	A	Z	T(°C) MINIMUM AVERAGE	HRB
HEAT	TEST								
41544	908135	20	550,0	321,0	369,0	46,7			81 82
41544	908135A	20	550,0	322,0	369,0	45,3			81 82

TECHNOLOGICALS

FLATTENING TEST: GOOD
 RING EXPANDING TEST: GOOD

METALLURGICAL TEST

INTERGRANULAR CORROSION: A262 "E"/ISO 3651-2/ 5 TEST ACC.MIL-P-1144D+24691/3: GOOD

NON DESTRUCTIVE TEST

100 % U.T TO EN10246-7 (ENT.5%, MIN.0,3MM) , GOOD
 100 % EDDY CURRENT TEST AT E-426 , GOOD
 100 % HYDROSTATIC PRESSURE TESTED AT 80 BAR , DURING 5 SEC, GOOD
 STEEL GRADE CHECKING ON EACH TUBE BY SPECTROMETRY (PMI): SATISFACTORY
 DIMENSIONAL CHECKING ON EACH TUBE, SATISFACTORY
 VISUAL INSPECTION ON EACH TUBE, SATISFACTORY



OTHER MATERIAL SPECIFICATIONS

A/SA312M-08A ED.07 + 08 ADD TP304-304L
 A/SA376M-06 ED.07 + 08 ADD TP304

MARKS

TX2
 TUBACEX 60,32 X 8,74 EN 10216-5 TC2 1.4301-1.4306 CFD ASTM-ASME
 A-SA 312 TP304-304L A-SA 376 TP304 SMLS HEAT/..... PMI TX2
 SPAIN

REMARKS

TOL. ISO 1127 D3-T3 / ASTM A999
 NO WELD REPAIR WAS PERFORMED

COPIA CONFORME ALL'ORIGINALE



We hereby certify that the material herein described has been manufactured, sampled, tested and inspected in accordance with above standards and specifications and satisfies the order's requirements.
 This certificate is issued by a computerized system and it is valid without original signature. In case the owner of this certificate would request a copy of it, he must advise its conformity to the issuer, assuming the responsibility for any unlawful or T.T.I.,S.A. not allowed use.
 Any forgery or falsification of this certificate shall legally prosecuted.

T.T.I.
 Tubacex Tubos Inoxidables, S.A.

INGENIERIA DE CALIDAD

[Signature]
 JON ARBIDE ZUBEROA



T.T.I. - Tubacex Tubos Inoxidables, S.A.

Registro Mercantil de Álava, Tomo 587, Folio 188, Hoja VI 2886 - N.I.F. A-61140227

Printed on:
21.10.2009

INSPECTION CERTIFICATE

EN 10204 3.1

Number: 428723
Page: 2 / 2

Rev: 0

Date: 06.10.2009 06.10.2009

CUSTOMER : PO : **C02989*** OUR REFERENCE: **K0002**

STANDARD : **EN 10216-5 TC2**

ADDIT. SPECS : **NACE MR01.75-03 / NACE MR03-03 / ISO 15156-3**

GRADE : **1.4301/1.4306**

DIMENSIONS : **60,32 X 8,74**

MATERIAL : **SEAMLESS STAINLESS STEEL TUBE**
COLD ROLLED; PICKLED-PASSIVATED;
PLAIN BEVELLED ENDS;

MATERIAL MANUFACTURER APPROVED WITH CERTIFICATE NR. 07/2001/MUC BY TÜV SÜDDEUTSCHLAND (NOTIFIED BODY 0036) TO ISSUE CERTIFICATES OF SPECIFIC PRODUCT CONTROL IN ACCORDANCE WITH PRESSURE EQUIPMENT DIRECTIVE 97/23/EC ANNEX 1 POINT 4.3. MATERIAL CHARACTERISTICS COMPLY WITH POINT 7.5 OF ANNEX I TO PED BY HAVING AN ELONGATION AFTER RUPTURE AT TENSILE TEST NO LESS THAN 14 % AND A BENDING RUPTURE ENERGY AT IMPACT TEST NO LESS THAN 27 J AT 20°C.



We hereby certify that the material herein described has been manufactured, sampled, tested and inspected in accordance with above standards and specifications and satisfies the order's requirements.

This certificate is issued by a computerized system and it is valid without original signature. In case the owner of the certificate would release a copy of it, he must state its conformity to the issued, assuming the responsibility for any unlawful or T.T.I., S.A. not allowed use.

Any forgery or falsification of this certificate shall legally prosecuted.

T.T.I. Tubacex Tubos Inoxidables, S.A.

INGENIERIA DE CALIDAD

[Signature]
Jon Albano Zubizarreta

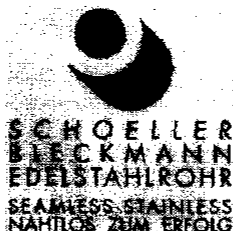

Zertifizierter Hersteller nach DGR 97/23/EG
Certified Manufacturer to PED 97/23/EC
von/by LRQA GmbH
Kennnummer/Identification No.: 0525

ABNAHMEPRÜFZEUGNIS - INSPECTION CERTIFICATE
CERTIFICAT DE RECEPTION PAR L'USINE 3.1 C. C. P. U.
nach / according to OENORM / DIN EN 10 204-3.1



SCHOELLER-BLECKMANN
Edelstahlrohr GmbH
Rohrstrasse 1
A-2630 Ternitz, Austria
Tel: 02630316/601
Fax: 02630316/894

Zert./cert: 121833

Seite/Page: 1 / 4

Datum/Date: 19.01.2007

e-mail: nicole.riegler@sber.co.at

Besteller/Purchaser/Committant

Bestell-Nr./Purchaser's Order No/ No. de commande: 1563

Auftrags-Nr./Works Order No/No. de commande d'usine: 454264 Pos. 30

Erzeugnis/Product/Produit.:

SEAML. STAINL. STEEL TUBES/PIPES,
SBS GRADE A600, 1.4301/1.4306, TP304/TP304L,
FINISH M = COLD FINISHED, BRIGHT ANNEALED,
TECHN. COND. ACC.
ASTM A312/A312M-04B, NACE MR0175/ISO 15156-3:2003,
ASME SECT.II PART.A SA312/SA312M-2004 ED. 2005 ADD,
DIN 17458/07.85 PKL.1, NFA 49-117 SEPT.1985,
EN 10216-5:2004 TEST CATEGORY 1,
CORROSION TESTED TO ASTM A262 PRACTICE E,
DIN 50914/ISO 3651-2 PRACT.A AND NFA 05-159,
TOLERANCES ACC.
ASTM A999/A999M-04A,
ASME SECT.II PART.A SA530/SA530M-2004 ED. 2005 ADD,
FIXED LENGTHS 6.000 MM - 6.000 MM, + 3,0 MM,
PLAIN ENDS,



Ergebnis der Prüfungen/Test Result/Resultat des essais:

Die gestellten Anforderungen sind erfüllt.

The material has been furnished in accordance to the requirements.

Le material a été trouvé conforme aux exigences.

**SCHOELLER-BLECKMANN
EDELSTAHLROHR GMBH**

Zeichen des Lieferwerks:

Brand of Manufacturer:

Marques de l'usine:

SBS

Zeichen des Prüfers:

Symbol of inspector:

Symbole de l'inspecteur:



Riegler
FR. N. RIEGLER
(DER WERKSACHVERSTÄNDIGE)
(WORKS INSPECTOR/L'EXPERT DE USINE)

COPIA CONFORME ALL'ORIGINALE
RUBIVAL INOX S.R.L.



Zertifizierter Hersteller nach DGR 97/23/EG
 Certified Manufacturer to PED 97/23/EC
 von/by LRQA GmbH
 Kennnummer/Identification No.: 0525

**ABNAHMEPRÜFZEUGNIS - INSPECTION CERTIFICATE
 CERTIFICAT DE RECEPTION PAR L'USINE 3.1 C. C. P. U.
 nach / according to OENORM / DIN EN 10 204-3.1**



SCHOELLER-BLECKMANN Edelstahlrohr GmbH Rohrstrasse 1 A-2630 Ternitz, Austria Tel: 02630316/601 Fax: 02630316/894	Zert./cert: 121833 Seite/Page: 2 / 4 Datum/Date: 19.01.2007 e-mail: nicole.riegler@sber.co.at
--	--

Lieferung/Descr./Liste descr.:

Lieferschein Del.Note Avis d'exp. 80020661	Menge Quantity Poids 2.604,000 M	Gewicht Netweight Poids net 2.900,00 KG	Stk Pcs Pcs 434	Schmelze Heat Coulee 0QF079	Lot-Nr. Lot-No. Lot-No. 175742
---	---	--	--------------------------	--------------------------------------	---

17,15 X 3,2 MM / 3/8"NB X SCH 80S

Chemische Zusammensetzung/Chemical Composition/Composition chimique (%)

Schmelze Heat coulee 0QF079	MessNr No No 1	C 0,009	SI 0,34	MN 1,81	P 0,017	S 0,004	CR 18,26	MO 0,10	NI 10,29	CO 0,00
--------------------------------------	-------------------------	------------	------------	------------	------------	------------	-------------	------------	-------------	------------

B
0,0008

Mechanische Eigenschaften/Mechanical Properties/Charact. mecaniques

HÄRTE/HARDNESS/DURETE

Prüf-Nr/Test-No/No.Epr.: 175742

Probe Sample min	HRB
max	90
1	74
2	76

Ergebnis der Prüfungen/Test Result/Resultat des essais:

Die gestellten Anforderungen sind erfüllt.

The material has been furnished in accordance to the requirements.

Le material a été trouvé conforme aux exigences.

**SCHOELLER-BLECKMANN
EDELSTAHLROHR GMBH**

Zeichen des Lieferwerks:

Brand of Manufacturer:

Marques de l'usine:



Zeichen des Prüfers:

Symbol of inspector:

Symbole de l'inspecteur:



Riegler

FR. N. RIEGLER
(DER WERKSSACHVERSTÄNDIGE)
(WORKS INSPECTOR/L'EXPERT DE USINE)



Zertifizierter Hersteller nach DGR 97/23/EG
 Certified Manufacturer to PED 97/23/EC
 von/by LRQA GmbH
 Kennnummer/Identification No.: 0525

ABNAHMEPRÜFZEUGNIS - INSPECTION CERTIFICATE
CERTIFICAT DE RECEPTION PAR L'USINE 3.1 C. C. P. U.
 nach / according to OENORM / DIN EN 10 204-3.1



SCHOELLER-BLECKMANN
 Edelstahlrohr GmbH
 Rohrstrasse 1
 A-2630 Ternitz, Austria
 Tel: 02630316/601
 Fax: 02630316/894

Zert./cert: 121833
 Seite/Page: 3 / 4
 Datum/Date: 19.01.2007
 e-mail: nicole.riegler@sber.co.at

ZUGVERSUCH/TENSION TEST/ESSAI DE TRACTION

Prüf-Nr/Test-No/No.Epr.: 175742

Probe Sample	TEMP °C	RP0.2 N/mm2	RP1.0 N/mm2	RM N/mm2	A5 %	A2" %
min	20	205	230	515	45	35
max	20			700		
1	20	266	301	613	57	61
2	20	270	304	615	56	59
3	20	266	302	615	57	60
4	20	274	311	616	55	59
5	20	264	299	612	57	61

Ergebnisse weiterer Prüfungen/Further test results/ Résultat d'autre essais
 INTERGR. CORR. TEST ACC. TO ASTM A262 PRACT.E: SATISFACTORY
 INTERGRANULAR CORROSION TEST ACCORDING TO
 DIN 50914/DIN EN ISO 3651-2 PRACT.A: SATISFACTORY
 INTERGR. CORR. TEST ACC. TO NFA 05-159: SATISFACTORY
 POSITIVE MATERIAL IDENTIFICATION TEST ON EACH TUBE/PIPE
 BY "X-RAY-FLUORESCENCE-ANALYZER": SATISFACTORY
 FLARING TEST: SATISFACTORY
 FLATTENING TEST: SATISFACTORY
 SOLUTION ANNEALED AT 1100 °C, 10 min,
 JET
 HYDROSTATIC TEST 172 BAR, 2500 PSI
 ON EACH TUBE: SATISFACTORY

THE TUBES/PIPES CONFORM ALSO TO NACE STANDARD MR0175-2003

BESICHTIGUNG UND NACHMESSUNG: IN ORDNUNG
 INSPECTION AND CHECKING OF DIMENSIONS: SATISFACTORY

KENNZEICHNUNG/MARKING: WERKSTOFF/MATERIAL-ABMESSUNG/DIMENSION

Ergebnis der Prüfungen/Test Result/Resultat des essais:
 Die gestellten Anforderungen sind erfüllt.
 The material has been furnished in accordance to the requirements.
 Le material a été trouvé conforme aux exigences.

**SCHOELLER-BLECKMANN
 EDELSTAHLROHR GMBH**

Zeichen des Lieferwerks:
 Brand of Manufacturer:
 Marques de l'usine:



Zeichen des Prüfers:
 Symbol of inspector:
 Symbole de l'inspecteur:



Riegler
 FR. N. RIEGLER
 (DER WERKSSACHVERSTÄNDIGE)
 (WORKS INSPECTOR/L'EXPERT DE USINE)

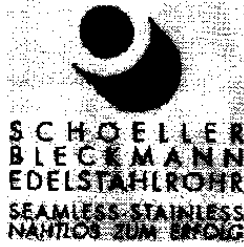

Zertifizierter Hersteller nach DGR 97/23/EG
Certified Manufacturer to PED 97/23/EC
von/by LRQA GmbH
Kennnummer/Identification No.: 0525

ABNAHMEPRÜFZEUGNIS - INSPECTION CERTIFICATE
CERTIFICAT DE RECEPTION PAR L'USINE 3.1 C. C. P. U.
nach / according to OENORM / DIN EN 10 204-3.1



SCHOELLER-BLECKMANN
Edelstahlrohr GmbH
Rohrstrasse 1
A-2630 Ternitz, Austria
Tel: 02630316/601
Fax: 02630316/894

Zert/cert: 121833
Seite/Page: 4 / 4
Datum/Date: 19.01.2007
e-mail: nicole.riegler@sber.co.at

SCHMELZE/HEAT NO.-PL NR./LOT NO.-SMLS/S-M-PKL.1

ERSCHMELZUNGSART/STEELMAKING PROCESS: EF+AOD

Ergebnis der Prüfungen/Test Result/Resultat des essais:
Die gestellten Anforderungen sind erfüllt.
The material has been furnished in accordance to the requirements.
Le material a été trouvé conforme aux exigences.

SCHOELLER-BLECKMANN
EDELSTAHLROHR GMBH

Zeichen des Lieferwerks:
Brand of Manufacturer:
Marques de l'usine:

SBS

Zeichen des Prüfers:
Symbol of inspector:
Symbole de l'inspecteur:



Riegler
FR. N. RIEGLER
(DER WERKSACHVERSTÄNDIGE)
(WORKS INSPECTOR/L'EXPERT DE USINE)

OFFICINE MECCANICHE SOLBIATE ARNO

Sede e Stabilimento: 21048 SOLBIATE ARNO (Varese) - Via Caronno Varese
 Tel. +39.0331.994.216 - Fax +39.0331.991.796
 web: http://www.omsafittings.it - e-mail: info@omsafittings.it
 Cap. Soc. € 25.823 - P. IVA IT 01217980129
 Mecc. VA 028482 - Registro Imprese di Busto Arsizio n. 12884 - R.E.A. Varese 163782



CHEMICAL ANALYSIS AND MECHANICAL TEST CERTIFICATE TO: DIN 50049 3.1.B - EN 10204/3.1B

Messrs. R.T.I. SRL 015 ARDENNE 2/0 20090 BORGHI MILLEPINI	ORDER : 7342/10 DATE : 06/10/2004 JOB : 04/91 /01920
---	--

Item	Q.TY	DESCRIPTION	MATERIAL	HEAT N°	STEEL MILL
3	3,00	TEE S.9000 3/4"11/2" SM F316L	SA-A182F316L	TCS	CLARSA
4	6,00	TEE S.9000 1/2" SM F316L	SA-A182F316L	472477	COBME ACCIAI
5	3,00	TEE S.9000 3/8" SM F316L	SA-A182F316L	834739	CLARSA
6	6,00	BONITO 90 S.9000 1/2" SM F316L	SA-A182F316L	463046	UBITECH
7	6,00	BONITO 90 S.9000 3/8" SM F316L	SA-A182F316L	58098	COBME ACCIAI

CHEMICAL ANALYSIS

Heat n°	C %	Mn %	Si %	P %	S %	Ni %	Cr %	Mo %	Ti %	Al %	V %	Cu %	Nb %	N %	%	%	C.E. %
TCS	0,020	1,630	0,410	0,028	0,029	10,050	16,850	2,030	0,000	0,000	0,000	0,000	0,000	0,024	0,000	0,000	0,000
472477	0,030	1,770	0,490	0,030	0,030	10,200	16,900	2,010	0,000	0,000	0,000	0,000	0,000	0,076	0,000	0,000	0,000
834739	0,030	1,670	0,440	0,028	0,028	10,000	16,700	2,010	0,000	0,000	0,000	0,000	0,000	0,025	0,000	0,000	0,000
463046	0,025	1,290	0,530	0,031	0,025	11,070	16,390	2,020	0,000	0,000	0,000	0,000	0,000	0,023	0,000	0,000	0,000
58098	0,029	1,750	0,430	0,030	0,022	10,030	16,500	2,010	0,000	0,000	0,000	0,390	0,000	0,080	0,000	0,000	0,000

MECHANICAL TEST

Heat n°	R N/mm²	S N/mm²	A %	C %	Bending Test	Flattening Test	Hydraulic Test	HARDNESS HB	IMPACT TEST J/cm²	HEAT TREATMENT
TCS	657,0	327,0	54,0	78,0				180 186		SOLUTION AT 1050
472477	601,0	327,0	58,0	76,0				178 179		SOLUTION AT 1050
834739	636,0	346,0	56,0	70,0				176 180		SOLUTION AT 1050
463046	548,0	282,0	59,0	75,0				161 162		SOLUTION AT 1050
58098	611,0	331,0	56,0	75,0				182 182		SOLUTION AT 1050

WE HEREBY CERTIFY THAT THE ABOVE IS IN ACCORDANCE WITH THE ORIGINAL CERTIFICATE WHICH IS HELD BY US.
 HARDNESS TEST FOR CARBON STEEL: HB 137 TO 187. FITTINGS MEET ANSI B16.11 & B2.1 REQUIREMENTS.
 FITTINGS ARE DIMENSIONAL AND SURFACE CHECKED WITHOUT OBJECTION. C/SWAGES AND PIPE NIPPLES SEAMLESS.
 UNION BOND JOINT, STEEL TO STEEL. TYPE OF SPECIMEN FOR ELONGATION: STANDARD ROUND.
 MATERIAL TO ASME Sec. II Part A Ed. 2004. ASTM & NACE MR0175 LATEST EDITION.

INSPECTION	Certificates issued by omsa S.r.l. are provided with this stamp in green colour.	CERTIFICATE N° 01540/00 DATE 19/10/2004 For Quality Control: E. TONERA
------------	---	--

Allegato 9:

Lista materiali certificati: Disegno 074-00-01rev3 tav. 9, EBT

Assieme

IMPIANTO PROVA BARRE

N°Riferimento Disegno

074.00.01

Rev.:

3

Tav. 9 rev .2

Data:

28/06/2010

Part. N°	Descrizione	Quantità	Lunghezza (mm)	Materiale	N°Certificato	Data Certificato	Fabbricante	N°di colata	Note
43c	Flangia WN 1" ansi 2500 LM	1	-	ASTM A182 F304	53/10-1	29/04/'10	Steeltrade	374150	
43b	Flangia WN 1" ansi 2500 LF	1	-	ASTM A182 F304	53/10-1	29/04/'10	Steeltrade	508471	
67	Tubo 1" sch.80	1	3657	ASTM AISI 304	425772	06/10/'09	T.T.I. Tubacex	41659	

Compilato da:



Data:

28/06/2010

CERTIFICATE OF CHEMICAL ANALYSIS AND MECHANICAL TEST.



STEELTRADE s.r.l.
 Loc. CATTAGNINA
 29010 ROTTOFRENO (PC) - ITALY
 TEL. +39 0523 780121
 FAX +39 0523 780123
 E-mail: inspection@steeltrade.it
 WEB: http://www.steeltrade.it

CERTIFICATE N. :53/10-1
 DATED :29/04/10

PURCHASER : SIET

YOUR ORDER : 74-10

JOB N. : ST 53/10

ITEM	Q.TY N°	DESCRIPTION	MATERIAL	HEAT CODE	HEAT
ITEM 01	4	WN FLANGE 1" LARGE MALE SCH.80 ANSI 2500	ASTM A182 F304	0B3	374150
ITEM 02	6	WN FLANGE 1" LARGE FEMALE SCH.80 ANSI 2500	ASTM A182 F304	B540	508471
ITEM 03	1	SLIP ON FLANGE 3" RF CL150	ASTM A182 F304	B248	259170
ITEM 04	1	SLIP ON FLANGE 2" RF CL150	ASTM A182 F304	B140	21728
ITEM 05	1	BLIND FLANGE 3" RF CL600 FORATA DIAM. 61 mm	ASTM A182 F304	B254	444625
ITEM 06	1	BLIND FLANGE 2" RF CL150 FORATA DIAM. 34 mm	ASTM A182 F304	B266	D82126A
ITEM 07	8	WN FLANGE 2" LARGE MALE SCH.160 ANSI 2500	ASTM A182 F304	B500	379250
ITEM 08	9	WN FLANGE 2" LARGE FEMALE SCH.160 ANSI 2500	ASTM A182 F304	B500	379250
ITEM 09	1	WN FLANGE 3/4" LARGE MALE SCH.160 ANSI 2500	ASTM A182 F304	B273	291450
ITEM 10	1	WN FLANGE 3/4" LARGE FEMALE SCH.160 ANSI 2500	ASTM A182 F304	B273	291450

Chemical Analysis

HEAT	C%	Mn%	Si%	P%	S%	Mo%	Cr%	Ni%	V%	Cu%	Ti%	Nb%	C.eq% *
374150	0.023	1.78	0.35	0.0028	0.0021		18.43	8.91					
508471	0.009	1.12	0.40	0.028	0.0026		18.14	9.12					
259170	0.014	1.75	0.31	0.026	0.024		18.33	8.14					
21728	0.017	0.77	0.32	0.028	0.002		18.25	9.20					
444625	0.013	1.10	0.41	0.026	0.026		18.20	9.22					
D82126A	0.019	1.61	0.42	0.025	0.025		18.26	10.17					
379250	0.022	1.71	0.24	0.03	0.021		18.22	8.93					
291450	0.022	1.76	0.31	0.029	0.026		18.32	8.20					

Mechanical Properties

HEAT	TENSILE TEST					IMPACT TEST					
	Tensile strength N/mm2	Yield point N/mm2	Elongation 2" %	Red. of Area %	Hardness HB	Type	Section	Temp.	Values J	Values J	Values J
374150	606	341	47.2	60.3							
508471	549	348	52.6	74.8							
259170	582	241	61.0	70.4							
21728	525	375	49.0	73.0							
444625	577	278	57.0	69.0							
D82126A	576	242	53.0	71.0							
379250	576	281	57.0	72.6							
291450	580	274	59.7	75.0							

NOTE:

- CERTIFICATE CONFORM TO : EN 10204.3.1
- STEEL MADE BY ELECTRIC FURNACE
- HEAT TREATMENT : SOLUTION ANNEALED
- ACCORDING TO PED 97/23/EC ANNEX 1 PAR.4.3
- PMI : NO OBJECTION (100% TESTED WITH NITON ANALYZER)
- DIMENSIONS : ASME B16.5
- VISUAL AND DIMENSIONAL TEST : SATISFACTORY

Quality Control
STEELTRADE



*C. eq. by long formula

The present certificate is in fully accordance with UNI CEI EN 45014-90



T.T.I. - Tubacex Tubos Inoxidables, S.A.

Registro Mercantil de Alava, Tomo 587, Folio 188, Hoja VI 2888 - N.I.F. A-41140227

Printed
19.01.

INSPECTION CERTIFICATE

EN 10204 3.1

Number: 417490
Page: 1 / 2

Rev: 6

Date: 19.12.2008

19.12.2008

CUSTOMER : PO : C02647 OUR REFERENCE: J9378
 STANDARD : DIN 17450 PK1/EN 10216-5 TC1 AD-2000 W2/W10/TRD100
 ADDIT. SPECS : NACE MR01.75-03 / ISO 15156
 GRADE : 1.4301/1.4306
 DIMENSIONS : 21,34 X 3,73
 MATERIAL : SEAMLESS STAINLESS STEEL TUBE
 COLD ROLLED; PASSIVATED;
 FLAIN ENDS SQUARE CUT;

---ITEM---	---HEAT---	NO. OF	---WEIGHT---	---TOTAL LENGTH---	---UNIT LENGTH---
YOUR	TTI.	PIECES	KG		
	3 40405	113	1152	686,90	5,5 - 6,5 MT

RAW MATERIAL

MELTING PROCESS: ELECTRIC FURNACE + A.O.D FROM: ACERALAVA
 PEELED BARS; MACROETCH TESTING: GOOD;

CHEMICAL COMPOSITION (*1 L: LADLE; C: PRODUCT)

*1 HEAT	C	Mn	Si	P	S	Ni	Cr	Cu	B	N
L 40405	0,012	1,49	0,290	0,032	0,0010	10,15	18,25	0,34	0,0009	0,0720



HEAT TREATMENT

SOLUTION ANNEALED 1100 °C HOLDING TIME >=1.5 MIN/MM WATER QUENCHED

= TESTS =		-----TENSION-----				--IMPACT TESTS--		HARDNESS			
NR.	TEST	T(°C)	MPA	R _m	R _p 0,2	R _p 1,0	A	Z	T(°C) MINIMUM	AVERAGE	HRB
40405	813809	20	603,0	303,0	345,0	58,8					85 86

TECHNOLOGICALS

FLATTENING TEST: GOOD
 FLARING TEST: GOOD
 RING EXPANDING TEST: GOOD

METALLURGICAL TEST

INTERGRANULAR CORROSION: A.262 PRACT. "E" / ISO 3651-2 : NOT OBJECTIONS

NON DESTRUCTIVE TEST

100 % HYDROSTATIC PRESSURE TESTED AT 80 BAR , DURING 6 SEC, GOOD
 STEEL GRADE CHECKING ON EACH TUBE BY SPECTROMETRY (PMI): SATISFACTORY
 DIMENSIONAL CHECKING ON EACH TUBE, SATISFACTORY
 VISUAL INSPECTION ON EACH TUBE, SATISFACTORY

OTHER MATERIAL SPECIFICATIONS

A-SA312M-06 ED.07/NF A49117-85 TP304-304L/Z2-Z6 CN 18.10-09

MARKS

TX2
 TUBACEX 21,34 X 3,73 1.4301-1.4306 H S 1 - EN 10216-5 TC1 1.4301-1.4306 CFD - NF A49-117 Z2-Z6 CN 18.10-09 - A-SA 312 TP304-304L SMUS
 HEAT/..... PMI TX2 SPAIN

REMARKS

TOL.ISO T32 D3/T3
 MATERIAL MANUFACTURER APPROVED WITH CERTIFICATE NR. 07/2001/MUC BY TÜV SÜDDEUTSCHLAND (NOTIFIED BODY 0036) TO ISSUE CERTIFICATES OF SPECIFIC PRODUCT CONTROL IN ACCORDANCE WITH PRESSURE EQUIPMENT DIRECTIVE 97/23/EC ANNEX 1 POINT 4.3. AS PER LETTER DATED 21.08.92 TÜV SÜDWEST DECLINES COUNTERSIGNING MATERIAL CHARACTERISTICS COMPLY WITH POINT 7.5 OF ANNEX I TO PED BY HAVING AN ELONGATION AFTER RUPTURE AT TENSILE TEST NO LESS THAN 14 % AND A BENDING RUPTURE ENERGY AT IMPACT TE



We hereby certify that the material herein described has been manufactured, sampled, tested and inspected in accordance with above standards and specifications and satisfies the order's requirements. This certificate is issued by a computerized system and it is valid without original signature. In case the owner of the certificate would release a copy of it, he must accept its conformity to the issued, assuming the responsibility for any misuse of T.T.I., S.A. not allowed use. Any forgery or falsification of this certificate shall legally prosecuted.

T.T.I.
 Tubacex Tubos Inoxidables, S.A.

INGENIERIA DE CALIDAD



Juan Alvaro Zubizar



TUBACEX

T.T.I. - Tubacex Tubos Inoxidables, S.A.

Registro Mercantil de Aleva, Tomo 587, Folio 189, Hoja VI 2005 - N.I.F. A-01148227

Printed on:
19.01.2009

INSPECTION CERTIFICATE

EN 10204 3.1

Number: 417490
Page: 2 / 2

Rev: 0

Date: 19.12.2008

19.12.2008

CUSTOMER : PO : **C02647** OUR REFERENCE: **J9378**
 STANDARD : **DIN 17458 PK1/EN 10216-5 TC1 AD-2000 W2/W10/TRD100**
 ADDIT. SPECS : **NACE MR01.75-03 / ISO 15156**
 GRADE : **1.4301/1.4306**
 DIMENSIONS : **21,34 X 3,73**
 MATERIAL : **SEAMLESS STAINLESS STEEL TUBE**
COLD ROLLED; PASSIVATED;
PLAIN ENDS SQUARE CUT;

ST NO LESS THAN 27 J AT 20°C.

CONFORME ALL'ORIGINALE
RUBIVAL INOX S.R.L.



We hereby certify that the material herein described has been manufactured, sampled, tested and inspected in accordance with above standards and specifications and satisfies the order's requirements.
The certificate is issued by a computerized system and it is valid without original signature.
In case the owner of the certificate would release a copy of it, he must attend its conformity to the issued, assuming the responsibility for any error or T.T.I. S.A. not identical use.
Any forgery or falsification of this certificate shall legally prosecuted.

T.T.I.
Tubacex Tubos Inoxidables, S.A.

INGENIERIA DE CALIDAD

[Signature]
Joni Alzola Zubizarreta

Allegato 10:

Lista materiali certificati: Disegno 074-00-01rev3 tav. 10, EBT scambiatore

Assieme

IMPIANTO PROVA BARRE

N° Riferimento Disegno

074.00.01

Rev.:

3

Tav. 10 re v2

Data:

05/03/2010

Part. N°	Descrizione	Quantità	Lunghezza (mm)	Materiale	N° Certificato	Data Certificato	Fabbricante	N° di colata	Note
43a	Flangia WN 1" ansi 2500 LM	1	-	ASTM A182 F304	53/10-1	29/04/10	Steeltrade	374150	
43b	Flangia WN 1" ansi 2500 LF	1	-	ASTM A182 F304	53/10-1	29/04/10	Steeltrade	508471	
68/1	Tubo 1" sch.80	1	3672	ASTM AISI 304	425772	06/10/09	T.T.I. Tubacex	41659	

Compilato da:

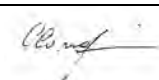

Data:

17/06/2010

CERTIFICATE OF CHEMICAL ANALYSIS AND MECHANICAL TEST.



STEELTRADE s.r.l.
 Loc. CATTAGNINA
 29010 ROTTOFRENO (PC) - ITALY
 TEL. +39 0523 780121
 FAX +39 0523 780123
 E-mail: inspection@steeltrade.it
 WEB: http://www.steeltrade.it

CERTIFICATE N. :53/10-1
 DATED :29/04/10

PURCHASER : SIET

YOUR ORDER : 74-10

JOB N. : ST 53/10

ITEM	Q.TY N°	DESCRIPTION	MATERIAL	HEAT CODE	HEAT
ITEM 01	4	WN FLANGE 1" LARGE MALE SCH.80 ANSI 2500	ASTM A182 F304	0B3	374150
ITEM 02	6	WN FLANGE 1" LARGE FEMALE SCH.80 ANSI 2500	ASTM A182 F304	B540	508471
ITEM 03	1	SLIP ON FLANGE 3" RF CL150	ASTM A182 F304	B248	259170
ITEM 04	1	SLIP ON FLANGE 2" RF CL150	ASTM A182 F304	B140	21728
ITEM 05	1	BLIND FLANGE 3" RF CL600 FORATA DIAM. 61 mm	ASTM A182 F304	B254	444625
ITEM 06	1	BLIND FLANGE 2" RF CL150 FORATA DIAM. 34 mm	ASTM A182 F304	B266	D82126A
ITEM 07	8	WN FLANGE 2" LARGE MALE SCH.160 ANSI 2500	ASTM A182 F304	B500	379250
ITEM 08	9	WN FLANGE 2" LARGE FEMALE SCH.160 ANSI 2500	ASTM A182 F304	B500	379250
ITEM 09	1	WN FLANGE 3/4" LARGE MALE SCH.160 ANSI 2500	ASTM A182 F304	B273	291450
ITEM 10	1	WN FLANGE 3/4" LARGE FEMALE SCH.160 ANSI 2500	ASTM A182 F304	B273	291450

Chemical Analysis

HEAT	C%	Mn%	Si%	P%	S%	Mo%	Cr%	Ni%	V%	Cu%	Ti%	Nb%	C.eq% *
374150	0.023	1.78	0.35	0.0028	0.0021		18.43	8.91					
508471	0.009	1.12	0.40	0.028	0.0026		18.14	9.12					
259170	0.014	1.75	0.31	0.026	0.024		18.33	8.14					
21728	0.017	0.77	0.32	0.028	0.002		18.25	9.20					
444625	0.013	1.10	0.41	0.026	0.026		18.20	9.22					
D82126A	0.019	1.61	0.42	0.025	0.025		18.26	10.17					
379250	0.022	1.71	0.24	0.03	0.021		18.22	8.93					
291450	0.022	1.76	0.31	0.029	0.026		18.32	8.20					

Mechanical Properties

HEAT	TENSILE TEST					IMPACT TEST					
	Tensile strength N/mm2	Yield point N/mm2	Elongation 2" %	Red. of Area %	Hardness HB	Type	Section	Temp.	Values J	Values J	Values J
374150	606	341	47.2	60.3							
508471	549	348	52.6	74.8							
259170	582	241	61.0	70.4							
21728	525	375	49.0	73.0							
444625	577	278	57.0	69.0							
D82126A	576	242	53.0	71.0							
379250	576	281	57.0	72.6							
291450	580	274	59.7	75.0							

NOTE:

- CERTIFICATE CONFORM TO : EN 10204.3.1
- STEEL MADE BY ELECTRIC FURNACE
- HEAT TREATMENT : SOLUTION ANNEALED
- ACCORDING TO PED 97/23/EC ANNEX 1 PAR.4.3
- PMI : NO OBJECTION (100% TESTED WITH NITON ANALYZER)
- DIMENSIONS : ASME B16.5
- VISUAL AND DIMENSIONAL TEST : SATISFACTORY

Quality Control
STEELTRADE



*C. eq. by long formula

The present certificate is in fully accordance with UNI CEI EN 45014-90



T.T.I. - Tubacex Tubos Inoxidables, S.A.

Registro Mercantil de Alava, Tomo 687, Folio 188, Hoja VI 2888 - N.I.F. A-41140227

Printed
19.01.

INSPECTION CERTIFICATE

EN 10204 3.1

Number: 417490
Page: 1 / 2

Rev: 6

Date: 19.12.2008

19.12.2008

CUSTOMER : PO : C02647 OUR REFERENCE: J9378
 STANDARD : DIN 17450 PK1/EN 10216-5 TC1 AD-2000 W2/W10/TRD100
 ADDIT. SPECS : NACE MR01.75-03 / ISO 15156
 GRADE : 1.4301/1.4306
 DIMENSIONS : 21,34 X 3,73
 MATERIAL : SEAMLESS STAINLESS STEEL TUBE
 COLD ROLLED; PASSIVATED;
 FLAIN ENDS SQUARE CUT;

---ITEM---	---HEAT---	NO. OF	---WEIGHT---	---TOTAL LENGTH---	---UNIT LENGTH---
YOUR	TTI.	PIECES	KG		
	3 40405	113	1152	686,90	5,5 - 6,5 MT

RAW MATERIAL

MELTING PROCESS: ELECTRIC FURNACE + A.O.D FROM: ACERALAVA
 PEELED BARS; MACROETCH TESTING: GOOD;

CHEMICAL COMPOSITION (*1 L: LADLE; C: PRODUCT)

*1 HEAT	C	Mn	Si	P	S	Ni	Cr	Cu	B	N
L 40405	0,012	1,49	0,290	0,032	0,0010	10,15	18,25	0,34	0,0009	0,0720



HEAT TREATMENT

SOLUTION ANNEALED 1100 °C HOLDING TIME >=1.5 MIN/MM WATER QUENCHED

= TESTS =		-----TENSION-----				--IMPACT TESTS--		HARDNESS			
NR.	TEST	T(°C)	MPA	R _m	R _p 0,2	R _p 1,0	A	Z	T(°C) MINIMUM	AVERAGE	HRB
40405	813809	20	603,0	303,0	345,0	58,8					85 86

TECHNOLOGICALS

FLATTENING TEST: GOOD
 FLARING TEST: GOOD
 RING EXPANDING TEST: GOOD

METALLURGICAL TEST

INTERGRANULAR CORROSION: A.262 PRACT. "E" / ISO 3651-2 : NOT OBJECTIONS

NON DESTRUCTIVE TEST

100 % HYDROSTATIC PRESSURE TESTED AT 80 BAR , DURING 6 SEC, GOOD
 STEEL GRADE CHECKING ON EACH TUBE BY SPECTROMETRY (PMI): SATISFACTORY
 DIMENSIONAL CHECKING ON EACH TUBE, SATISFACTORY
 VISUAL INSPECTION ON EACH TUBE, SATISFACTORY

OTHER MATERIAL SPECIFICATIONS

A-SA312M-06 ED.07/NF A49117-85 TP304-304L/Z2-Z6 CN 18.10-09

MARKS

TX2
 TUBACEX 21,34 X 3,73 1.4301-1.4306 H S 1 - EN 10216-5 TC1 1.4301-
 1.4306 CFD - NF A49-117 Z2-Z6 CN 18.10-09 - A-SA 312 TP304-304L SMUS
 HEAT/..... PMI TX2 SPAIN

REMARKS

TOL.ISO T32 D3/T3
 MATERIAL MANUFACTURER APPROVED WITH CERTIFICATE NR. 07/2001/MUC BY TÜV SÜDDEUTSCHLAND
 (NOTIFIED BODY 0036) TO ISSUE CERTIFICATES OF SPECIFIC PRODUCT CONTROL IN
 ACCORDANCE WITH PRESSURE EQUIPMENT DIRECTIVE 97/23/EC ANNEX 1 POINT 4.3.
 AS PER LETTER DATED 21.08.92 TÜV SÜDWEST DECLINES COUNTERSIGNING
 MATERIAL CHARACTERISTICS COMPLY WITH POINT 7.5 OF ANNEX I TO PED BY HAVING AN ELONGATION
 AFTER RUPTURE AT TENSILE TEST NO LESS THAN 14 % AND A BENDING RUPTURE ENERGY AT IMPACT TE



We hereby certify that the material herein described has been manufactured, sampled, tested and inspected in accordance with above standards and specifications and satisfies the order's requirements.
 This certificate is issued by a computerized system and it is valid without original signature.
 In case the owner of the certificate would release a copy of it, he must accept its conformity to the issued, assuming the responsibility for any misuse of T.T.I., S.A. not allowed use.
 Any forgery or falsification of this certificate shall legally prosecuted.

T.T.I.
 Tubacex Tubos Inoxidables, S.A.

INGENIERIA DE CALIDAD



Juan Alana Zubizarain



TUBACEX

T.T.I. - Tubacex Tubos Inoxidables, S.A.

Registro Mercantil de Aleva, Tomo 587, Folio 189, Hoja VI 2005 - N.I.F. A-01148227

Printed on:
19.01.2009

INSPECTION CERTIFICATE

EN 10204 3.1

Number: 417490
Page: 2 / 2

Rev: 0

Date: 19.12.2008

19.12.2008

CUSTOMER : PO : **C02647** OUR REFERENCE: **J9378**
 STANDARD : **DIN 17458 PK1/EN 10216-5 TC1 AD-2000 W2/W10/TRD100**
 ADDIT. SPECS : **NACE MR01.75-03 / ISO 15156**
 GRADE : **1.4301/1.4306**
 DIMENSIONS : **21,34 X 3,73**
 MATERIAL : **SEAMLESS STAINLESS STEEL TUBE**
COLD ROLLED; PASSIVATED;
PLAIN ENDS SQUARE CUT;

ST NO LESS THAN 27 J AT 20°C.

CONFORME ALL'ORIGINALE
RUBIVAL INOX S.R.L.



We hereby certify that the material herein described has been manufactured, sampled, tested and inspected in accordance with above standards and specifications and satisfies the order's requirements.
The certificate is issued by a computerized system and it is valid without original signature.
In case the owner of the certificate would release a copy of it, he must attend its conformity to the issued, assuming the responsibility for any error or T.T.I. S.A. not identical use.
Any forgery or falsification of this certificate shall legally prosecuted.

T.T.I.
Tubacex Tubos Inoxidables, S.A.

INGENIERIA DE CALIDAD

[Signature]
Joni Alzola Zubizarreta

Allegato 11:

Lista materiali certificati: Disegno 074-00-01rev3 tav. 13, tenuta

Assieme

IMPIANTO PROVA BARRE

N°Riferimento Disegno

074.00.01

Rev.:

3

Tav. 13rev. 3

Data:

09/04/2010

Part. N°	Descrizione	Quantità	Lunghezza (mm)	Materiale	N° Certificato	Data Certificato	Fabbricante	N° di colata	Note
1	Flangia inferiore RPV Ø 160 H= 80 mm	1		ASTM AISI 304	MEST8517 11/2010	23/03/10	Valbruna	247813	
2	Involucro da barra forata Ø 63/36 H= 457 mm	1	-	ASTM AISI 304	2009/2344	14/01/10	Centravis	94376	
3	Tubo 2" sch.160	1	324	ASTM AISI 304	428723	06/10/09	T.T.I. Tubacex	41544	
4	Flangia WN 2" ansi 2500 LF	1	-	ASTM A182 F304	53/10-1	29/04/10	Steeltrade	379250	
9	Flangia di chiusura Ø 160 H=170 mm	1	-	ASTM AISI 304	MEST8517 11/2010	23/03/10	Valbruna	247813	

Compilato da:



Data:

17/06/2010

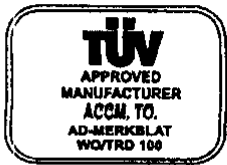

Centravis Production Ukraine

53201 56, Trubnikov Avenue Nikopol Dnepropetrovsk Region Ukraine tel/fax (05662) 2-51-94

Approved acc. to AD 2000-Merkblatt W0 by TÜV Nord e. V. and certified acc. to Pressure Equipment Directive (97/23/EC) by TÜV CERT-Certification body for pressure equipment of the TÜV NORD GRUPPE; notified body, reg.-no. 0045.

Сертифицирован по AD 2000 WO ТЮФ Норд и по директиве для напорных резервуаров высокого давления (97/23/ЕС) сертификационным центром ТЮФ CERT для оборудования, работающего под давлением сертификационного общества ТЮФ НОРД ГРУППЕ

Регистрационный номер сертификационного центра 0045

Требования Сертификата/ Inspection Certificate EN 10204 3.1+PED 97/23EC	Сертификат приемочных испытаний №/ Material Test Certificate No. 2009/2344	Лист/Page 1	Листов/Pages 2
Заказчик Customer Страна назначения Country of destination Адрес Address Контракт №/Contract No.			

ТЕХНИЧЕСКИЕ ТРЕБОВАНИЯ / TECHNICAL REQUIREMENTS

Наименование продукции/Goods' description

ТРУБЫ БЕСШОВНЫЕ ГОРЯЧЕДЕФОРМИРОВАННЫЕ ИЗ АУСТЕНИТНЫХ НЕРЖАВЕЮЩИХ МАРОК СТАЛИ/
HOT FINISHED SEAMLESS STAINLESS AUSTENITIC STEEL TUBES

НТД/Specification

ASTM A312-08 / ASME SA 312-07 / EN 10216-5
TC1; NACE MR-0175-2003.

Способ выплавки/Melting process EAF + AOD Класс стали: аустенитная	Маркировка/Marking
--	--------------------

Состояние поставки / State of delivery

annealed , pickled and passivated HFD
наружный диаметр (OD) -0/+2% (минимум 1 мм)
внутренний диаметр (ID) -2/+0% (минимум 1 мм)
(ID) -2/+0% (min 1 mm)

штамп контролера / inspector's stamp

COPTAMENT / RANGE OF SIZES							Гидроиспытания/ Hydr. test MPa (t=5sec.)
номер партии, Lot	марка стали/ Steel grade	плавка/ Heat No.	штуки/ Pieces	метраж/ Total Length, m	вес нетто, кг Net weight, kg	размеры/Dimensions, mm	
243	TP304/TP304L/ 1.4301/1.4306	94376	8	34,28	642	OD 63 x 32 ID x 15,5 WT x 4000-7000	OK
TOTAL:			8	34,28	642		

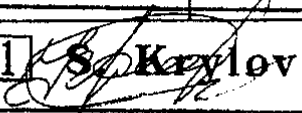
ЭИ 

дата / date 13.11.2009

эксперт/inspector

COPIA CONFORME ALL'ORIGINALE
RUBIVAL INOX S.R.L.

Требования Сертификата Inspection Certificate EN 10204 3.1+PED 97/23EC	Сертификат приемочных испытаний № Material Test Certificate No. 2009/2344	Лист/Page 2	Листов/Pages 2
--	--	----------------	-------------------

ДОЛЯ ХИМИЧЕСКИХ ЭЛЕМЕНТОВ, В % / CHEMICAL COMPOSITION, %

плавка № Heat No.	C	Mn	Si	P	S	Cr	Ni	N	Mo	Cu	B
94376	0,017	1,06	0,34	0,032	0,020	18,20	10,20	0,07			

РЕЗУЛЬТАТЫ ИСПЫТАНИЙ / TEST RESULTS

МЕХАНИЧЕСКИЕ ИСПЫТАНИЯ / MECHANICAL TESTS ACC. TO EN 10002-1,-5

партия/ Lot No.	плавка/ Heat No.	№ образца испытаний Specimen No.	направление испытаний/ Test direction	темпе- ратура- испытаний/ Test temperature, °C	предел теку- чести/ Yield strength, 0,2% MPa	предел текучес- ти/ Yield strength, 1% MPa	прочность при растяжен ии Tensile strength, MPa	удлине- ние Elongation %	твердость/ Brinell Hardness, HRB
243	94376	1 2	L	20°	381 402	419 434	579 574	50 50	84 87

Результаты микроструктуры/
Microstructure results не проводились
n/a

Технологические испытания/
Technological tests сплющивание / расширение кольца - удовлетворительно.
flattening / ring tensile test – acceptable

Испытания на межкристаллитную коррозию/
Intergranular corrosion test ASTM A 262 , практика E, EN ISO 3651-2, практика A - удовлетворительно.
ASTM A 262, practice E, EN ISO 3651-2, practice A – acceptable.

Неразрушающий контроль/
Non-destructive test method 100% гидроиспытания – удовлетворительно.
100% hydro-tested – acceptable.

Термообработаны. Режим термообработки -1080°C, охлаждение в воде 5 минут./
Tubes are heat treated: 1080° C holding time 5 minutes then cooled by water.

100% Визуальный контроль, проверка размеров и несмешивание марок /
100% VISUAL INSPECTION, DIMENSIONAL MEASUREMENT AND POSITIVE MATERIAL IDENTIFICATION – SATISFACTORY.

Эксцентриситет (отклонение центра) максимум 10% от номинальной толщины стенки.
Excentricity max. 10% of average w.t.

Трубы на момент погрузки не содержат Ртуть, Радий, Альфа частицы и легкоплавкие элементы.
The tubes when shipped are free from contamination by Mercury, Radium, Alpha Source and low melting elements.

В процессе производства, монтажа и тестирования ртуть, ртутные смеси и оборудование с содержанием ртути не были использованы ни одним из способов, что могло бы привести к ее содержанию в трубах.
No mercury, mercury compounds or mercury bearing instruments and/or equipment have been used in any manner that might have caused contamination in manufacture, assembly or test of the material.

Трубы не ремонтировались сваркой.
No weld repair.

ЗАО «СЕНТРАВИС ПРОДАКШН УКРЕЙН» гарантирует, что трубы, указанные в данном сертификате качества, были произведены в соответствии с требованиями заказа.
CENTRAVIS PRODUCTION UKRAINE CJSC declares that the tubes described herein have been manufactured in accordance with the order requirements.

дата / date 13.11.2009

эксперт/inspector

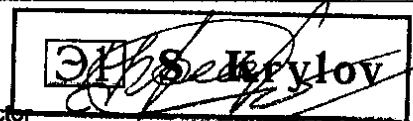



T.T.I. - Tubacex Tubos Inoxidables, S.A.

Registro Mercantil de Alava, Tomo 587, Folio 198, Hoja VI 2886 - N.I.F. A-01140227

Printed on:
21.10.2009

INSPECTION CERTIFICATE

EN 10204 3.1

Number: 428723

Page: 1 / 2

Rev: 0

Date: 06.10.2009

06.10.2009

CUSTOMER : PO : **C02989*** OUR REFERENCE: **K0002**
 STANDARD : **EN 10216-5 TC2**
 ADDIT. SPECS : **NACE MR01.75-03 / NACE MR03-03 / ISO 15156-3**
 GRADE : **1.4301/1.4306**
 DIMENSIONS : **60,32 X 8,74**
 MATERIAL : **SEAMLESS STAINLESS STEEL TUBE**
COLD ROLLED; PICKLED-PASSIVATED;
PLAIN BEVELLED ENDS;

ITEM	HEAT	NO. OF	WEIGHT	TOTAL LENGTH	UNIT LENGTH	
YOUR	TTI.	PIECES	KG			
	66	41544	28	1933	172,52	5,5 - 6,5 MT

RAW MATERIAL

MELTING PROCESS: ELECTRIC FURNACE + A.O.D FROM: ACERALAVA
 PEELED BARS; MACROETCH TESTING: GOOD;

CHEMICAL COMPOSITION (*1 L: LADLE; C: PRODUCT)

*1 HEAT	C	Mn	Si	P	S	Ni	Cr	N
L 41544	0,017	1,50	0,300	0,027	0,0010	10,15	18,30	0,0720

HEAT TREATMENT

SOLUTION ANNEALED 1100 °C HOLDING TIME >=1.5 MIN/MM WATER QUENCHED

TESTS		TENSION				IMPACT TESTS		HARDNESS	
NR.	NR.	T(°C)	MPA	RP 0,2	RP 1,0	A	Z	T(°C) MINIMUM AVERAGE	HRB
HEAT	TEST								
41544	908135	20	550,0	321,0	369,0	46,7			81 82
41544	908135A	20	550,0	322,0	369,0	45,3			81 82

TECHNOLOGICALS

FLATTENING TEST: GOOD
 RING EXPANDING TEST: GOOD

METALLURGICAL TEST

INTERGRANULAR CORROSION: A262 "E"/ISO 3651-2/ 5 TEST ACC.MIL-P-1144D+24691/3: GOOD

NON DESTRUCTIVE TEST

100 % U.T TO EN10246-7 (ENT.5%, MIN.0,3MM) , GOOD
 100 % EDDY CURRENT TEST AT E-426 , GOOD
 100 % HYDROSTATIC PRESSURE TESTED AT 80 BAR , DURING 5 SEC, GOOD
 STEEL GRADE CHECKING ON EACH TUBE BY SPECTROMETRY (PMI): SATISFACTORY
 DIMENSIONAL CHECKING ON EACH TUBE, SATISFACTORY
 VISUAL INSPECTION ON EACH TUBE, SATISFACTORY



OTHER MATERIAL SPECIFICATIONS

A/SA312M-08A ED.07 + 08 ADD TP304-304L
 A/SA376M-06 ED.07 + 08 ADD TP304

MARKS

TX2
 TUBACEX 60,32 X 8,74 EN 10216-5 TC2 1.4301-1.4306 CFD ASTM-ASME
 A-SA 312 TP304-304L A-SA 376 TP304 SMLS HEAT/..... PMI TX2
 SPAIN

REMARKS

TOL. ISO 1127 D3-T3 / ASTM A999
 NO WELD REPAIR WAS PERFORMED

COPIA CONFORME ALL'ORIGINALE



We hereby certify that the material herein described has been manufactured, sampled, tested and inspected in accordance with above standards and specifications and satisfies the order's requirements.
 This certificate is issued by a computerized system and it is valid without original signature. In case the owner of this certificate would request a copy of it, he must advise its conformity to the issuer, assuming the responsibility for any unlawful or T.T.I.,S.A. not allowed use.
 Any forgery or falsification of this certificate shall legally prosecuted.

T.T.I.
 Tubacex Tubos Inoxidables, S.A.

INGENIERIA DE CALIDAD

[Signature]
 JON ARBIDE ZUBEROA



T.T.I. - Tubacex Tubos Inoxidables, S.A.

Registro Mercantil de Álava, Tomo 587, Folio 188, Hoja VI 2886 - N.I.F. A-61140227

Printed on:
21.10.2009

INSPECTION CERTIFICATE

EN 10204 3.1

Number: 428723
Page: 2 / 2

Rev: 0

Date: 06.10.2009 06.10.2009

CUSTOMER : PO : **C02989*** OUR REFERENCE: **K0002**

STANDARD : **EN 10216-5 TC2**

ADDIT. SPECS : **NACE MR01.75-03 / NACE MR03-03 / ISO 15156-3**

GRADE : **1.4301/1.4306**

DIMENSIONS : **60,32 X 8,74**

MATERIAL : **SEAMLESS STAINLESS STEEL TUBE**
COLD ROLLED; PICKLED-PASSIVATED;
PLAIN BEVELLED ENDS;

MATERIAL MANUFACTURER APPROVED WITH CERTIFICATE NR. 07/2001/MUC BY TÜV SÜDDEUTSCHLAND (NOTIFIED BODY 0036) TO ISSUE CERTIFICATES OF SPECIFIC PRODUCT CONTROL IN ACCORDANCE WITH PRESSURE EQUIPMENT DIRECTIVE 97/23/EC ANNEX 1 POINT 4.3. MATERIAL CHARACTERISTICS COMPLY WITH POINT 7.5 OF ANNEX I TO PED BY HAVING AN ELONGATION AFTER RUPTURE AT TENSILE TEST NO LESS THAN 14 % AND A BENDING RUPTURE ENERGY AT IMPACT TEST NO LESS THAN 27 J AT 20°C.



We hereby certify that the material herein described has been manufactured, sampled, tested and inspected in accordance with above standards and specifications and satisfies the order's requirements.

This certificate is issued by a computerized system and it is valid without original signature. In case the owner of the certificate would release a copy of it, he must state its conformity to the issued, assuming the responsibility for any untruth or T.T.I.S.A. not allowed use.

Any forgery or falsification of this certificate shall legally prosecuted.

T.T.I. Tubacex Tubos Inoxidables, S.A.

INGENIERIA DE CALIDAD

[Signature]
Jon Albano Zubizarreta

CERTIFICATE OF CHEMICAL ANALYSIS AND MECHANICAL TEST.



STEELTRADE s.r.l.
 Loc. CATTAGNINA
 29010 ROTTOFRENO (PC) - ITALY
 TEL. +39 0523 780121
 FAX +39 0523 780123
 E-mail: inspection@steeltrade.it
 WEB: http://www.steeltrade.it

CERTIFICATE N. :53/10-1
 DATED :29/04/10

PURCHASER : SIET

YOUR ORDER : 74-10

JOB N. : ST 53/10

ITEM	Q.TY N°	DESCRIPTION	MATERIAL	HEAT CODE	HEAT
ITEM 01	4	WN FLANGE 1" LARGE MALE SCH.80 ANSI 2500	ASTM A182 F304	0B3	374150
ITEM 02	6	WN FLANGE 1" LARGE FEMALE SCH.80 ANSI 2500	ASTM A182 F304	B540	508471
ITEM 03	1	SLIP ON FLANGE 3" RF CL150	ASTM A182 F304	B248	259170
ITEM 04	1	SLIP ON FLANGE 2" RF CL150	ASTM A182 F304	B140	21728
ITEM 05	1	BLIND FLANGE 3" RF CL600 FORATA DIAM. 61 mm	ASTM A182 F304	B254	444625
ITEM 06	1	BLIND FLANGE 2" RF CL150 FORATA DIAM. 34 mm	ASTM A182 F304	B266	D82126A
ITEM 07	8	WN FLANGE 2" LARGE MALE SCH.160 ANSI 2500	ASTM A182 F304	B500	379250
ITEM 08	9	WN FLANGE 2" LARGE FEMALE SCH.160 ANSI 2500	ASTM A182 F304	B500	379250
ITEM 09	1	WN FLANGE 3/4" LARGE MALE SCH.160 ANSI 2500	ASTM A182 F304	B273	291450
ITEM 10	1	WN FLANGE 3/4" LARGE FEMALE SCH.160 ANSI 2500	ASTM A182 F304	B273	291450

Chemical Analysis

HEAT	C%	Mn%	Si%	P%	S%	Mo%	Cr%	Ni%	V%	Cu%	Ti%	Nb%	C.eq% *
374150	0.023	1.78	0.35	0.0028	0.0021		18.43	8.91					
508471	0.009	1.12	0.40	0.028	0.0026		18.14	9.12					
259170	0.014	1.75	0.31	0.026	0.024		18.33	8.14					
21728	0.017	0.77	0.32	0.028	0.002		18.25	9.20					
444625	0.013	1.10	0.41	0.026	0.026		18.20	9.22					
D82126A	0.019	1.61	0.42	0.025	0.025		18.26	10.17					
379250	0.022	1.71	0.24	0.03	0.021		18.22	8.93					
291450	0.022	1.76	0.31	0.029	0.026		18.32	8.20					

Mechanical Properties

HEAT	TENSILE TEST					IMPACT TEST					
	Tensile strength N/mm2	Yield point N/mm2	Elongation 2" %	Red. of Area %	Hardness HB	Type	Section	Temp.	Values J	Values J	Values J
374150	606	341	47.2	60.3							
508471	549	348	52.6	74.8							
259170	582	241	61.0	70.4							
21728	525	375	49.0	73.0							
444625	577	278	57.0	69.0							
D82126A	576	242	53.0	71.0							
379250	576	281	57.0	72.6							
291450	580	274	59.7	75.0							

NOTE:

- CERTIFICATE CONFORM TO : EN 10204.3.1
- STEEL MADE BY ELECTRIC FURNACE
- HEAT TREATMENT : SOLUTION ANNEALED
- ACCORDING TO PED 97/23/EC ANNEX 1 PAR.4.3
- PMI : NO OBJECTION (100% TESTED WITH NITON ANALYZER)
- DIMENSIONS : ASME B16.5
- VISUAL AND DIMENSIONAL TEST : SATISFACTORY

Quality Control
STEELTRADE



*C. eq. by long formula

The present certificate is in fully accordance with UNI CEI EN 45014-90

Allegato 12:

Documentazione valvola di sicurezza

CERTIFICATO DI COLLAUDO 3.1
EN 10204: 2004
N° 10-437
REV. 0
DEL 12/05/10

COMMESSA N° 10-437
DEL 08/04/10
MATRICOLA VALVOLA 10-437

CLIENTE: **SIET SRL**
ORDINE N° 46

DEL 02/04/10

Valvola di sicurezza in accordo alla Direttiva 97/23/CE - categoria: IV - fluidi: gruppo I e II allo stato gas, vapore e liquido
Organismi notificati: Pascal n. 1115 (modulo H1 e modulo D)
Norme e regolamenti di riferimento: "Raccolta E" - ISPEL (1979) - EN ISO 4126-1 (2004)

DESCRIZIONE DEL PRODOTTO E SUE CARATTERISTICHE

Modello **249-I** Con incastellatura tipo Chiuso Cappuccio H2 peso: 3 kg

Coeff. di efflusso **Kd**- 0,85 Coeff. di efflusso ridotto **Kdr**- ($Kd \times 0,9$) = 0,77

Fatt. riduz. della portata **Kb** (dovuto alla contropressione) = 1,00

Fattore di riduz. della portata **Kv** (dovuto alla viscosità) – solo liquidi = /

Lato Entrata: DN 1" Tipo di connessione: Fil. Gas/M Pressione di progetto: PS 209,00 barg a TS Max.
Lato Uscita: DN 1 1/2 Tipo di connessione: Fil. Gas/F Pressione di progetto: PS 63,00 barg a TS Max.

Temperatura di progetto TS: -50,00°C + 400,00°C

Diametro orificio do: 6 mm Area orificio: 28,27 mm² Alzata otturatore: 2,90 mm

Pressione di taratura: 172,50 barg Sovrapressione: 10% Scarto di chiusura: 10%

Capacità di scarico: **2349** Kg/h

Fluido: ACQUA Stato fisico: Vapore saturo
Temperatura di scarico: 361,76 °C

Mat. Corpo: ASTM 316 Mat. Cappello: ASTM A351 CF8M
Mat. molla: INCONEL X750 Codice molla: BIN 10347
Mat. sede: ASTM 316 STELL. Campo di regolazione molla: 170,0 + 200,0 barg
Mat. Otturatore: ASTM 316 STELL. Mat. Asta: ASTM 316
Mat. piattello guida: ASTM 316 Mat. soffietto di bilanciamento: /
Mat. camicia di riscaldamento: /
Press. di progetto PS: / Temp. progetto TS: /
Tipo tenuta: metallica

PROVE – CONTROLLI – COLLAUDI (Rif. Procedura PRO 10) del mostro

Prova idraulica secondo "EN ISO4126-1" con liquido a: 600 barg (lato entrata), 86,9 barg (lato uscita) :	ESEGUITA
Prova di taratura al banco in acc. a Istruzione operativa IST13 con aria a 172,50 barg contropressione atmosferica e temperatura ambiente:	ESEGUITA
Prova di tenuta sede-otturatore secondo "API RP527 " con aria a 155,25 barg:	ESEGUITA
Controllo dimensionale e visivo secondo "ISTRUZIONE BESA":	ESEGUITO
RISULTATO DEL COLLAUDO: SODDISFACENTE	
Le Procedure e le Istruzioni operative di riferimento sono state verificate Ed approvate dall'Organismo Notificato competente (PASCAL n°1115)	

BESA Ing. Santangelo S.p.A.

La valvola di sicurezza deve essere installata, usata e manutenzionata secondo le istruzioni indicate nel Manuale d'Uso e Manutenzione.
Avvertenza: la manutenzione di questa valvola di sicurezza deve essere eseguita da personale autorizzato da BESA S.p.A.
Ogni intervento non autorizzato, determina la cessazione della responsabilità di BESA S.p.A.

BESA Ing. Santangelo S.p.A.

DICHIARAZIONE DI CONFORMITA' DECLARATION OF CONFORMITY



In accordo alla direttiva europea 97/23/CE

According to european directive 97/23/EC

Attrezzatura a pressione <i>Pressure equipment</i>		Esame CE del progetto <i>EC design- examination</i>		
Valvole di sicurezza Serie 249 <i>Safety valves Series 249</i>		DAC-12-97/23/CE-H1		
Modello* <i>Type*</i>	Dimensioni nominali <i>Nominal sizes</i>	Organismo notificato <i>Notified body</i>	N° identificazione <i>Identification No.</i>	N° certificato <i>Certificate No.</i>
249	DN 1/2"x1" + DN 1"x1"1/2	PASCAL	1115	314/H1-97/23/CE

*Ciascun modello di valvola puo' essere individuato con una abbreviazione finale - G, C, Cr, I, L, X - in funzione del materiale del corpo.

*Every type of valve can be identified by a final abbreviation - G, C, Cr, I, L, X - relative to the body valve material.

Categoria IV

In accordo all'articolo 3 allegato II

According to article 3 annex II

Principali norme di riferimento:

Main standards:

EN 4126-1 (2004), prEN 12516-3 (2000), ASME B16.34 (1996), ASME Sez. VIII Div. 1 (2000), VSR ed. 1999 (rev. 1995), API 520 (2000)

Modulo <i>Module</i>	Procedure di valutazione della conformità <i>Conformity assessment procedures</i>	Numero certificato <i>Certificate number</i>
H1	Esame CE del progetto <i>EC design- examination</i>	314/H1-97/23/CE
D	Garanzia qualità produzione <i>Production quality assurance</i>	003 - 97/23/CE - D

Procedure di valutazione della conformità in accordo all'articolo 10

Conformity assessment procedures according to article 10

PASCAL – N° identificazione (identification number) 1115

Via Scarsellini, 13 – 20161 MILANO / ITALIA

Nome e indirizzo dell'organismo notificato che verifica le procedure di valutazione della conformità'

Name and address of the notified body (monitoring a.m. conformity assessment procedures)

Con la presente, il costruttore dichiara che il progetto, la costruzione ed i collaudi delle suddette attrezzature a pressione, rispettano i requisiti della direttiva europea 97/23/CE.

By this declaration, the signing manufacturer confirms that the design, the manufacturing and the inspection of this pressure equipment meet the requirements of the pressure equipment directive 97/23/CE.

Besa Ing. Santangelo S.p.A

V.le delle Industrie Nord 1/A – 20090 Settala (MI)

09/02/10

data

nominativo del costruttore

Il legale rappresentante

date

manufacturer name

authorized

subscriber

Allegato 13:

Documentazione venturimetro

Customer (Cliente)	P.O. (Ordine)	Q.C.P. - I.T.P.	Tecnomatic Procedure	Plant (Impianto)	TM Job (Commissa N.)
S.I.E.T.	43-10				064-R10

RESULT (RISULTATI)

Quantity Pezzi	P.O. Item Ordine	Product (Prodotto)	Model/Tag (Modello/Signa)	Material (Materiale)	Test Pressure (Pressione di Prova)		
					Shell Test (Tenuta Corpo)	Seat Test (Tenuta Sede)	Outside (Esterna) Pneumatic (Pneumatica)
1	01	TUBO VENTURI DN 2" ANSI 2500 WN-LM /LF		AISI 304	260 BAR	/	/

TEST RESULT (ESITO DEL COLLAUDO)

Conforming (Conforme)	Purchaser's Inspector (Ispettore Cliente)			TM Inspector (Ispettore TM)
Not Conforming (Non Conforme)	Date (Data)			Date (Data)
	Attachment (Allegati)			27/04/2010
				

MATERIAL DETAIL (RIEPILOGO MATERIALI)N. 2/064-R10 Page 1 of 1

Customer (Cliente) S.I.E.T.		Order (Ordine) N. 43-10	TM Job (Commessa N.) 064-R10
Quality Plan No. (PFC N.)	Step (Fase)	Plant (Impianto)	

DESCRIPTION (DESCRIZIONE)

Drawing No. (Disegno N.)	Item (Pos)	Product (Prodotto)	Material (Materiale)	Heat No. (Colata N.)	Supplier (Fornitore)	Certificate Certificato
064-R10.D01	1	VENTURI BODY	AISI 304	98886	SIDENOR	1317772
"	2	FLANGE 2" ANSI 2500 WN-LF	AISI 304	247813	ACCIAIERIE VALBRUNA	851711/2010
"	3	FLANGE 2" ANSI 2500 WN-LM	AISI 304	247813	ACCIAIERIE VALBRUNA	851711/2010
"	4	PIPE 2" SCH. 160	AISI 304	41953	SIDENOR	1323295
"	5	PRESSURE TAPS 1/4"NPT-F	AISI 304	9RN6	ACCIAIERIE VALBRUNA	775434/2009

Tecnomatic Inspector (Ispettore TM) 	Purchaser's Inspector (Ispettore Cliente)	Authorized Inspector (Ispettore Ente Autorizzato)
Date (Data) 27/04/2010	Date (Data)	Date (Data)



COMM. 11-R08



SIDENOR

MILL TEST CERTIFICATE



Basauri Plant

ISO 9001 - ISO/TS 16949

CUSTOMER: TERNINOX, SPA	WORKS REFERENCE: 1317772
REFERENCE: 113934	SALES ORDER: 188229-10
PRODUCT NR:	HEAT NUMBER: 98886
	VERSION: 96659
	ROLLED: 05.12.2007

REQUIRED PRODUCT			
AISI304/304L(1.4301/1.4307) IM ROUND BARS TURNED SOLUTION ANNEALING 75 +0/+0,46 mm			
ISO X13 4.500/6.000 mm RANDOM			
EXPEDITION	DELIVERY: 80206362	WEIGHT (KG): 2.880	BUNDLES: 2
			UNITS: 14

MADE ACCORDING TO	
ASTM A276 - 2002 ; AD-W2 - 01.09.1998 ; AD-W10 - 01.11.1987 ; DIN 17440 - .09.1996	
ASTM A479-A479M - 2003 ; ASTM A182-A182M - 2007 ; EN 10088-3 - 01.04.1995	
ASME SA479-SA479M - 2004 ; ASME SA182-SA182M - 2001 ; NACE MR0175 2002 01.01.2002	
AISI STAINLESS STEELS - 01.03.1999 ; EN DIRECTIVA 97/23/CE:97 - 29.05.1997	
TERNINOX FICHA TECNICA ED1 1 29.10.2004 ; EN 10204 :2004 OCT. 2004 3.1	

CHEMICAL ANALYSIS OF HEAT									U: % HEAT NUMBER: 98886
	C	Mn	Si	P	S	Cr	Ni	N	
Min.					0,015	18,000	8,000		
Max.	0,030	2,000	0,750	0,045	0,030	19,500	10,000	0,1000	
cer.	0,020	1,840	0,346	0,020	0,024	18,200	8,070	0,0850	

MECHANICAL PROPERTIES AS SUPPLIED (CONDITIONS)	
Specimen Test location: At 12,5 mm from the surface ; Temperature of: (1): Solution annealing 1.040 °C	
Cooling: (1): Air	

MECHANICAL PROPERTIES AS SUPPLIED (TEST)	
Tensile test specimen direction (Longitudinal): Longitudinal	
Tensile Strength (S17/600 N/mm2): 614 N/mm2	
Yield Strength(1) (Rp(0.2%)) => 207 N/mm2 ; Rp(0.2%) 272 N/mm2	
Yield Strength(2) (1%) => 230 N/mm2 ; (1%) 318 N/mm2 ; Elongation ((5d)) => 45 % ; (5d) 56,2 %	
Reduction of Area (>= 50 %) : 72,9 % ; Notch impact sample direction (Longitudinal): Longitudinal	
Notch Impact sample type (ISO V) : ISO V ; Notch Impact test Temperature (20 °C) : 20 °C	
K(1) (>= 100 J) : 281 J ; K(2) : 277 J ; K(3) : 280 J ; Hardness (<= 215 HB) : 153 HB	

ADDITIONAL TESTS	
Standard (ASTM E112-96- . . .1996) ; Grain size: Austenitic 6 ; Standard (ASTM A262-01-2001)	
Type / Method (Practice E) ; Interglystalline Corrosion: O.K.	

TECNOMATIC S.p.A Quality Control	
WITNESSED <input type="checkbox"/>	REVIEWED <input checked="" type="checkbox"/>
Date	22/02/10
Signature	

CORPO VENTURI

TECHNOLOGY & QUALITY CERTIFIES THAT THE PRODUCT FULL FILLS THE ORDER'S SPECIFICATION		
APPROVED BY: MARCELINO GARCIA ZAVAS	Page 1 of 1	SIGN:
DATE: 20.12.2007		SIDENOR BAS AURI
REF.: 1981047700090		Metallurgical Technical Approval Level II



04-R10

36100 VICENZA (Italia) - Viale della scienza, 25 z.l.
 Stab.: 39100 BOLZANO (Italia) - Via A. Volta, 4

Cliente / Besteller/Purchaser/Cliant
 TM TECNOMATIC SPA
 VIA DELLE INDUSTRIE, 36
 26100-CREMONA-CR

Produttore: ACCIAIERIE VALBRUNA S.P.A.
 Hersteller/Hersteller/Usine producteur

Oggetto Prove: - Solubilizzato Pelato
 Prüfgegenstand/Item Inspected/Produitage

Avviso di Spedizione: A-
 Lieferungsgepäckung Art.B.L.

Ordine nr: VS ORDINE 216
 Bestell/Your order/Commande

Tipo di Elaborazione: E+AOD
 Bearbeitungsart/Welding process/Mode d'elaboration

Certificato nr: MEST851711/2010/
 Prüfung/Test/Essai

Conferma ordine nr: BS10000874
 Bestell/Our Order/Ref. nr.

Marchio di Fabbrica:
 Zeichen des Lieferwerkes
 Trade mark
 Signe de l'usine productrice

Funzione del Collaudatore:
 Stempel des Werkssachverständigen
 Inspector's stamp/Prinçipe de l'essayeur



Specifiche:

Anforderungen / Requirements / Exigences

VAL STOCK 2005 1.4307/304L A
 AMS 5639 H S30400 A
 AMS-QQ-S-763 B 304L A
 ASME SA193 2007 B8 CLASS1 a
 ASME SA320 2007 B8 CLASS1 s
 ASTM A182 2008A S30400 A a
 ASTM A262 2002A PRACTICE E
 ASTM A320 2008 B8 CLASS1
 DIN 17440 96 1.4301 A
 EN 10222-5 99 1.4301 A
 NACE MR0175* 2003 S30403 A b

(0) SEC.II PT.A 2007 EDITION
 (1) SEC.II PT.A 2007 EDITION
 (2) SEC.II PT.A 2007 EDITION
 (4) SEC.II PT.A 2007 EDITION
 (6) SEC.II PT.A 2007 EDITION
 (8) Chemical analysis only and mechanical properties.
 (A) * ISO 15156-3

AISI 304
 AMS 5647 H S30403 A
 ASME SA182 2007 S30400 A a
 ASME SA276 2007 S30400 A a
 ASME SA479 2007 S30400 A a
 ASTM A182 2008A S30403 A a
 ASTM A276 2008 S30400 A
 ASTM A479 2006A S30400 A
 EN 10088-3 2005 1.4301 A
 EN 10222-5 99 1.4307 A
 QQ-S-763 F 304 A

AISI 304L
 AMS-QQ-S-763 B 304 A
 ASME SA182 2007 S30403 A (1)
 ASME SA276 2007 S30403 A (4)
 ASME SA479 2007 S30403 A (7)
 ASTM A193 2008B B8 CLASS1
 ASTM A276 2008 S30403 A
 ASTM A479 2006A S30403
 EN 10088-3 2005 1.4307 A
 NACE MR0175* 2003 S30400 A (A)
 QQ-S-763 F 304L A

0Chemical analysis only and mechanical properties.
 1Chemical analysis only and mechanical properties.
 3SEC.II PT.A 2007 EDITION
 5SEC.II PT.A 2007 EDITION
 7SEC.II PT.A 2007 EDITION
 9Chemical analysis only and mechanical properties.
 B* ISO 15156-3

Qualità: 1.4307/304/304L
 Werkstoff/Grade/Qualité

Marca: MVAISL MAXIVAL
 Markenbezeichnung/Brand/Marque

Punzonatura: 1.4307/304/304L
 Kennzeichnung/Marking/Étiquette

TECNOMATIC S.p.A.
Quality Control
 WITNESSED REVIEWED
 Date: 23/04/10
 Signature: _____

Pos. nr. Pos. nr. Item nr. Nr. de poste	Oggetto Gegenstand Product description Description du produit	Dimensioni - mm Abmessungen Dimension Dimension	Tolleranza Toleranz Allowance Tolérance	Lunghezza - mm Länge Length Longueur	Colata Schmelze Heat Coulée	Pezzi Stückzahl Pieces Pièces	Peso - KG Gewicht Weight Poids	Lotto nr. Losn. Lot nr. Lot nr.
0010	Tondo	240,000	k12	4010 / 4010	247813		100,0	829602570

Sono state soddisfatte tutte le condizioni richieste
 Die gestellten Anforderungen sind b. Anlage erfüllt
 The material has been furnished in accordance with the requirements
 Le matériel a été livré conforme aux exigences

Controllo antimescolanza: OK
 Verwechslungprüfung: spezifiziert/analytisch durchgeführt
 Antiming testing performed: OK
 Contrôle antimeslange fait: r.a.s.

Controllo visivo e dimensionale: soddisfa le esigenze:
 Beschäftigung und Ausmessung: ohne Beanstandung
 Visual inspection and dimensional check/satisfactory
 Contrôle visuel et dimension: satisfaisant

TEST ALLO STATO DI FORNITURA
 Test on delivery condition Prüfung auf lieferbaren Produkt test a l'état de livraison Prueba sobre el material así como entregado

TEST	Provetta/Probes Specimen/Éprouvette Leg. diam. Ømm Bohle/Str. 10mm Wich. Diam. Thickness Leg. diam. ømm mm	°C	Snervamento Dehnung Yield Stress Limite élastique Rp 0,2% N/mm2	Snervamento Dehnung Yield Stress Limite élastique	Resistenza Zugfestigkeit Tensile strength Résistance à la traction Rm N/mm2	Allungamento Bruchdehnung Elongation Allongement E 4d %	Strizione Bruchdehnung Reduction of area Striction RA %	Resilienza Kerbschlagenergie Impact Value Resilience	Durezza Härte Rockwell Dureté HB
Valori richiesti 1 Anforderungen/Required values Valeurs dimensionées		min max	207	-	517 793	40	50	-	140 223
A	10	20 L	253		558	64	75		174

TEST	min	max
Dimensioni grano x ASTM E112		4

FRANGIE 2° W.N.L.F.
 AISI 2500 UN.L.M

TEST	Provetta/Probes Specimen/Éprouvette Ømm Bohle/Str. 10mm Wich. Diam. Thickness Leg. diam. ømm mm	°C	Snervamento Dehnung Yield Stress Limite élastique Rp 0,2% N/mm2	Snervamento Dehnung Yield Stress Limite élastique Rp 1% N/mm2	Resistenza Zugfestigkeit Tensile strength Résistance à la traction Rm N/mm2	Allungamento Bruchdehnung Elongation Allongement A5 %	Strizione Bruchdehnung Reduction of area Striction Z %	Resilienza Kerbschlagenergie Impact Value Resilience KV J	Durezza Härte Rockwell Dureté HB
Valori richiesti 1 Anforderungen/Required values Valeurs dimensionées		min max	200	230	500 700	35	-	60	- 215
B	10	20 T	231	265	546	59	65	109 104 102	174



36100 VICENZA (Italia) - Viale della scienza, 25 z.l.
Stab.: 39100 BOLZANO (Italia) - Via A. Volta, 4

Cliente / Besteller/Purchaser/Client
TM TECNOMATIC SPA
VIA DELLE INDUSTRIE, 36
26100-CREMONA-CR

Produttore: **ACCIAIERIE VALBRUNA S.P.A.**
Hersteller/Werks/Usine producer

Oggetto Prove: - Solubilizzato Pelato
Prüfgegenstand/Item inspected/Prüfung

Avviso di Spedizione: A-
Lieferungs/Packing list/W.L.

Ordine nr: VS ORDINE 216
Bestel/Your order/Commande

Tipo di Elaborazione: E+AOD
Erweiterung/Melting process/Mode of elaboration

Certificato nr: MEST851711/2010/
Prüfung/Teil/Sheet

Conferma ordine nr: BS10000874
Werk/Our Order/Nr.

Marchio di Fabbrica:
Zeichen des Lieferwerkes
Trade mark
Siglo de l' usine producer



Punzone del Collaudatore:
Stempel des Werkssachverständigen
Inspector's stamp/Prüfer von d. Inspektor



TE=longitudinale/längs, TS=transversale/quers, O=Oberseite/oberseitig

Analisi chimica

Chemische Zusammensetzung/Chemical Analysis/Analyse chimique

Colata / Heat Schmelze/Coulée	min - max 0,030	- 1,00	- 2,00	18,00 19,50	- 1,00	- 1,00	8,00 10,00	- -	0,040	- 0,030	0,100	- -	- -	- -	- -
	C %	Si %	Mn %	Cr %	Mo %	Cu %	Ni %	Co %	P %	S %	N %				
247813	0,016	0,65	1,91	18,30	0,56	0,44	8,35	0,100	0,028	0,030	0,089				

Intergranular corrosion test per ASTM A262 pract. E: ok.

I.Korrosion nach EN ISO 3651-2A Sensibilisierung : T1 : OK

Corrosion test per EN ISO 3651-2A sensitized T1 : OK

Melted and manufactured in Italy No welding or weld repair Material free from Mercury contamination

We declare that the finished product is checked for radioactive contamination through Portal System when it leaves the production plant.

The Quality Management System is Certified acc. Pressure Equipment Directive (97/23/EC) Annex 1, 4.3 by TÜEV and LLOYD' S

TECNOMATIC S.p.A Quality Control	
WITNESSED <input type="checkbox"/>	REVIEWED <input checked="" type="checkbox"/>
Date	27/04/10
Signature	<i>[Signature]</i>

Vicenza, 23/03/10

V00012
IMD, MCEP

il collaudatore di stabilimento / der Werkssachverständigen / Works inspector / L' agent d' usine

M. Rizzotto *[Signature]*

Pagina - 2 di 2



MILL TEST CERTIFICATE



Basauri Plant

ISO 9001 - ISO/TS 16949

CUSTOMER: TERNINOX, SPA	WORKS REFERENCE: 1323295
REFERENCE: 114140	SALES ORDER: 189771-5
PRODUCT NR:	HEAT NUMBER: 41953
VERSION: 96655	ROLLED: 08.02.2008

REQUIRED PRODUCT			
AISI304/304L(1.4301/1.4307) IM ROUND BARS TURNED SOLUTION ANNEALING 50 +/-0.45 mm			
ISO k13 4.500/6.000 mm RANDOM			
EXPEDITION	DELIVERY: 80215102	WEIGHT (KG): 2.919	BUNDLES: 2
			UNITS: 32

MADE ACCORDING TO			
ASTM A276 - 2002 ; AD-M2 - 01.09.1998 ; AD-W10 - 01.11.1987 ; DIN 17440 - .09.1996			
ASTM A479-A479M - 2003 ; ASTM A182-A182M - 2007 ; EN 10088-3 - 01.04.1995			
ASME SA479-SA479M - 2004 ; ASME SA182-SA182M - 2001 ; NACE MR0175 2002 01.01.2002			
AISI STAINLESS STEELS - 01.03.1993 ; EN DIRECTIVA 97/23/CE:97 - 29.09.1997			
TERNINOX FICHA TECNICA ED1 1 29.10.2004 ; EN 10204 :2004 OCT. 2004 3.1			

CHEMICAL ANALYSIS OF HEAT									U: % HEAT NUMBER: 41953
	C	Mn	Si	P	S	Cr	Ni	N	
Min.						0,015	18,000	8,000	
Max.	0,030	2,000	0,750	0,045	0,030	19,500	10,000	0,1000	
Car.	0,024	1,690	0,350	0,033	0,027	18,350	8,130	0,0745	

MECHANICAL PROPERTIES AS SUPPLIED (CONDITIONS)
Specimen Test location: At 12,5 mm from the surface ; Temperature of: (1): Solution annealing 1.040 °C
Cooling: (1): Air

MECHANICAL PROPERTIES AS SUPPLIED (TEST)
Tensile test specimen direction (Longitudinal): Longitudinal
Tensile Strength (517/680 N/mm²): 613 N/mm²
Yield Strength(1) (Rp(0,2%)) >= 207 N/mm²; Rp(0,2%): 278 N/mm²
Yield Strength(2) ((1%)) >= 230 N/mm²; ((1%)) 321 N/mm² ; Elongation ((5d)) >= 45 %; ((5d)) 54,3 %
Reduction of Area (>= 50 %): 75,4 % ; Notch impact sample direction (Longitudinal): Longitudinal
Notch Impact sample type (ISO V): ISO V ; Notch Impact test Temperature (20 °C): 20 °C
K(1) (>= 100 J): 294 J ; K(2): 292 J ; K(3): 293 J ; Hardness (<= 215 HB): 194 HB

ADDITIONAL TESTS
Standard (ASTM E112-96- . . .1996) ; Grain size: Austenitic γ ; Standard (ASTM A262-01-2001)
Type / Method (Practice E) ; Intercrystalline Corrosion: OK.

NON DESTRUCTIVE TESTS
ULTRASONIC INSPECTION 100% ; O.K.

TUBO 2" SCH 160

TECHOMATIO S.p.A.
Quality Control
WITNESSED REVIEWED
Date: 27/06/10
Signature:

TECHNOLOGY & QUALITY CERTIFIES THAT THE PRODUCT FULL FILLS THE ORDER'S SPECIFICATIONS
APPROVED BY: MARCELINO GARCIA ZAYAS
DATE: 25.02.2008
REF.: 1001101320004
Page 1 of 1
SIGN:
Metallurgical Technical Analyst Level II

Acciaierie Valbruna S.p.A.



36100 VICENZA (Italia) - Viale della scienza, 25 z.l.
 Stab.: 36100 BOLZANO (Italia) - Via A. Volta, 4

Cliente / Abnehmer/Kunde
 TM TECNMATIC SPA
 VIA DELLE INDUSTRIE, 36
 25100-CREMONA-CR

Produttore: **STABILIMENTO DI BOLZANO**
 Hersteller/Werk/Produkt

Oggetto Prova: **Sottobilizzato Pelato**
 Prüfgegenstand/Prüfungsteil

Avviso di Spedizione: A-
 Lieferungsverhalten/Status

Ordine nr: **VS ORDINE 535-540**
 Bestell-Nr./auftrag/Bestellungsnummer

Tipo di Elaborazione: **E+AOD**
 Erzeugungsweg/Herstellung/Produktionsverfahren

CERTIFICATO DI COLLAUDO ABNAHMEPRUEFZEUGNIS INSPECTION CERTIFICATE CERTIFICAT DE RECEPTION EN 10204 3.1.B

Certificato nr: **MEST775434/2009**
 Prüfung/Zertifikat

Conferma ordine nr: **BS00001521**
 Werk/Dat./Order/Best.Nr.

Marchio di Fabbrica:
 Zeichen des Herstellers
 Trade mark
 Signe de l'usine productrice

Funzione del Collaudatore:
 Dienst/der Werkssachverständiger
 Inspector's stamp/Prüfungsteil/Inspekteur



Specifiche

Anforderungen/Requirements/Bedingungen

VAL STOCK 2004 1.4301/304 A
 ASME (1) SA182 2001 S30409 A 0
 ASME (1) SA479 2001 S30409 A 3
 ASTM A278 2000A S30409 A
 ASTM A484 2003A
 EN 10272 2000 1.4878A
 (0) SEC.II P.T.A 2001 EDITION
 (2) SEC.II P.T.A 2001 EDITION
 (4) Chemical analysis only and mech properties for ASTM A162(M)

AISI 304H
 ASME (1) SA193 2001 B8 CLASS 1
 ASTM A182 2002 S30409 4
 ASTM A320 2003 B8 CLASS 1
 DIN 17440 98 1.4878A
 NACE MR0175 2002 S30409

1SEC.II P.T.A 2001 EDITION
 3SEC.II P.T.A 2001 EDITION

AMS 5639 H S30409 A
 ASME (1) SA320 2001 B8 CLASS 1 (a)
 ASTM A193 2001A B8 CLASS 1
 ASTM A479 2001 S30409 A
 EN 10088-3 95 1.4301 A
 QQ-S-763 F 304 A

Qualità: **1.4878 MAXIVAL**

Werkstoff/Grade/Name

Marcia: **MVAIS/DE**

Markenbezeichnung/Brand/Name

Punzonatura: **1.4878**

Markierung/Marking/Urspage

Pos. nr. Pos. nr. St. de poste	Oggetto Description Design. de produit	Dimensioni - mm Abmessungen Dimension	Tolleranza Tolerance Tolérance	Lunghezza - mm Length Longueur	Colata Schmelze Coulée	Pezzi Stückzahl Pièces	Peso - KG Gewicht Poids	Lotto nr. Lose Lot n.
0010	Tondo	38,000	k12	5000 / 8000	9RN6		102,0	317800960

Sono state soddisfatte tutte le condizioni richieste
 Die gestellten Anforderungen sind, Anlage erfüllt
 The material has been furnished in accordance with the requirements
 Le matériel a été livré conforme aux exigences

Controllo antiradiazioni: OK
 Vorkontrollprüfung/strahlenschutz/Strahlungsprüfung
 Antineutron testing performed: OK
 Contrôle antiradiation: OK

Controllo visivo e dimensionale: soddisfa le esigenze
 Sichtprüfung und Ausmessung: sind Bestanden
 Visual inspection and dimensional check satisfactory
 Contrôle visuel et dimensionnel satisfaisant

TEST ALLO STATO DI FORNITURA											
Test on delivery condition Prüfung auf lieferbaren Produkt Test à l'état de livraison Prova sobre el material así como entregado											
TEST	Prova/Prüfung Beschreibung Long. Test Spec. Einf. Test Spec. Nied. Spec. Pressure Last. Spec. Sp. 1 mm	*C	Pos. Saglio Fughe Stitch q	Scorrevibilità Eigenschaften Vielbew. Stich-Fläche Rp 0,2% N/mm ²	Scorrevimento Eigenschaften Vielbew. Stich-Fläche Rp 1% N/mm ²	Resistenza Eigenschaften Tensile strength Tensile strength Rm N/mm ²	Allungamento Eigenschaften Elongation Elongation A5 E4d % %		Strizione Eigenschaften Reduction of area Reduction Z RA %	Resilienza Eigenschaften Impact Value Resilience KV J	Durezza Eigenschaften Hardness Hardness HB
Valori richiesti / Anforderungen/Bedingungen Vorschläge	min max			207 230	230 374	617 700	45 59	40	- 50	100	- 215
A	10.00	20	L	315	374	609	50	59	71	71	227 238 232 187

TEST	min	max
Dimensioni grano x ASTM E112		6

U=Ungedünnungs-, T=Invertierbohr-, G=Temperaturgeprüft

Analisi chimica

Chemische Zusammenlegung/Chemical Analysis/Analyse chimique

Colata/Abt./Coulée	Werk- max 0,075	1,00	2,00	15,00 15,00	1,00	1,00	0,00 10,00	0,00	0,00	0,100	-	-	-	-
	C %	Si %	Mn %	Cr %	Mo %	Cu %	Ni %	P %	S %	N %				
9RN6	0,047	0,71	1,69	18,05	0,41	0,43	8,55	0,024	0,023	0,002				

Corrosion test per EN ISO 3681-2A sensitized T1 : OK

Melted and manufactured in Italy No welding or weld repair Material free from Mercury contamination

We declare that the finished product is checked for radioactive contamination through Pedal System when it leaves the production plant,
 The Quality Management System is Certified acc. Pressure Equipment Directive (PED/SEC) Annex 1, 4, 5 by TÜV and Lloyd's

PRESA DI PRESSIONE
1/4" APT-F.

TECNOMATIC S.p.A.
 Quality Control
 WITNESSED REVIEWED
 Date: 27/04/10
 Signature: *[Signature]*

Bolzano, 31/07/09

880006
 (Mod. MCE0)

Il collaudatore di stabilimento / der Werkssachverständiger / Works Inspector / L'agent d'essai

M. Rizzotto

Pagina - 1 di 1



Tecno Saldo Pavese s.n.c.

CONTROLLI NON DISTRUTTIVI
 Loc. Fabbrica 27040 Arena Po (PV)
 Tel. 0385/263350 Fax 0385/272802
 Cod. Fisc./P.IVA: 00333080331

**RAPPORTINO RADIOGRAFICO
 RADIOGRAPHIC REPORT**

RR 1150/10

PAGINA **1** DI **1**
 PAGE **1** OF **1**

CLIENTE - CUSTOMER **TM-TECNOMATIC SPA** ORDINE - ORDER _____ COMMESSA - JOB _____

POS. - ITEM _____ MATERIALE - MATERIAL **AISI 304** CONDIZIONI SUPERFICIALI - SURFACE CONDITIONS **AS WELDED**

SPECIFICA GENERALE - GENERAL SPECIFICATION **ASME V ART.2 ASME VIII DIV.1 PAR.UW51** SPECIFICA CLIENTE - CUSTOMER SPECIFICATION _____ DISEGNO - DRAWING **N.**

OGGETTO - OBJECT **TUBO VENTURI ISO 5167 2° ANSI 2500** NOTE _____

Condizione dell'esame - examination conditions

TIPO SORGENTE SOURCE TYPE RX R k:150

NOME FABBRICANTE TRADE NAME **GILARDONI 300MHFD**

MACCHIA FOCALE FOCAL SPOT **1,5X1,5**

SPessore PENETRATED THICKNESS **9,5 mm.**

ENERGIA ENERGY **200 Kv.**

TEMPO ESPOSIZIONE EXPOSURE TIME **1'35" 6ma.**

DISTANZA FOCALE FOCAL DISTANCE **700 mm.**

PENETRAMENTO PENETRIMETER **ASTM 1A**

LATO FILM FILM SIDE LATO SORGENTE SOURCE SIDE

SPES. COMP. SHIM N.A. _____ TIPO FILM FILM TYPE **AGFA D4**

FILM SINGOLO SINGLE FILM FILM DOPPIO DOUBLE FILM

PARETE SINGOLA SINGLE WALL PARETE DOPPIA DOUBLE WALL

SCHEMO ANT. FRONT SCREEN **Ps** SPES. 0,10 mm THICK 0,10 mm

SCHEMO POST. BACK SCREEN **Ps** SPES. 0,15 mm THICK 0,15 mm

FORMATO PELLICOLA FILM SIZE **10X24**

SVILUPPO AUTOMATICO - DEVELOPMENT AUTOMATIC

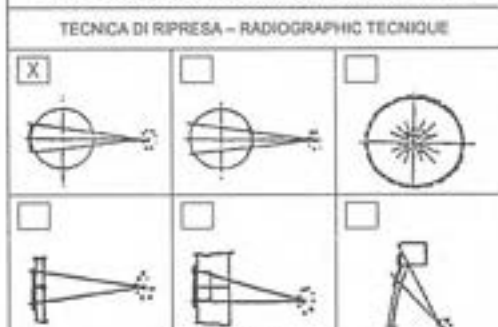

A INCLUSIONI GASSOSE GAS BUBBLES	L DIFETTO ALL'INCROCIO FAULT OF JUNCTION OF SEAM
B POROSITÀ POROSITY	M MANCANZA DI FUSIONE LACK OF FUSION
C TARI PIPES	N MANCANZA DI PENETRAZIONE INCOMPLETE PENETRATION
D INCLUSIONI DI SCORIA SLAG INCLUSIONS	O CRICCA CRACKS
E INCLUS. POLIGONALI INCLUSIONS OF ANY SHAPE	P CRICCA LONGITUDINALE LONGITUDINAL CRACKS
F INCLUS. ALLINEATE SLAG LINES	Q CRICCA TRASVERSALE TRANSVERSE CRACKS
G INCLUS. AD INTERVALLI WEAVING FAULTS	R INCISIONE UNDERCUTTING
H DIFETTO DI PALIZZA FAULT FROM BAD CHIPPING	S CORDONE IRRREGOLARE ERRATIC WELD BEAD
I DIFETTO DI RIPRESA FAULT FROM BAD PASS	

DATI RELATIVI AI FILMS - FILMS RESULTS

TRATTO POST. No.	RADIOGRAFIA N. RADIOGRAPHY No.	SALD. N. WELD No.	DENSITA' DENSITY	SIRE SENSIBILITY IMAGE QUALITY	DISCONTINUITA' DISCONTINUITY	DECISIONE DECISION
A	13883		1,8-4	0,33	/	OK
B	13883		1,8-4	0,33	/	OK
C	13883		1,8-4	0,33	/	OK
D	13883		1,8-4	0,33	/	OK
E	13883		1,8-4	0,33	/	OK
F	13883		1,8-4	0,33	/	OK
G	13883		1,8-4	0,33	/	OK
H	13883		1,8-4	0,33	/	OK
-----	-----	-----	-----	-----	-----	-----

CONFORME ALLA SPECIFICA CONF. TO SPECIFICATION NON CONFORME ALLA SPECIFICA NOT CONF. TO SPECIFICATION

NOTE - REMARKS _____ DATE - DATE **22/04/2010**

OPERATORE - OPERATOR _____

ISPIETTORE DEL CLIENTE CUSTOMER'S INSPECTOR _____

Tecno Saldo Pavese snc

QUALITY CONTROL

WITNESSED REVIEWED

27/2/2010

a) Si dichiara che il certificato riguarda solo i campioni sottoposti a prova. We declare that this report refers to the examined parts only.
 b) Si dichiara che il certificato non può essere riprodotto parzialmente, salvo nostra approvazione scritta. We declare that this report cannot be partially reproduced without our written approval.

LIQUID PENETRANT EXAMINATION (CONTROLLO CON LIQUIDI PENETRANTI)

DESCRIPTION (DESCRIZIONE)

Customer (Cliente)		Order No (Ordine N.)		TM JOB
S.I.E.T.		43-10		PT01/064-R10
Subject (Soggetto)			Plant (Impianto)	
No. 1 TUBO VENTURI 2" ANSI 2500 WN-LF/LM			/	
Doc. N.	Rev.	Step (Fase)	Drawing (Disegno)	Material Type (Tipo di Materiale)
/		/	064.R10.D01	AISI 304
General Specification (Specificazione Generale)		Examination Procedure (Procedura di Esame)		Surface Condition (Condizione Superficiale)
ASME V-VIII / ASTM E 165		TM PROC.01 REV. 0		COME SALDATO

CHEEK (ESAME)

Utilized Products (Prodotti Utilizzati)	Water Washable (Solubile in Acqua)		Post Emulsifiable (Post Emulsionabili)		Solvent Removable (Solubile in Solvente)	
	Visivo (Visible)	Fluorescent	Visivo (Visible)	Fluorescent	Visivo (Visible)	Fluorescent
Cleaner (Pulitore)	SOLVENT					
Penetrant Bath N (Penetrante Bagno N)	VP 30					
Emulsifier (Emulsionatore)	/					
Solvent (Solvente)	/					
(Rivelatore Developer)	D 70					
Trade Mark (Marca Fabbricante)	NDT					

Precleanin (Pre Pulizia)	BY BRUSCHING	Dryparts (Essiccazione)	NORMAL EVAP.
Penetrant Application (Applic.Penetr)	SPRAY	Minimum Penetrant Time (Tempo Penetr/Minim)	15 MINUTES
Penetrant Removal (Rimoz/Penetr)	BY WATER	Emulsification Application (Applic/Emulsific)	/
Developing Application (Applic/Svilupp)	SPRAY	Minimum Developing Time (Tempo Min/Svilupp)	7 MINUTES
Black Light Intensity (Lungh/Onda Luce)	/	Test Temperature (Temperatura di Prova)	18°C
Max Reading Time (Tempo Max Lettura)	30 MINUTES	Post-Cleaning (Pulizia dopo Controllo)	BY SOLVENT

SKETCH OF WORKPIECE AND DISCONTINUITY INDICATION (SCHIZZO DEL PEZZO E DISCONTINUITÀ)

	DISCONTINUITY
	NESSUNA INDICAZIONE

RESULT (RISULTATO)

<input checked="" type="checkbox"/> Conforming (Conforme)	<input type="checkbox"/> Not Conforming (Non Conforme)	<input type="checkbox"/> Repair (Riparare)	<input type="checkbox"/> Reject (Scarto)
Notes			
LIQUIDI PENETRANTI ESEGUITI SULLE SALDATURE D'ANGOLO			

Examination Performed by (Esame eseguito da)	Purchaser's Inspector (Ispettore Cliente)	Authorized Inspector (Ispettore Ente Autorizzato)
<p>TECNOMATIC S.p.A. LIVELLO / Level II EN - 473 (D. Mastarvesti)</p>		
Date (Data) 23/04/2010	Date (Data)	Date (Data)

tecnomatic® S.p.a
CREMONA - ITALY



Dichiarazione di Conformità
Declaration of Conformity
Declaration de Conformité

La Ditta **TM TECNOMATIC S.p.a**
The Company

Dichiara con la presente la conformità del Prodotto
Herewith declares conformity of the Product

TUBO VENTURI 2" ANSI 2500 WN-LF/LM

S/N 064-R10/1

DN 2" ANSI 2500 WN- LF/LM	PS 173 barg	P.T. 260 barg	T. 0 / +330°C
Fluido: ACQUA	Stato del fluido: LIQUIDO	Gruppo: 2	

In accordo alla Direttiva Europea
In accordance with EC Directive

97/23/CE

Categoria di rischio:
Category of

I

II

III

IV

ARTICOLO 3 COMMA 3

Procedura di valutazione utilizzata:
Conformity assesment procedure

Modulo H

Organismo Notificato:
Notified Organism

Società Consortile PASCAL a.r.l.
Via SCARSELLINI, 13
20161 MILANO

Numero accreditamento ON:
Number of Notified Organism

/

Cremona, 27/04/2010

TECNOMATIC S.p.A.
Il Direttore Generale
The General Manager

 **TM TECNOMATIC SpA**
26100 CREMONA - Via delle Industrie, 36
Tel. +39.0372.21574 Fax +39.0372.28318
Partita IVA 01316980190

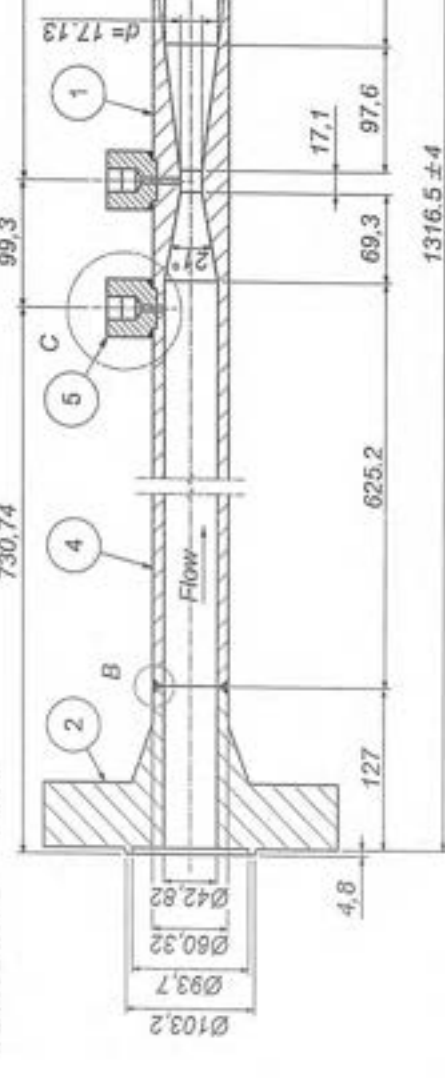
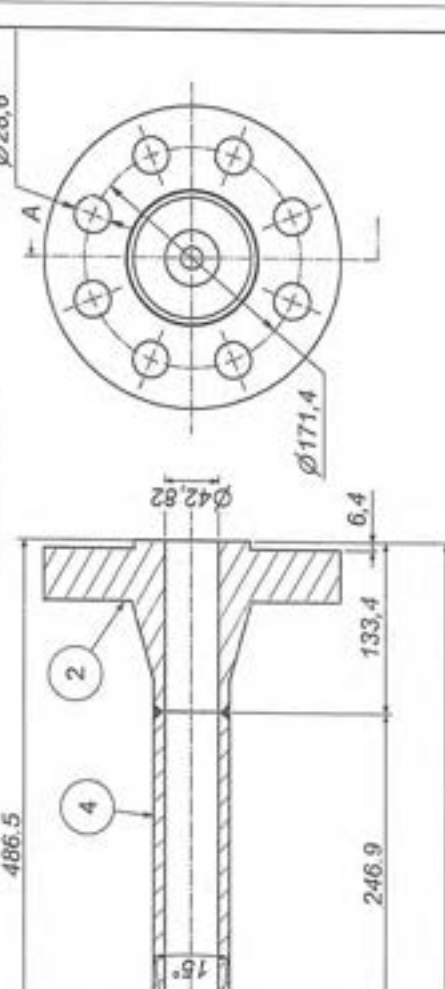
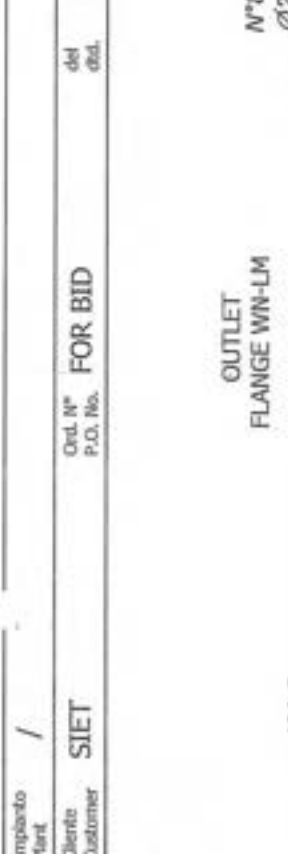

NAMEPLATE DETAIL

TECNOMAT SPA CREMONA - ITALY
 Product VENTURI TUBE - 1SD 5167
 SIGLA/TAG / /
 DIM/RATING 1 92" ANSI 2500 WN-LF
 PIPE INSIDE DIAMETER 142.82 mm
 THROAT DIAMETER 119.15 mm
 VENTURI MATERIAL 1A131 304
 THROAT MATERIAL 1A131 304
 FLANGES MATERIAL 1A131 304
 FLANGES MATERIAL 1A131 304
 FLOW DIRECTION

NOTES:
 -RX EXAMINATION ON CIRCUMFERENTIAL WELDS
 -PENETRANT TEST ON FILLET WELDS
 -HYDROSTATIC TEST AT 1,5 TIMES OF DESIGN PRESSURE
 (PED 97/23/CE Certification)

Code N° / Code No.	TV278QDB60013101		Scale Scale
	N/A - Default Peso / Materiale Weight / Material		Prodotto Production
	TUBO VENTURI SPECIALE DN 2" ANSI 2500 WN-LF / WN-LM		N° Part Qty 1
			Page Page 1 of 1
			Comments N° - Job No. 064-R10.100106
			N° Dis. - Draw No. 064-R10.D01
4			
3			
2			
1			
0			
1			

Item	Qty	Description	Material
5	1	PRESSURE TAPS ND 1/4" NPT-M 5.0000	1A131 304
4	2	PIECES OF PIPE ND 2" SCH. 160	1A131 304
3	1	FLANGE ND 2" ANSI 2500 WN-LM	1A131 304
2	1	FLANGE ND 2" ANSI 2500 WN-LF	1A131 304
1	1	BODY VENTURI	1A131 304



CREMONA
 ITALY

Allegato 14:

Documentazione valvola gate valve

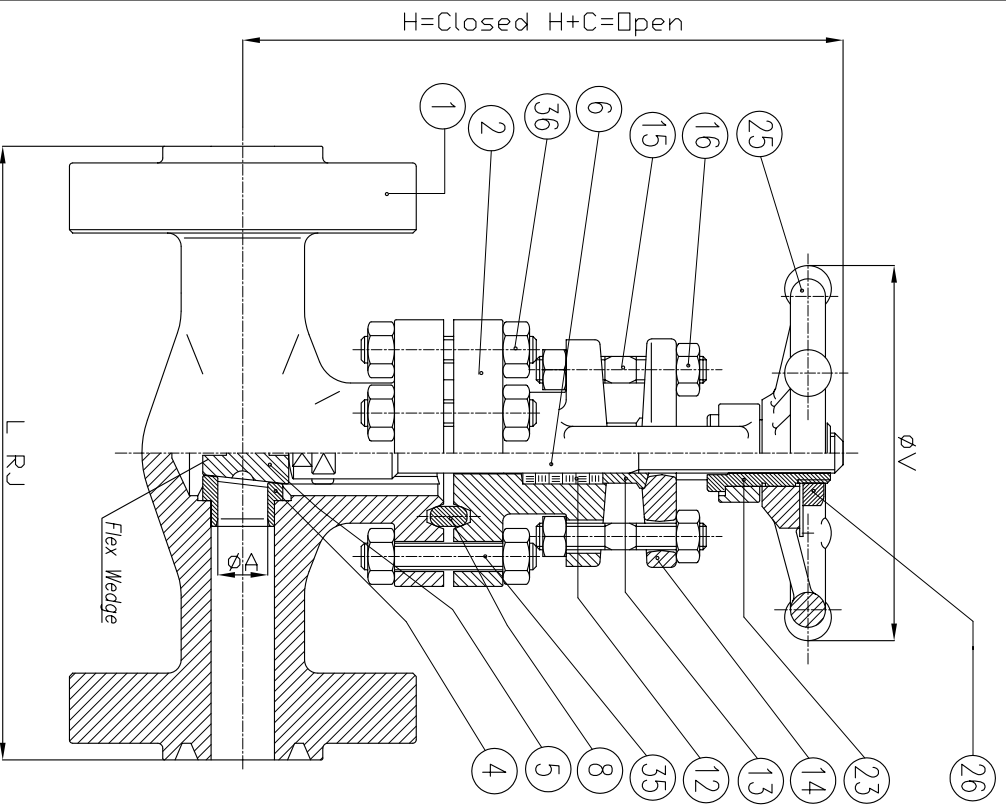

TAG	cust. item	VITAS item	Size	ϕA	C Travel	H+C	L	ϕV	Weight (kg)
-	-	-	1/2"	10	18	212	263.5	140	10
-	-	-	0.39"	0.39"	0.7"	8.35"	10.37"	5.5"	10
-	-	-	3/4"	14	19	256	273	175	16
-	-	-	0.55"	0.55"	0.75"	10.1"	10.75"	6.9"	16
-	-	-	1"	18	24	272	308	179	18
-	-	-	1" 1/2	31	37	411	387	250	40
-	-	-	1.22	1.22	1.45"	16.2"	15.25"	9.8"	40
-	-	-	36.5	44	422	454	350	350	57
1PN000DB902458	1	1	2"	1.44"	1.73"	16.6"	17.87"	13.8"	57

- 1 BODY
ASTM A 182 F316
- 2 BONNET
ASTM A 182 F316
- 4 SEAT
ASTM A 182 F316 + stellite
- 5 WEDGE
ASTM A 182 F316
- 6 STEM
ASTM A 182 F316
- 8 BONNET GASKET
RJ - ASTM A 182 F316
Graphite + braided graphite filled
- 12 PACKING
AISI 316
- 13 GLAND PACKING
ASTM A 182 F316
- 14 GLAND FLANGE
ASTM A 193 B8
- 15 GLAND BOLTS
ASTM A 194 Gr.8
- 16 BOLTS NUTS
AISI 416
- 23 YOKE BUSHING
CARBON STEEL
- 25 HANDWHEEL
CARBON STEEL
- 26 HANDWHEEL NUT
ASTM A 193 B8
- 35 BONNET STUD BOLTS
ASTM A 194 Gr.8
- 36 BONNET NUTS
ASTM A 194 Gr.8

Marking According to MSS SP-25
Design according to API 602
Ends to Ends according to ASME B16.10
Flange according to ANSI B 16.5



NUCLEAR & POWER DIVISION

CERTIFIED DRAWING		TYPE VALVE	FORGED GATE VALVE-B.B.-STD BORE-OSY	REV.	A
CUSTOMER:	SIET SPA	CLASS	2500	DATE	28/04/10
P.O. N°:	111-10	DWG. N°	1025R1146-V10-192	DRAW.	GS
PRJ:	-	FIG. N°	025R 100 RAM 1D	VER.	PZ
ITEM & TAG N°:	SEE ABOVE	VITAS REF.	V10-192	APPR.	SG

THIS DRAWING IS VITAS DIVISION OF VALVITALIA PROPERTY, REPRODUCTION IS STRICTLY PROHIBITED

Allegato 15:

Documentazione valvole e manifold

Instrument bulk material

e-mail: info@bulksrl.it

TEST & INSPECTION CERTIFICATE ACCORDING TO EN 10204 3.1		Certificate no: 10/A/261 Date: 16/04/2010		Page 1 of 1
Customer: S.I.E.T. SpA Via Nino Bixio, 27/C 29121 Piacenza	Pos.	Item/Description		Q.ty
	1	5 valves manifold P/N 5D1 (heat code E-09-24)		6
You P.O.: 103-10 Date: 01/04/2010				

Components	Material	CHEMICAL ANALYSIS									
		C%	Mn%	Si%	P%	S%	Cr%	Ni%	Mo%		
		MECHANICAL PROPERTIES									
Tensile N/mm ²	Yield stress N/mm ²	Elongation %	Area reduction %								
Body	ASTM 182 F316	0,066	1,580	0,550	0,028	0,012	16,200	10,090	2,170		
		599		397		52,80		74,2			
Gland body	ASTM A479 Gr 316	0,050	1,090	0,500	0,032	0,014	16,690	10,020	2,040		
Spindle	ASTM A479 Gr 316	0,020	1,750	0,530	0,025	0,021	16,150	10,090	2,110		

Visual & Dimensional checks: Satisfactory
Quantum of check: 100%

Valves pressure tested:

Hydrostatic			Pneumatic	Test results	
Body	Backseat	Seat		Hydrostatic	Pneumatic
Kg/cm ²	Kg/cm ²	Kg/cm ²	Kg/cm ²	positive	positive
620		420	6		

We certified that the reported chemicals and mechanical values of materials used for the above items are manufactured from materials purchased and certified in accordance with the purchase order requirements.

Third party inspection agency	Client inspector	Bulk
date	date	BULK s.r.l. date 16-04-2010

BULK srl

Instrument bulk material

via Giotto, 7 - 20032 Cormano - Milano - Italy

tel. +39 02.99.02.04.57 - fax +39 02.93.66.43.51

C.F. e P.IVA 12698060154 - Cap. Soc. EURO 30.000 i.v

Tribunale Milano n. Reg. Imprese 51594 - C.C.I.A.A. Milano n. REA 1579674

Instrument bulk material

e-mail: info@bulksrl.it

TEST & INSPECTION CERTIFICATE ACCORDING TO EN 10204 3.1		Certificate no: 10/A/261-1 Date: 16/04/2010		Page 1 of 1
Customer: S.I.E.T. SpA Via Nino Bixio, 27/C 29121 Piacenza	Pos.	Item/Description		Q.ty
	2	2 valves manifold P/N 2R7 (heat code E-09-63)		2
You P.O.: 103-10 Date: 01/04/2010				

Components	Material	CHEMICAL ANALYSIS									
		C%	Mn%	Si%	P%	S%	Cr%	Ni%	Mo%	Ti	Cu
		MECHANICAL PROPERTIES									
		Tensile N/mm ²	Yeild stress N/mm ²	Elongation %		Area reduction %					
Body	ASTM 182 F316	0,074	1,120	0,390	0,029	0,016	16,370	10,140	2,040		
		575		260		63,00		74,39			
Gland body	ASTM A479 Gr 316	0,045	1,260	0,680	0,022	0,021	17,510	12,050	2,130		
Spindle	ASTM A479 Gr 316	0,016	1,390	0,410	0,024	0,002	16,550	10,240	2,250		

Visual & Dimensional checks: Satisfactory
Quantum of check: 100%

Valves pressure tested:

Hydrostatic			Peumatic	Test results	
Body	Backseat	Seat		Hydrostatic	Pneumatic
Kg/cm ²	Kg/cm ²	Kg/cm ²	Kg/cm ²	positive	positive
620		420	6		

We certified that the reported chemicals and mechanical values of materials used for the above items are manufactured from materials purchased and certified in accordance with the purchase order requirements.

Third party inspection agency	Client inspector	Bulk
date	date	BULK s.r.l. date 16-04-2010

BULK srl

Instrument bulk material

via Giotto, 7 - 20032 Cormano - Milano - Italy

tel. +39 02.99.02.04.57 - fax +39 02.93.66.43.51

C.F. e P.IVA 12698060154 - Cap. Soc. EURO 30.000 i.v

Tribunale Milano n. Reg. Imprese 51594 - C.C.I.A.A. Milano n. REA 1579674

Instrument bulk material

e-mail: info@bulksrl.it

TEST & INSPECTION CERTIFICATE ACCORDING TO EN 10204 3.1		Certificate no: 10/A/261-2 Date: 16/04/2010		Page 1 of 1
Customer: S.I.E.T. SpA Via Nino Bixio, 27/C 29121 Piacenza	Pos.	Item/Description		Q.ty
	3	needle valves P/N 1VS8-SW-G (heat code E-09-63)		6
You P.O.: 103-10 Date: 01/04/2010				

Components	Material	CHEMICAL ANALYSIS									
		C%	Mn%	Si%	P%	S%	Cr%	Ni%	Mo%	Ti	Cu
		MECHANICAL PROPERTIES									
		Tensile N/mm ²	Yield stress N/mm ²	Elongation %	Area reduction %						
Body	ASTM 182 F316	0,045	1,270	0,480	0,045	0,027	16,030	10,220	2,030		
		582		266		64,12		75,32			
Gland body	ASTM A479 Gr 316	0,045	1,260	0,680	0,022	0,021	17,510	12,050	2,130		
Spindle	ASTM A479 Gr 316	0,016	1,390	0,410	0,024	0,002	16,550	10,240	2,250		

Visual & Dimensional checks: Satisfactory
Quantum of check: 100%

Valves pressure tested:

Hydrostatic		Pneumatic		Test results	
Body	Backseat	Seat		Hydrostatic	Pneumatic
Kg/cm ²	Kg/cm ²	Kg/cm ²	Kg/cm ²	positive	positive
620		420	6		

We certified that the reported chemicals and mechanical values of materials used for the above items are manufactured from materials purchased and certified in accordance with the purchase order requirements.

Third party inspection agency	Client inspector	Bulk
date	date	BULK s.r.l.  date 16-04-2010

BULK srl**Instrument bulk material**

via Giotto, 7 - 20032 Cormano - Milano - Italy

tel. +39 02.99.02.04.57 - fax +39 02.93.66.43.51

C.F. e P.IVA 12698060154 - Cap. Soc. EURO 30.000 i.v

Tribunale Milano n. Reg. Imprese 51594 - C.C.I.A.A. Milano n. REA 1579674

Allegato 16:

Documentazione valvole e manifold



**STRUMENTAZIONE
PER AUTOMAZIONE
E MISURE INDUSTRIALI**

SAMI INSTRUMENTS S.R.L.

Via Botte, 8 - Reschigliano di Campodarsego PD - Italy

Tel. ++39.049.920.1939 - ++39.049.920.1947

Fax ++39.049.921.7549

E-mail: quality@sami-instruments.com

"Direzione e coordinamento di gruppo: IVG S.P.A."

Spett./Messrs

SIET SPA

VIA NINO BIXIO, 27

29121 PIACENZA

ATTN. TEST DEPT.

Attn.

Fax n.

LETTERA DI TRASMISSIONE N. / Letter of transmission n.: 1000205-01-Reschigliano 06/04/10

ORDINE N. 82-10 DATA 23/02/2010 RIF. SAMI CO 1000205-01
Order Date Sami job

OGGETTO "DOCUMENTI FINALI"
Object

DOCUMENTO N. Document n.	EMISSIONE Issue	CODICE Code	Q.TA' DOCUMENTI Nr of copies	DESCRIZIONE Description
1000205-01	O	5	2 C	Certificate of compliance (ENG)
583349/2008	O	5	2 C	Test cert. AISI 316L: Bodies 5050 - 2150
326452/2006	O	5	2 C	Test cert. AISI 316L: Bodies 1000

C = copia / copy

R = riproducibile / radex copy

O = originale / original

CODICE DI TRASMISSIONE

Transmittal code

- | | |
|--------------------------------------|---|
| 1 Per informazione / For information | * 5 Finale / Final |
| 2 Per approvazione / For approval | 6 Appr. con commenti / Approved with comments |
| 3 Approvato / Approved | 7 Per costruzione / For construction |
| 4 Respinto / Rejected | 8 Per richiesta d'offerta / For inquiry |

PER CONOSCENZA

Copy to

//

A

B

NUMERO

Number

//

A = copia lettera di trasmissione / transmittal copy

B = documentazione completa / complete documents

PORGIAMO I NS. MIGLIORI SALUTI

Best regards

SAMI
Strumentazione per
Automazione e Misure Industriali

Firma / Signature



**STRUMENTAZIONE
PER AUTOMAZIONE
E MISURE INDUSTRIALI**

SAMI INSTRUMENTS S.R.L.

Via Botte, 8 - Reschigliano di Campodarsego PD - Italy

Tel. ++39.049.920.1939 - ++39.049.920.1947

Fax ++39.049.921.7549

E-mail: quality@sami-instruments.com

Direzione e coordinamento di gruppo: IVG S.P.A.

CERTIFICATO DI CONFORMITA'
Certificate of Compliance/Attestation de Conformité

TIPO DOCUMENTO Type Docum.	ANNO Year Année	N° ARCHIVIO File Number Archives numéro	fg. di fg. sh. of sh. Page de Page	ANNO Year Année	MESE Month Mois	GIORNO Day Jour
Q.C.	2010	1000205-01	1 1	2010	04	06

CLIENTE Customer Client	SIET SPA Piacenza	ORDINE N° P. Order N° Commande N°	82-10 dated 23/02/10
-------------------------------	----------------------	---	-------------------------

POS. Item	Q.TA' Q.ty Q.tè	DESCRIZIONE Description	MATRICOLA/TARGA Serial n. Repère
1	7	5050CDAHBBAA BAR-STOCK MANIFOLDS - S6000 FIVE VALVE - THREADED/FLANGED PROC./INSTR. CONN.: 1/2"NPT-F/STD FLG AT 180° DRAIN CONN.: 1/4"NPT-F C.W. PLUGS BODY MATERIAL: AISI 316L SEAL MATERIAL: PTFE	//
2	2	2150CDAHBBAA BAR-STOCK MANIFOLDS - S6000 TWOE VALVE - THREADED/FLANGED PROC./INSTR. CONN.: 1/2"NPT-F/STD FLG AT 180° DRAIN CONN.: 1/4"NPT-F C.W. PLUG BODY MATERIAL: AISI 316L SEAL MATERIAL: PTFE	//
3	6	1000CDADABBA BAR-STOCK VALVE - S6000 PROC./INSTR. CONN.: 1/2"NPT-F/F AT 180° BODY MATERIAL: AISI 316L SEAL MATERIAL: GRAPHOIL	//

CERTIFICHIAMO CHE LA FORNITURA E' STATA COLLAUDATA
ED E' CONFORME AGLI ACCORDI DI ACCETTAZIONE DELL'ORDINE.
WE HEREBY CERTIFY THAT MATERIAL DESCRIBED ABOVE HAS BEEN TESTED
AND COMPLIES WITH THE TERMS OF THE ORDER.
NOUS CERTIFIONS QUE LA LIVRAISON ETAIT VERIFIEE
ET EST CONFORME AUX STIPULATION DE L'ACCEPTATION DE LA COMMANDE

Firma

Strumentazioni per
Automazione e Misure Industriali

Acciaierie Valbruna S.p.A.



CERTIFICATO DI COLLAUDO
ABNAHMEPRUEFZEUGNIS
INSPECTION CERTIFICATE
CERTIFICAT DE RECEPTION
EN 10204 (2005) , 3.1

36100 VICENZA (Italia) - Viale della scienza, 25 z.l.
 Stab.: 39100 BOLZANO (Italia) - Via A. Volta, 4

Cliente / Bestell-/Purchase/Clien
SAMI INSTRUMENTS SRL
 VIA BOTTE, 8
 35011-RESCHIGLIANO-CAMPODARSEGO-PD

Avviso di Spedizione: A-VI08002512
 Uferverpack/Packing list/LL

Certificato nr: MEST583349/2008/
 PGIung/Test/Exam

Produttore: **ACCIAIERIE VALBRUNA S.P.A.**
 Hersteller/Werk/Usine producer

Ordine nr: N.01-700142
 Bestell/Your order/Commande

Conferma ordine nr: IT07001562
 Wuns/Ou Order/Rai n.

Marchio di Fabbrica:
 Zeichen des Lieferwerkes
 Trade mark
 Signe de l'usine productrice



Oggetto Prove: - Solubilizzato Trafilato
 Prüfgegenstand/Werk inspected/Finstage

Tipo di Elaborazione: E+A0D
 Erzeugungsart/Herfing process/Mode d'elaboration

Funzione del Collaudatore:
 Beispiel des Werkssachverständigen
 Inspector's stamp/Fonction de l'essayeur

Spedfiche:
 Anforderungen / Requirements / Exigences
SAMI 2004 S31603 A,Cf

ASTM A276 2006 S31603

Qualità: 316L
 Qualitäts/Grade/Qualité

Marca: APML
 Markenbezeichnung/Brand/Qualité

Funzionatura: 316L
 Kennzeichnung/Marking/Marquage

Pos. nr. Pos. nr. Item nr. Nr. de poste	Oggetto Gegenstand Product description Descr. de produit	Dimensioni - mm Abmessungen Dimension Dimension	Tolleranza Toleranz Allowance Tolerance	Lunghezza - mm Länge Length Longueur	Colata Schmelze Heat Coulée	Pezzi Stücke Pieces Pièces	Peso - KG Gewicht Weight Poids	Lotto nr. Lose Lot nr. Lot nr.
0010	Piatto	70,000 x 32,000	h11	3475 / 3670	244973		5468,0	708205150

Sono state soddisfatte tutte le condizioni richieste
 Die gestellten Anforderungen sind in Anlage erfüllt
 The material has been finished in accordance with the requirements
 Le matériel a été trouvé conforme aux exigences

Controllo antimiscelanza: OK
 Verwechslungsprüfung: spezialanalytisch durchgeführt
 Antilocking testing performed: OK
 Contrôle antimélange fait: s.s.

Controllo visivo e dimensionale: soddisfatti le esigenze:
 Sichtprüfung und Abmessung: ohne Beanstandung
 Visual inspection and dimensional check satisfactory
 Contrôle visuel et dimensionnel satisfaisant

TEST	Provetta/Prüfprobe Sonder-/Sonderprobe Leng. diam. spez. Stärke/Dicke, Dicke viele Stm. Thickness Leng. diam. spez. mm	Temperatura °C	Posiz. Saggio Prüfposition Position	Snervamento Streckgrenze Yield Stress Limite élastique Rp 0,2% N/mm2	Snervamento Streckgrenze Yield Stress Limite élastique	Resistenza Zugfestigkeit Tensile strength Résistance à traction Rm N/mm2	Allungamento Bruchdehnung Elongation Allongement E 4d %	Strizione Bruchdehnung Reduction of area Striction RA %	Resistenza Kerbschlagenergie Impact Value Resilience	Durezza Härte Hardness Dureté
Valori richiesti 1 Anforderungen/Requisit values Valeurs demandées		min max		170	-	485	- 30	- 40	-	-
A	12,5	20	L	431		673	48	69		

(L=longitudinale/longi, D=transversale/quer, T=Tangenziale/tangentiel)

Analisi chimica

Chemische Zusammensetzung/Chemical Analysis/Analyse chimique

1/1a Heat Stille/Coulée	min max	0,030	1,00	2,00	16,00 18,00	2,00 3,00	10,00 14,00	0,045	0,030	0,100	-	-	-	-	-
244973	C %	Si %	Mn %	Cr %	Mo %	Ni %	P %	S %	N %						
	0,017	0,46	1,38	16,97	2,04	10,12	0,029	0,028	0,073						

Melted and manufactured in Italy No welding or weld repair Material free from Mercury or radio-activity contamination
 The Quality Management System is Certified acc. Pressure Equipment Directive (97/23/EC) Annex 1, 3, 4.3 by TÜV and LLOYD'S

x Manifolds 5050 & 2150

**COPY CONFORMING
 TO THE ORIGINAL**
 S.A.M.I.

Vicenza, 28/01/08
 V00012
 (S.A.M.I. M.C.E.R.)

Il collaudatore di stabilimento / der Werkssachverständige / Works inspector / L'agent d'usine

M. Rizzotto

Pagina - 1 di 1

Acciaierie Valbruna S.p.A.



CERTIFICATO DI COLLAUDO
ABNAHMEPRUEFZEUGNIS
INSPECTION CERTIFICATE
CERTIFICAT DE RECEPTION
EN 10204 , 3.1

36100 VICENZA (Italia) - Viale della scienza, 25 z.i.

Stab.: 39100 BOLZANO (Italia) - Via A. Volta, 4

Cliente / Kund / Purchaser/Cliant
SAMI INSTRUMENTS SRL
 VIA BOTTE, 8
 35011-RESCHIGLIANO-CAMPODARSEGO-PD

Produttore: **ACCIAIERIE VALBRUNA S.P.A.**
 Hersteller/Usine producer

Avviso di Spedizione: A-VI06006337
 Gebührenschein/Freight Invoice

Ordine nr: ORDINE 500265 A
 Bestell/Your order/Commande

Certificato nr: MEST326452/2006/
 Prüfng/TierCert

Conferma ordine nr: IT05002500
 Werk/Dur Order/Nr.

Marchio di Fabbrica:
 Zeichen des Lieferanten/
 Trade mark
 Signe de l'usine productrice



Oggetto Prover: - Solubilizzato Trafilato
 Prüfgegenstand/Item inspected/Prozage

Tipo di Elaborazione: E+AOD
 Bearbeitungsart/Manufact process/Mode d'elaboration

Punzone del Collaudatore:
 Stempel des Werkstoffverständigen/
 Inspector's stamp/Plaqueon de l'essayeur



Specifiche:
 Anforderungen / Requirements / Exigences
SAMI 2004 S31603 A, CF

ASTM A276 2005A S31603

Qualità: 316L
 Material/Grade/Qualität

Marca: APML
 Markenbezeichnung/Brand/Qualität

Punzonatura: 316L
 Kennzeichnung/Marking/Markage

Pos. nr. Pos. nr. No. de poste	Oggetto Gegenstand Product description Description de produit	Dimensioni - mm Abmessungen Dimension Dimension	Tolleranza Toleranz Allowance Tolérance	Lunghezza - mm Länge Length Longueur	Colata Schmelze Melt Coulée	Peso Stückzahl Pieces Pièces	Peso - KG Gewicht Weight Poids	Lotto nr. Lose Lot nr. Lot nr.
0010	Quadro spigoli vivi	30,000 x 30,000	H11-MIN	3450 / 4000	241523	203	6315,0	514001870

Sono state soddisfatte tutte le condizioni richieste
 Die gesuchten Anforderungen sind erfüllt, Anlage erfüllt
 The specified has been furnished in accordance with the requirements
 Le matériel a été livré conforme aux exigences.

Controllo antimescolanza: OK
 Verwechslungsprüfung: spezialanalytisch durchgeführt
 Amalgam testing performed: OK
 Contrôle antimeslange fait: O.K.

Controllo visivo e dimensionale: soddisfatta le esigenze;
 Sichtprüfung und Ausmessung: alle Anforderungen
 Visual inspection and dimensional check/satisfactory
 Contrôle visuel et dimension: satisfait

TEST	Prove/Prüfung/ Essai/Exam/essai Lay. Dan. State Werk. Dan. Proben Lay. Dan. spez. item	°C	Snervamento Streckgrenze Yield Stress Limite élastique Rp 0,2% N/mm ²	Snervamento Streckgrenze Yield Stress Limite élastique	Resistenza Zugfestigkeit Tensile strength Résistance à traction Rm N/mm ²	Allungamento Streckdehnung Elongation Allongement E 4d %	Strizione Bruchdehnung Reduction of area Striction RA %	Resilienza Kerulungsenergie Impact Value Resilience	Durezza Härte Hardness Dureté
Valori richiesti 1 Anforderungen/Required values Valeurs demandées		min max	170	-	485	30	40		
A	12,5	20 L	482		688	47	69		

1) Lunghezza in filetti, G1/2" - 1/2" - 1/4" - 1/8" - 1/16"

Analisi chimica

Chemische Zusammensetzung/Chemical Analysis/Analyse chimique

Colata/Melt Schmelze/Coulée	min - max 0,050	1,00	2,00	16,00 - 18,00	2,00 - 3,00	10,00 - 14,00	0,045	0,030	0,100	-	-	-	-	-
	C %	Si %	Mn %	Cr %	Mo %	Ni %	P %	S %	N %					
241523	0,023	0,47	1,40	17,08	2,00	10,21	0,030	0,028	0,073					

Melted and manufactured in Italy No welding or weld repair Material free from Mercury or radio-activity contamination
 The Quality Management System is Certified acc. Pressure Equipment Directive (97/23/EC) Annex 1, A, A.3 by TÜV and LLOYD'S

x Values 1000

COPY CONFORMING
 TO THE ORIGINAL
 S.A.M.I.

Vicenza, 10/03/06
 Mod. VCO012

Il collaudatore di stabilimento / der Werkstoffverständiger / Work Inspector / L'agent d'usine

M. Rizzotto

Pagina - 1 di 1

Allegato 17:

Qualifica saldatore interno (WPQ)



CERTIFICATO DI QUALIFICA SALDATORE IN ACCORDO CON UNI EN 287-1:2007
WELDER APPROVAL TEST CERTIFICATE IN ACCORDANCE WITH UNI EN 287-1:2007

Certificato n° - Certificate No.: 0948 / MI / S / T-0611-2010

Designazione / Designation: UNI EN 287-1:2007 141/111 T BW 8.1 S/R t10(2,5/7,5) D80 H-L045 ss nb/mb

Procedura di riferimento del costruttore N° / Manufacturer's WPS reference N°: 0185

Nome del saldatore / Welder's name: FILELLA GIAMPIERO

Identificazione / Identification: FG

Metodo di identificazione / Method of identification: C.F. FLLGPR71M17F839A

Data e luogo di nascita / Date and place of birth: 17/08/1971 - NAPOLI (NA)

Datore di lavoro / Employer: SIET SPA - 29121 PIACENZA (PC)

Codice-Norma di riferimento / Code-Testing standard: UNI EN 287-1:2007

Conoscenze di lavoro / Job knowledge: Accettato / Acceptable Non provato / Not tested

Variabili / Variables	Dettagli Prova Pratica Weld Test Details	Campo di validità / Range of approval
Procedimento di saldatura / Welding process	141 / 111	141 / 111
Lamiera o tubo / Plate or pipe	Pipe	Plates and Pipes
Tipo di giunto / Joint type	BW	BW - FW
Gruppo(i) materiale(i) base Parent material group(s)	8.1	8 - 9.2 - 9.3 - 10
Metallo d'apporto: Tipo/Designazione Filler Metal: Type/Designation	S / R	S / A, RA, RB, RC, RR, R
Gas di protezione o Flusso / Shielding gas or Gas di protezione al rovescio / Backing gas	EN ISO 14175:03 (Ar 99,99%) EN ISO 14175:03 (Ar 99,99%)	-
Materiali ausiliari / Auxiliaries	N.A.	-
Spessore del materiale / Material Thickness [mm]	10	3 to 20
Spessore saldatura / Weld Thickness [mm]	2,5 / 7,5	2,5 to 5 / 3 to 15
Diametro esterno tubo / Pipe outside diameter	80	≥ 40
Posizioni di saldatura Welding position	H-L045	PA, PB, PC, PD, PE, PF, H-L045
Solcatura-Sostegno al rovescio Gouging-Backing	ss nb / mb	ss nb - ss mb - bs / ss mb - bs
Altri dettagli / Other	-	FW: sl, ml

Note - Remarks

Tipo di prova Type of test	Performed and acceptable	Osservazioni / Remarks
Visivo / Visual	yes	----
Radiografia Radiography	----	----
Magnetoscopia Magn. Particle Test	----	----
Liquidi Penetranti Penetrant Test	----	----
Macrografia Macro-section	----	----
Frattura / Fracture	yes	----
Piegamento / Bend	----	----
Prove aggiuntive Additional Tests*	----	----

*Allegare un foglio separato se necessario

*Append separate sheet if required

Prolungamento dell'approvazione da parte dell'Ente Esaminante Prolongation for approval by Examining Body		
Data / Date	Firma / Signature	Posizione-titolo/Position-title

Data di emissione / Date of issue: 22 February 2010

Luogo / Location: Casalecchio di Reno (BO)

Validità approvazione fino a / Validity of approval until: 21 February 2012

Ispettore / Inspector: Pecorari Giulino

Prolungamento per approvazione del costruttore / coordinatore di saldatura per i successivi 6 mesi
Prolongation for approval by employer / welding coordinator for the following 6 months

Data / Date	Firma / Signature	Posizione-titolo/Position-title

T.O.W. S.A.S.
 RUBIERA: Via MODENA, 8
 tel. 0522/629689
 fax. 0522/262105
 P.I.:00767890353

SPECIFICA DI SALDATURA
 Welding procedure specification (WPS) according to UNI EN ISO 15609-1 for welder qualification on

solo per qualifica saldatore

DITTA: SIET S.p.a.
 Via: NINO BIXIO ,27/C - 29121 PIACENZA (PC)
 P.Iva: 00817240336
 Sold: FILELLA GIAMPIERO N°Op: HN
 Nato a: NAPOLI (NA) il 17/08/1971
 C.F.: FLLGPR71M17F839A

SPEC. n° 0185 Data 22-2-2010
 W.P.S. Date
 WPQR No. Not Required
 Rif.Norma: UNI EN 287-1:2007
 Spec. Ref.
 C.Com.sa. C10020ARC

PROCESSO DI SALDATURA A: 141 Tig B: 111 ELETTRODO C:
 Welding process
 TIPO DI SALDATURA A: Manuale / Manual B: Manuale / Manual C:

TIPO DI GIUNTO E SEQUENZA DI SALDATURA
 JOINT DETAILS AND WELDING SEQUENCES

Tipo **BW Butt full penetration - Single V with root face and root gap** Giunto/Tubo/Trench, o tubo d'angolo /
 Joint type Branch connection angle
 Tipo di Supporto e metodo **No** Materiale di supporto e dimensione **N.A.**
 Method and type of backing Baking material and dimension

SCHIZZO schema

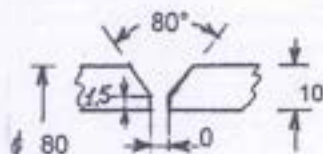

POSIZIONE DI SALDATURA
 WELDING POSITION

Posizione **H-L045 - Asse fisso inclinato 45°** Direzione di avanzamento **Ascendente - UP**
 position progressing welding

MATERIALE BASE
 BASE MATERIAL

Gruppo **B** Gr. **B** con Gr. **B**
 Norme e tipo: **ASTM A312 AISI 304L**
 Type and specification
 A. Norme e tipo: **ASTM A312 AISI 304L**
 Te type and specification
 Analisi chimica:
 Chemical analysis
 Gamma spessori (mm): **10**
 Thickness range
 Gamma diametri (mm): **80**
 Pipe diameter range
 Note:
 Other

PRERISCALDO E POSTRISCALDO
 PREHEAT AND MAINTENANCE

Temp. di preriscaldamento (C°): **EN ISO 13916 - Tp 20 CT**
 Preheat Temp
 Temp. di interpass (C°): **EN ISO 13916 - TI 200 CT**
 Interpass Temp.
 Temp. e tempo di preriscaldamento:
 Preheat maintenance temperature (C°) /

TRATTAMENTO TERMICO
 POSTWELD-HEAT TREATMENT

Temperatura	Tempo	Grad.riscald.	Grad.raffred.
temperature	time	heat rate	cool rate
/	/	/	/

MAT. D'APPORTO
 FILLER METAL

	A	B	C
Norma:	EN 12072	EN1600	
Spec. n°			
Tipo:	W 19 9 L	E 19 9 L R 1 2	
Type class			
Fabbricante:	ESAB	ESAB	
Manufacturer			
Design, Comm.:	OK Tigrod 16.10	OK 61.30	
F.M. Trade Name			
Dimensioni (mm):	2,4	2,5	
Size of filler metal			
Altro:	WELD METAL 2,5mm	7,6mm	
Other			

TECNICA DI SALDATURA
 WELDING TECHNIQUE

Tipo e Diam. dell'elettrodo, di W (mm): **EN ISO 6848 WT 20:ø2,4 mm**
 W electrode size type
 Diam. Ugello (mm): **10**
 Nozzle or gas cup size
 Metodo di preparazione e pulizia **Brushing and/or Grinding**
 Method of Preparation and Cleaning
 Metodo di ripresa al rovescio **NO**
 Method of back gouging
 Oscillazione ampiezza **N.A.**
 Oscillation amplitude Max width of run
 Oscillazione frequenza - sosta **N.A.**
 Oscillation frequency - dwell time
 Stick-out / Dist. ugello-pezzo **N.A.**
 Contact tube/inlet to work distance
 Passata singola o multipla **Multipass**
 Single or multiple electrodes
 File singolo o multiplo **String**
 Single or multiple electrodes
 Cordone stretto o oscillato
 String or weaves bead
 Angolo della torcia / Elettrodo /
 Torch / Electrode angle
 Dettagli per arco pulsato /
 Pulse welding details machine setting, program selection /

GAS di PROTEZIONE
 PROTECTION GAS

GAS	COMPOSIZIONE	PORTATA
Plasma welding details:	Mixture	Flow rate
Torcia: Shielding	*Ar 99,99	12-14
Aggiuntivo: Treading	/	
Rovescio: Backing	*Ar 99,99	2-4
Note:	*ISO 14178-1	

PARAMETRI ESECUTIVI

Passata	Proc. di saldatura	Tipo	Diam. mm	Welding data for GAS WELDING				Corrente	Velocità Filo	Volte	Vel. di saldatura	Apporto Termico	Note
				Heat input	Preheat	Shielding	Interpass						
1	141	W 19 9 L	2,4					DC EN	75-90	11-12			
2-n	111	E 19 9 L R 1 2	2,5					DC EP	60-70	22-24			

Firme di approvazione:
 Signature of approval



Note:
 DC=corrente continua EP=polarità inversa
 EN=polarità diretta N.A.=non applicabile
 Sh.A.=Short-arc Sp.A.=Spray-arc
 P.A.=Pulsed-arc

Costruttore Timbro e Firma
 Manufacturer Stamp and signature



Technology & Quality of Welding S.a.s.

Mod 0014
Rev. 0
03.01.2005

RESOCONTO DI PROVA

ESAME FRATTURA / FRACTURE TEST

Test report Rapporto di prova n°	C10020-4	Job Commessa	C10020
Date Data	11-03-2010	Place Luogo	Rubiera (RE)
Manufacturer Costruttore	SIET	WPS Procedura	185
Purpose of the examination Scopo dell'esame	Approval testing of welders	Plates or Pipes Lamiere o Tubi	See WPS
Parent Material Materiale base	See WPS	Welding Consumables Materiale d'apporto	See WPS
Heat Treatment Trattamenti termici	None	Test Temperature Temperatura di esecuzione del test	Room temperature

Reference standard Norme di riferimento	UNI EN 287-1:2007	Fracture Test Esame frattura	UNI EN 1320:1997
		Imperfection in metallic welds Imperfezioni nelle saldature metalliche	UNI EN ISO 6520-1:2001
		Quality level for imperfection Livello di qualità imperfezioni	UNI EN ISO 5817 (lev B)

UNI EN ISO 6520 - Classificazione Difettosità / Defects classification

100	Cricca Crack	300	Inclusione Solida Solid inclusion	5011	Inclusione marginale continua Continuous undercut	607	Sivellamento Linear misalignment	800	Altre imperfezioni Miscellaneous imperf.
104	Cricca di Cratere Crater Crack	301	Inclusione di scorie Slag inclusion	5013	Incisione al Vertice Shrinkage groove	609	Avvallamento Sagging	801	Colpo d'arco (sul pezzo) Stray arc
201	Soffiatura Gas cavity	304	Inclusione metallica Metallic inclusion (Cu,W, other)	502	Sovrametallo eccessivo Excess weld metal	610	Sfondamento Burn through	802	Spruzzo Spatter
2011	Poro Gas Pore	400	Mancanza fus. e pen. Lack of fusion and penetration	503	Concavità eccessiva Excess concavity	611	Riempimento incompleto, insellamento Incompletely filled groove	803	Strappo superficiale Tom surface
2012	Porosità unifor. Dtrib. Uniformly distrib. Pores	401 4011 4012 4013	Mancanza di fusione (incollatura) Lack of fusion (incomplete fusion)	504	Eccesso di penetrazione Excess of penetration	614	Superficie irregolare Irregular surface	804	Colpo di mole Grinding mark
2013	Nido di soffiature Clust. (localized) pores	402	Mancanza di penetrazione Lack of penetration	5041	Eccesso di penetrazione locale Local excess of penetration	615	Insellamento al vertice Root concavity	805	Colpo di scalpello Chipping mark
2016	Cavità allungata Elongated cavity	500	Forma difettosa Imperfect shape	505	Raccordo difettoso Incorrect weld toe	617	Ripresa difettosa Poor restart	806	Melatura eccessiva Underfusing
2018	Tarolo Worm-hole	601	Incisione marginale Undercut	506	Traboccamento Overlap			8021	Spruzzo tungsteno Tungsten spatter

Sample ID	Stamp	No. of splicement	Result		
			Type	Size of imperfection	Remarks
9	FG	Nr. 2 BW 60x10 Sr Fig. 9e	None	N.A.	Satisfactory
9	FG	Nr. 2 BW 60x10 Sr Fig. 9f	None	N.A.	Satisfactory

Examiner/Esaminatore		Certified by/Certificato da
Stamp and Signature Stamps e Firma		Name and Signature Nome e firma

T.Q.W. S.a.s. Technology & Quality of Welding

Via Modena 8- 42048 Rubiera (RE)

Tel. 0522-62.96.89 - Fax 0522-26.21.05

Internet: www.scuoladisaldatura.com • e-mail: info@scuoladisaldatura.com



GAS TECNICI INDUSTRIALI
GAS FRIGOTECNICI
IMPIANTI E PRODOTTI PER SALDATURA E TAGLIO
ASSISTENZA TECNICA
LABORATORIO DI SALDATURA

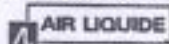

VALIDAZIONE DEI CERTIFICATI

Per rendere completa la certificazione è necessario:

- 1) Il timbro e la firma del Vostro responsabile in basso a destra sul modulo della WPS.
- 2) Il datore di lavoro oppure il coordinatore di saldatura (di norma appartenente all'azienda), deve firmare ogni sei mesi il certificato del saldatore nello spazio previsto, (Prolungamento per approvazione del costruttore / coordinatore di saldatura per i successivi 6 mesi) per documentare l'attività svolta ed attestare che le saldature eseguite sono della qualità richiesta.

ARCO GAS s.a.s.

ARCO GAS s.a.s. di Badovini Ernesto, Giancarlo, Cristian & C.

Via I. Pindemonte, 26/F - 29100 Piacenza - P.I. 00839170339 - Tel. 0523 613222 - Fax 0523 602265 - E-mail: info@arcogaspc.it

Allegato 18:

Qualifica saldatore esterno (WPQ)



NOME DEL SALDATORE : IVAN FAGIOLI
Welder's name

N° di matricola
Clock N°

N° Punzone F11
Stamp N°

Procedimenti usati GTAW + GMAW
Welding process(es) used

Tipo MANUAL
Type

WPS usata dal saldatore per eseguire il tallone di qualifica 09/09
Identification of WPS followed by welder during welding of test coupon N°

Materiale(i) base saldati ASTM A182 F304with the Same
Base material(s) welded

Spessore 13 mm
Thickness

Manual or Semiautomatic Variables For Each Process (QW-	ACTUAL VALUES	RANGE QUALIFIED
SUPPORTO (METALLO-FLUSSO ecc.) BACKING (METAL-FLUX etc.) (QW-402)	NONE	NONE
ASME P-No. CON ASME P-No. ASME P-No. TO ASME P-No. (QW-403)	8	P-No1 to 11 P-No34 P-No41 to 47
LAMIERA -TUBO (DIAMETRO ESTERNO) PLATE-PIPE (NOMINAL DIAMETER IF PIPE)	PIPE Ø 168.3 mm	FROM 2"7/8 NPS AND OVER AND PLATES
SPECIFICA MATERIALE D'APPORTO (SFA) FILLER METAL SPECIF. (SFA) (QW-404)	SFA 5.9 ER 308 (GTAW) SFA 5.9 - ER 308 (GMAW)	SFA 5.9 - EXX XX SFA 5.9 EX XX
MATERIALE D'APPORTO F-No. FILLER METAL F-No.	6	6
TIPO METALLO D'APPORTO PER GTAW PAW FILLER METAL VARIETY FOR GTAW PAW (QW 404)	N.A	N.A
INSERTO CONSUMABILE PER GTAW O PAW CONSUMABLE INSERT FOR GTAW OR PAW	N.A	N.A
DEPOSITO DI SALDATURA PER OGNI PROCEDIMENTO USATO WELD DEPOSIT THICKNESS FOR EACH WELDING PROCESS	3 mm (GTAW) 10 mm (GMAW)	Up to 1.5 mm Max to be welded
POSIZIONE DI SALDATURA WELDING POSITION (QW-405)	2G (GTAW) 2G (GMAW)	F, H F, H
PROGRESSIONE DI SALDATURA PROGRESSION (UPHILL / DOWNHILL)	N.A.	N.A.
SUPPORTO DI GAS PER GTAW , PAW O GMAW BACKING GAS FOR GTAW,PAW OR GMAW (QW-408)	NONE	NONE
GMAW CARATTERISTICA DELL'ARCO GMAW TRANSFER MODE (QW-409)		
GTAW CORRENTE DI SALDATURA / POLARITA' GTAW WELDING CURRENT TYPE / POLARITY	DC+ STRAIGHT	DC+ REVERSE

MACHINE WELDING VARIABLES FOR THE PROCESS USED (QW-360)	ACTUAL VALUES	RANGE QUALIFIED
DIRECT, REMOTE VISUAL CONTROL	None	None
AUTOMATIC VOLTAGE CONTROL (GTAW)	None	None
AUTOMATIC JOINT TRACKING	None	None
WELDING POSITION	None	None
CONSUMABLE INSERT	-	-
BACKING (METAL, WELD METAL, FLUX ETC)	-	-

GUIDED BEND TEST RESULTS

GUIDED BEND TESTS TYPE () QW-462.2 (SIDE) RESULTS () QW-462.3(A) (TRANS R&F)TYPE () QW-462.3(B) (LONG R&F) RESULTS

No 2 - QW 462.	SATISFACTORY	/	/
No 2 - QW 462.2	SATISFACTORY	/	/

RADIOGRAPHIC TEST RESULTS (QW-304 AND 305): SATISFACTORY

VISUAL EXAMINATION , SATISFACTORY

FILLET WELD : NA FRACTURE TEST : N.A.

LENGTH AND PERCENTAGE OF DEFECTS

MACRO TEST FUSION : NA FILLET LEG SIZE Inch. X inch.

CONCAVITY inch.
CONVEXITY inch.

WELDING TEST CONDUCTED BY: TECNO SALDO PAVESE

LABORATORY TEST No: MTC 1515/10

MECHANICAL TESTS CONDUCTED BY : TECNO SALDO PAVESE
IN LPM Snc

SOCIETA'
Organization



Allegato 19:

Controllo visivo saldature



Siet S.p.A.

CONTROLLO VISIVO

VT 001-10

Foglio 1 di 1

Commessa
1PN000DB90245Committente
ENEAAssuntore
SIET S.p.A.CIRCUITO PROVA BARRE
SIET S.p.A.- Piacenza

PCQ Rif.:

ITEM

TEST CODE

ESTENSIONE

100%

P&ID

074.01.00rev.3

Spec.Applicabile

UNI EN 13480-5:2003

STATO LAVORO

DOPO SALDATURA

OGGETTO:

Data Emissione Certificato

CONTROLLO VISIVO SULLE SALDATURE

E' STATO ESEGUITO IL CONTROLLO VISIVO SULLE SALDATURE

LINEE CONTROLLATE: DISEGNO SKETCH
074.00.00rev.3

ESITO: CONFORME

SIET S.p.A.

FIRMA

DATA

30/07/2010

Allegato 20:
Controllo dimensionale

Commissa 1PN000DB90245	Committente ENEA	Assuntore SIET S.p.A.	CIRCUITO PROVA BARRE	
PCQ Rif.	SISTEMA CIRCUITO PROVA BARRE	ESTENSIONE 100%	STATO LAVORO DOPO MONTAGGIO	
Disegno 074.00.00 rev.3	Spec.Applicabile DISEGNI	Strumenti utilizzati	FILO PIOMBO	

OGGETTO: CONTROLLO PLANARITA' - VERTICALITA' - ELEVAZIONI DELLA STRUTTURA DI SOSTEGNO CIRCUITO PROVA BARRE	Data Emissione Certificato
--	----------------------------

RISULTATO: CONFORME AL DISEGNO

SIET S.p.A.

FIRMA	DATA
	30/07/2010

Allegato 21:

Dichiarazione di conformità al progetto

DICHIARAZIONE DI CONFORMITÀ AL PROGETTO

Il Fabbricante: **SIET S.p.A.**
Via Nino Bixio, 27/c
29121 Piacenza, Italia

Dichiara sotto la propria responsabilità che l'impianto prototipo descritto in appresso:

Tipo: **Circuito prova barre**
Modello: **CPB**
Matricola: **001/2010**
Anno di costruzione: **2010**

è conforme alla Direttiva PED 97/23/CE, rientra nella classificazione PED "tubazioni" di classe di rischio I, opera con un fluido di gruppo 2 (acqua), ed è stato da lui progettato in conformità alla normativa europea armonizzata UNI EN 13480-3:2003. Il progetto è stato verificato ed approvato con verifica interna Siet S.p.A. in data 18/12/2009, ed il fabbricante può procedere alla realizzazione dell'impianto. Il progetto dell'impianto è dettagliatamente descritto nel documento SIET N. 01510ST09 emesso in data 18/12/2009.

Nella tabella a pagina successiva è riportato l'elenco dei disegni sulla base dei quali è stata confermata la validità del progetto.

Piacenza, 30 Luglio 2010

SIET S.p.A.

Il Rappresentante Legale

SIET Spa
Ing. Alfredo Luce
AMMINISTRATORE DELEGATO



RIFERIMENTO DISEGNI

074-00-00rev1:	Assieme generale
074-00-01rev1:	Dettagli (21 fogli)
074-00-02rev1:	Assieme inserito nella struttura (3 fogli)
074-01-00rev1:	Diagramma strumentato (2 fogli)
074-02-00rev1:	Schema di flusso

Allegato 22:

Dichiarazione di conformità alla fabbricazione ed installazione

DICHIARAZIONE DI CONFORMITÀ ALLA FABBRICAZIONE ED INSTALLAZIONE

Il Fabbricante: SIET S.p.A.
Via Nino Bixio, 27/c
29121 Piacenza, Italia

Dichiara sotto la propria responsabilità che l'impianto prototipo descritto in appresso:

Tipo: **Circuito prova barre**
Modello: **CPB**
Matricola: **001/2010**
Anno di costruzione: **2010**

è conforme alla Direttiva PED 97/23/CE ed è stato da lui costruito, controllato in tutte le fasi della fabbricazione, ispezionato (NDT), ed installato, in conformità alle normative europee armonizzate UNI EN 13480-1:5:2003.

Nella tabella a pagina successiva è riportato l'elenco delle norme armonizzate di riferimento utilizzate.

Il Fabbricante dichiara inoltre che l'impianto è stato realizzato, sotto la propria supervisione, seguendo una corretta prassi costruttiva.

Piacenza, 30 Luglio 2010

Il Fabbricante

SIET S.p.A.

Il Rappresentante Legale

SIET Spa
ing. Alfredo Luce
AMMINISTRATORE/DELEGATO



RIFERIMENTI NORMATIVI

NORMA	TITOLO DELLA NORMA
UNI EN 13480-1:5 -2003	"Tubazioni industriali metalliche"
UNI EN 10216:5	"Tubi senza saldatura di acciaio per impieghi a pressione – Condizioni tecniche di fornitura - Tubi di acciaio inossidabile"
ASME/ANSI B16.51996	"Pipe Flanges and Flanged Fittings"
EN 10222-5:2000	"Steel forgings for pressure purposes. Martensitic, austenitic and austenitic-ferritic stainless steels"
ANSI B36.19 - 1985	"Seamless and welded steel pipes"
ANSI B16.11 - 2005	"Threaded and socket welding fittings"
ANSI B36.34 – 1996	"Valves"
ASME/ANSI B16.9 – 1996:	"Wrought steel butt welding fittings"
EN 10028-7	"Flat products made of steels for pressure purposes. Stainless steels"

Allegato 23:

Dichiarazione di conformità alla prova idraulica

DICHIARAZIONE DI CONFORMITÀ ALLA PROVA IDRAULICA

Il Fabbricante: SIET S.p.A.
Via Nino Bixio, 27/c
29121 Piacenza, Italia

Dichiara sotto la propria responsabilità che l'impianto prototipo descritto in appresso:

Tipo: **Circuito prova barre**
Modello: **CPB**
Matricola: **001/2010**
Anno di costruzione: **2010**

è conforme alla Direttiva PED 97/23/CE ed ha superato la prova idraulica in conformità alle normativa europea armonizzata UNI EN 13480:5:2003. I risultati del test sono riportati nel certificato di prova idraulica, conservato, insieme a tutta la documentazione di progetto, negli archivi di SIET S.p.A. della sede di Piacenza.

Piacenza, 5 Agosto 2010

Il Fabbricante

SIET S.p.A.

Il Rappresentante Legale

SIET Spa
Ing. Alfredo Luce
AMMINISTRATORE DELEGATO



Allegato 24:

Certificato di prova idraulica



Siet S.p.A.

PROVA IDRAULICA/PNEUMATICA

PI 001-10

Foglio 1 di 3

Commissa 1PN000DB90245	Committente Enea	Assuntore SIET S.p.A.		Impianto/Localita' Siet S.p.A.- Piacenza
PCQ Rif.	P&ID 074.01.00rev.3	PCQ	FASE Commissioning	STATO LAVORO DOPO COMPLETAMENTO
LINEE INTERO CIRCUITO COME DA DISEGNO		Sketch 074.00.00rev.3	Spec.Applicabile UNI EN 13480-5:2003	
OGGETTO: PROVA IDRAULICA DI TENUTA SU CIRCUITO PROVA BARRE				Data Emissione Certificato

PRESSIONE DI PROGETTO 172.5 bar

PRESSIONE DI PROVA 246.7 bar

FLUIDO USATO ACQUA

TEMPERATURA FLUIDO 26.2 ÷ 26.4 ° C

IDENTIFICAZIONE MANOMETRO P1, S14728

CAMPO DI MISURA 0-300 Bar

TEMPO DI PROVA 2400 secondi

ESITO DEL CONTROLLO: CONFORME

NOTE:

SIET S.p.A.

FIRMA

DATA

05/08/2010

OGGETTO: PROVA IDRAULICA DI TENUTA SU CIRCUITO PROVA BARRE

MATERIALE IN ESAME/TEST MATERIAL

A312 TP304

FLUIDO DI PROVA/TEST FLUID

TEMPO DI PROVA/TEST TIME

PRESSIONE PROVA/TEST PRESSURE

ACQUA

2400 sec

246.7 bar

LINEE

Sketch

Spec.Applicabile

 INTERO CIRCUITO COME DA
DISEGNO

074.00.00rev.3

UNI EN 13480-5:2003

TABELLA RILEVAZIONE DATI DURANTE LA PROVA

n° Controlli	Data	Ora	Pressione Rilevata Mpa		Temperatura Rilevata, °C
1	05/08/2010	16.15.00	24.68		26.21
2	05/08/2010	16.20.00	24.75		26.25
3	05/08/2010	16.25.00	24.70		26.25
4	05/08/2010	16.30.00	24.73		26.28
5	05/08/2010	16.35.00	24.73		26.25
6	05/08/2010	16.40.00	24.73		26.29
7	05/08/2010	16.45.00	24.67		26.32
8	05/08/2010	16.50.00	24.74		26.33
9	05/08/2010	16.55.00	24.74		26.37

SALDATORE/WELDER

Allegato 17, Allegato 18

ESITO COLLAUDO/TEST RESULT

CONFORME

NOTE :

SCHEMA CON INDICATA LA POSIZIONE DEL MANOMETRO E DEL TERMOMETRO

SIET S.p.A.

FIRMA

DATA



05/08/2010

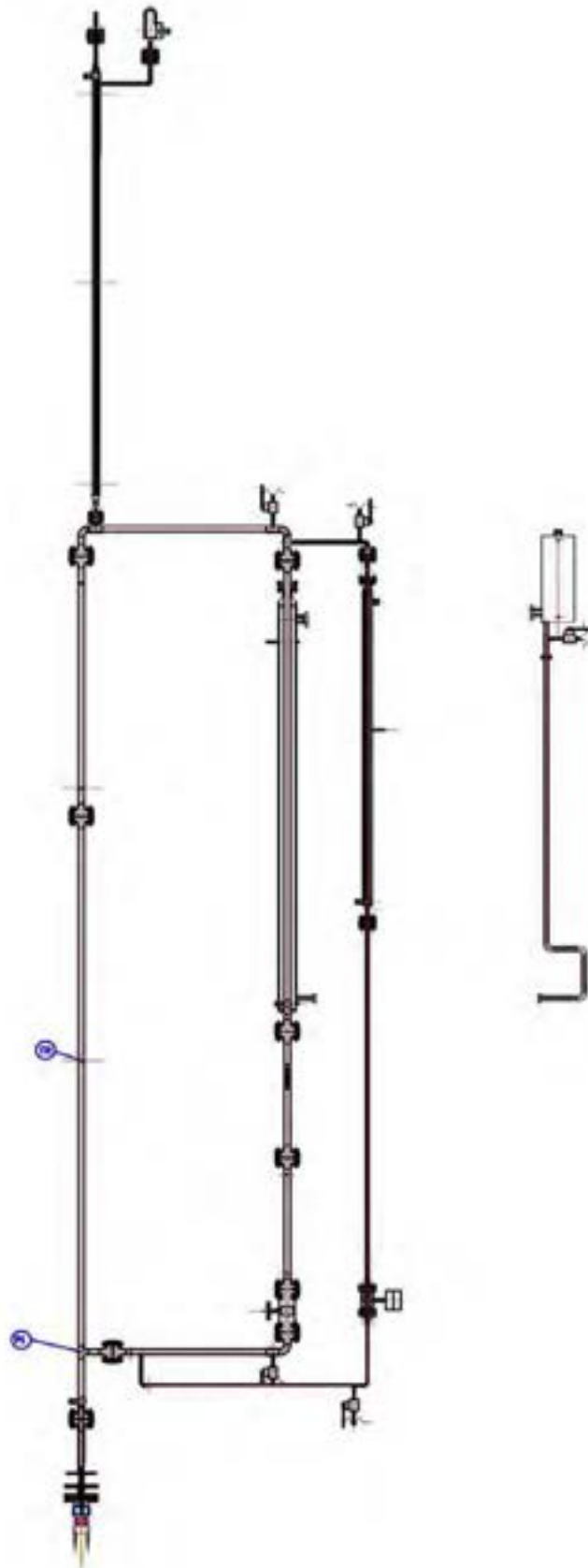

SIET S.p.A.

FIRMA

DATA

Adelmo Brusca

05/08/2010

Allegato 25:

Dichiarazione di conformità CE

DICHIARAZIONE DI CONFORMITÀ FINALE

Il Fabbricante: **SIET S.p.A.**
Via Nino Bixio, 27/c
29121 Piacenza, Italia

Dichiara sotto la propria responsabilità, avendone accertato:

- la soddisfazione di tutti i requisiti formali e materiali previsti dal modulo A della Direttiva PED 97/23/CE;
- la conformità al progetto;
- la corretta prassi costruttiva;
- la corretta installazione;
- il superamento di tutte le ispezioni e test previsti prima della messa in servizio dello stesso, ivi compresa la prova idraulica;
- la completezza della documentazione di progetto e certificazione, disponibile presso gli archivi della propria sede in Piacenza,

che l'impianto prototipo descritto in appresso:

Tipo: **Circuito prova barre**
Modello: **CPB**
Matricola: **001/2010**
Anno di costruzione: **2010**

è conforme alla Direttiva PED 97/23/CE ed alle normative europee armonizzate UNI EN 13480-1:5:2003 ed appone la marcatura CE nella targa di identificazione dell'impianto. Dichiara inoltre che l'impianto è destinato ad un uso esclusivamente interno, per l'esecuzione di prove di qualificazione componenti per conto terzi.

Piacenza, 5 Agosto 2010

SIET SpA

Il Rappresentante Legale

SIET Spa
Ing. Alfredo Lyce
AMMINISTRATORE DELEGATO



Allegato 26:

Specifica tecnica barre scaldanti primo fornitore



THERMOCOAX
from vision to reality

Offer 2H3.077.C.01.6.IT

Page 1/9

For the attention of :

R. Ferri, A. Achilli, S. Gandolfi,

Your contact:

Georges HELLEUX

Company: **SIET**

Dpt :

Tel. : [39] 0523623818 Std :

Tel.: + 33 (0) 1 41 38 80 53

Fax : [39] 0523623810

Fax : + 33 (0) 1 41 38 80 52

@ : gandolfi@siet.it

@ : georges.helleux@thermocoax.com

Please fax your order to the logistic department (+ 33 2 33 62 81 03) and mention the reference of this offer.

Subject : Budgetary offer for prototypical fuel pin simulator

Date : November 5, 2009

In blue bold typo, modifications compared to previous version.

Your document in reference: **Rod specifications revision 6**

Dear All

We are pleased to submit this budgetary offer for **Fuel Pin Simulator FPS** which describes the environmental conditions, scope of supply, technical parameters of the product and the organization of the project.

The FPS consists in active or inactive rods which by indirect electrical heating will reproduce the thermal condition of nuclear reactor fuel bundles.

The entire project will be organized to ensure repeatability of the solutions after testing.

w w w . t h e r m o c o a x . c o m

Sales office : 40 Bd Henri Sellier - F 92156 SURESNES Cedex

Tél.: +33 (0)1 41 38 80 50 - Fax :+33 (0)1 41 38 80 58 - @: info@thermocoax.com

Head office / Facility : Planquivon - F 61430 ATHIS DE L'ORNE

THERMOCOAX S.A.S. au capital de 457 500 € - RCS CONDE s/NOIREAU B 323 459 925 - N° TVA : CEE FR 32 323 459 92

THERMOCOAX

N° **EC2000R001**

Sce Commercial - Commercial Dept :
40 Bd Henri Sellier
✉ F 92156 SURESNES Cedex
Tél : +33 (0)1 41 38 80 50
Fax : +33 (0)1 41 38 80 70
http : //www.thermocoax.com

Siège Social - Head Office :
Planquignon - 61430 ATHIS DE L'ORNE -France
✉ BP 26 - F 61438 FLERS Cedex
Tél : +33 (0)2 33 62 81 00
Fax : +33 (0)2 33 62 81 09
e-mail : Planquignon@thermocoax.fr

THERMOCOAX S.A.S.
au capital de 457 500€
RCS CONDE SUR NOIREAU
B 323 459 925
N° Identification - VAT Nr :
CEE FR 32 323 459 925

Page : 1/17

Heating rods for fuel pin simulator

Diffusion :

Date :

Niveau : C

Thermal modeling

Documents annexes :

Référence THERMOCOAX
:OF : C01000868 SAQ
Code affaire : EC2000Client : **SIET**

Références :

« **Rod characteristics** »
rev.7 dated nov 6th 2009**DWG 074-00-01 rev.3**

T1002

Rév	Date	Dact.	Auteur	Ingénierie	Etudes	Assurance Qualité
1	16/07/ 10	XPO	XPO	X.POTIRON	D. LECHARPENTIER	P. GUILLON

Ce document propriété de la société
THERMOCOAX SAS ne peut être reproduit
ou communiqué sans autorisation écrite

T1002

Page de révisions

Code

EC2000R001

Rév.

1

Date

16/07/10

Auteur

XPO

Page

1A

THERMOCOAX

Ce document propriété de la société
 THERMOCOAX SAS ne peut être reproduit
 ou communiqué sans autorisation écrite

1. INTRODUCTION	3
2. CHARACTERISTICS OF THE ROD HEATERS	3
3. MODELING OF THE HEATER	6
4. THERMOPHYSICS PROPERTIES	6
5. PARAMETERS	6
5.1 Power	6
5.2 Environnement	7
6. STUDY AT FULL POWER	7
6.1 Results on the normal rod heater	7
6.2 Results on the hot rod heater	9
6.3 Conclusion	12
7. STUDY AT 20% POWER	12
7.1 Results on the normal rod heater	12
7.2 Results on the hot rod heater	14
7.3 Conclusion	17

T1002



Thermal modeling

<i>Code</i>		EC2000R001	<i>Rév.</i>	1
<i>Date</i>	<i>Auteur</i>	16/07/10	XPO	<i>Page</i>
				2/17

THERMOCOAX

1. INTRODUCTION

The aim of this study is to check the temperature along rod heater in several cases of study. Two types of rod heater are considered: normal rod and hot rod. For each type, the simulation will be performed with full power and with only 20% of the power as described in table 1 of the SIET specification.

2. CHARACTERISTICS OF THE ROD HEATERS

The power and the wall temperature are defined.

At full power, the following tables summarize the characteristics of a complete rod heater, which is constituted as described in the scheme below:

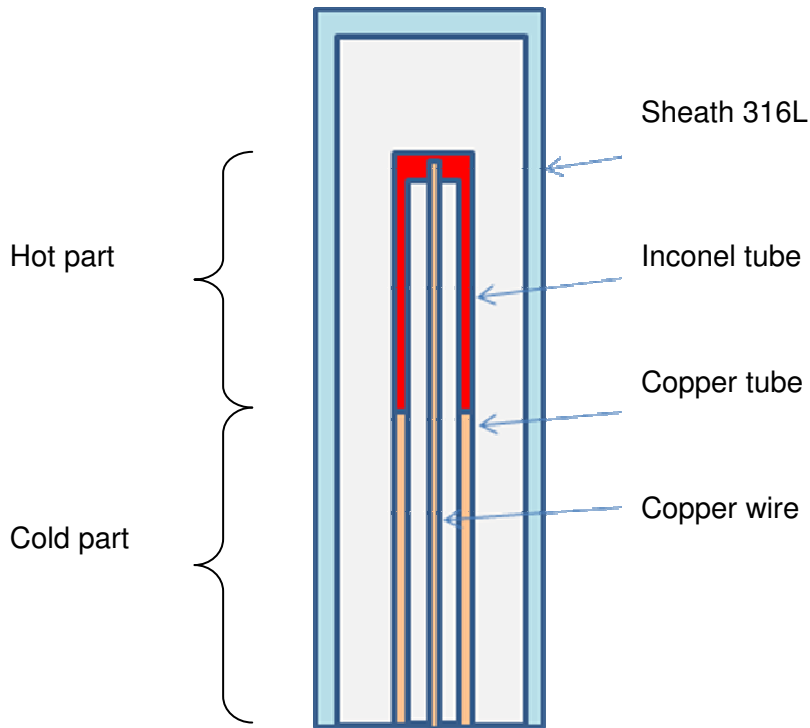

Thermal modeling

Code

EC2000R001

Rév.

1

Date

16/07/10

Auteur

XPO

Page

3/17

THERMOCOAX

T1002

Normal rod		
	Total power	28331 W
	Voltage	127 V
Hot part		
Inconel tube	Resistivity of Inconel	1,03E-06 Ω.m
	Length	4,191 m
	Intensity	223,08 A
	Resistance	0,541 Ohm
	Section	7,98 mm ²
	Power of inconel tube	26907,7 W
	∅ external of the tube	5,37 mm
	∅ internal of the tube	4,32 mm
Copper wire	Resistivity of copper	1,70E-08 Ω.m
	Length	4,191 m
	∅ wire	2,69 mm
	Resistance for 4,191m	0,013 Ohm
	Power of copper wire for 4,191m	625,5 W
	Total power of hot part	27533,1 W
Total length of central copper wire		7,183 m
Cold part		
Copper tube	Resistivity of copper	1,70E-08 Ω.m
	Length	2,992 m
	Section	7,98 mm ²
	Resistance	0,006 Ohm
	Power of copper tube	317,2 W
Copper wire	Resistivity of copper	1,70E-08 Ω.m
	Length	2,992 m
	∅ wire	2,69 mm
	Resistance for 2,992m	0,009 Ohm
	Power of copper wire for 2,992m	446,5 W
	Total power of cold part	763,7 W
Supply cable	Resistivity of copper	2,00E-08 Ω.m
	Length	1,2 m
	Section	35,00 mm ²
	Resistance	0,00068571 Ohm
	Power to dissipate	34,1 W

Table 1. Characteristics of normal rod heater

Thermal modeling

<i>Code</i>		EC2000R001	<i>Rév.</i>	1
<i>Date</i>	<i>Auteur</i>	16/07/10	XPO	<i>Page</i>
				4/17

THERMOCOAX

T1002

Hot rod		
	Total power	34071 W
	Voltage	127 V
Hot part		
Inconel tube	Resistivity of Inconel	1,03E-06 Ω.m
	Length	4,191 m
	Intensity	268,28 A
	Resistance	0,449 Ohm
	Section	9,37 mm ²
	Power of inconel tube	32334,7 W
	∅ external of the tube	5,88 mm
	∅ internal of the tube	4,75 mm
Copper wire	Resistivity of copper	1,70E-08 Ω.m
	Length	4,191 m
	∅ wire	2,94 mm
	Resistance for 4,191m	0,011 Ohm
	Power of copper wire for 4,191m	756,3 W
Total power of hot part		33091,0 W
Total length of central copper wire		7,183 m
Cold part		
Copper tube	Resistivity of copper	1,70E-08 Ω.m
	Length	2,992 m
	Section	9,37 mm ²
	Resistance	0,005 Ohm
	Power of copper tube	390,7 W
Copper wire	Resistivity of copper	1,70E-08 Ω.m
	Length	2,992 m
	∅ wire	2,94 mm
	Resistance for 2,992m	0,008 Ohm
	Power of copper wire for 2,992m	539,9 W
	Total power of cold part	930,6 W
Supply cable	Resistivity of copper	2,00E-08 Ω.m
	Length	1,2 m
	Section	35,00 mm ²
	Resistance	0,00068571 Ohm
	Power to dissipate	49,4 W

Table 2. Characteristics of hot rod heater

Thermal modeling

Code

EC2000R001

Rév.

1

Date

16/07/10

Auteur

XPO

Page

5/17

THERMOCOAX

3. MODELING OF THE HEATER

The modeling is limited to a section of the complete rod heater. This section includes 10cm of hot part and 10 cm of cold part.

4. THERMOPHYSICS PROPERTIES

The sheath is made of stainless steel 316L and the other parts are made of Inconel 600 or Copper. For the electrical insulant, we have the choice between MgO or BN which is more expensive but has a better thermal conductivity. The needed datas for the thermal modeling are:

- Density in kg.m^{-3}
- Heat capacity in $\text{J.kg}^{-1}\text{K}^{-1}$
- Thermal conductivity in $\text{W.m}^{-1}\text{K}^{-1}$

These values depend of the temperature. The thermal modeling takes it into account.

5. PARAMETERS

5.1 Power

The following powers are dissipated in the wire or in the tube:

Case 1 : full power

	Central copper wire	Copper tube (cold part)	Inconel tube (hot part)
Normal rod	149.2 W/m	97.9 W/m	6583.6 W/m
Hot rod	180.4 W/m	141.3 W/m	7901.4 W/m

Case 2 : 20% power

	Central copper wire	Copper tube (cold part)	Inconel tube (hot part)
Normal rod	29.8 W/m	19.6 W/m	1316.7 W/m
Hot rod	36.1 W/m	28.3 W/m	1580.3 W/m

Thermal modeling

Code

EC2000R001

Rév.

1

Date

16/07/10

Auteur

XPO

Page

6/17

THERMOCOAX

5.2 Environnement

The rod heaters are in contact with pressurized water.

The temperature of the wall is imposed for the study to the following values :

	Wall temperature at full power	Wall temperature at 20% power
Normal rod heater	450 °C	650 °C
Hot rod heater	500 °C	700 °C

Remark : In normal condition, under 155 bars, the temperature of water should be about 342 °C.

We made the hypothesis that the cooling system which shall protect the connectors will maintain the temperature of the wall at 60 °C.

6. STUDY AT FULL POWER

6.1 Results on the normal rod heater

For the cold part, with MgO insulant we obtain a maximum temperature of 494 °C on the central copper wire.

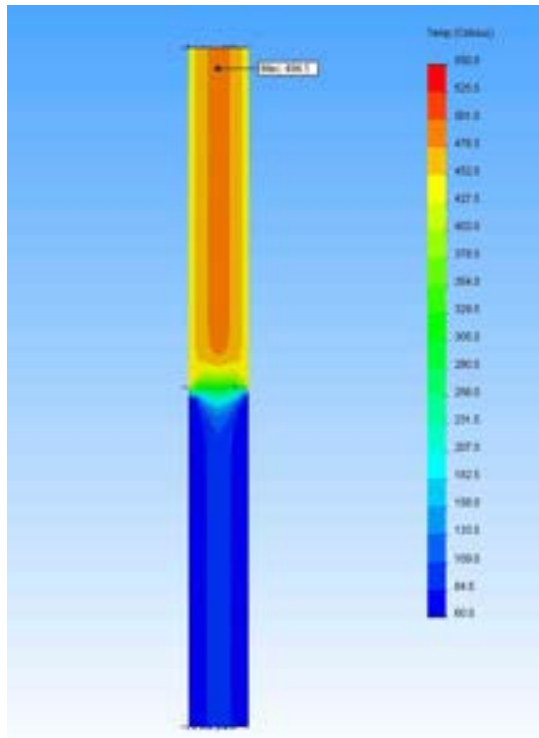

Temperature in cold part of normal rod, full power

T1002

Thermal modeling

Code

EC2000R001

Rév.

1

Date

16/07/10

Auteur

XPO

Page

7/17

THERMOCOAX

If we keep the same insulant for the hot part, the temperature reaches 983°C which is a little high for copper.

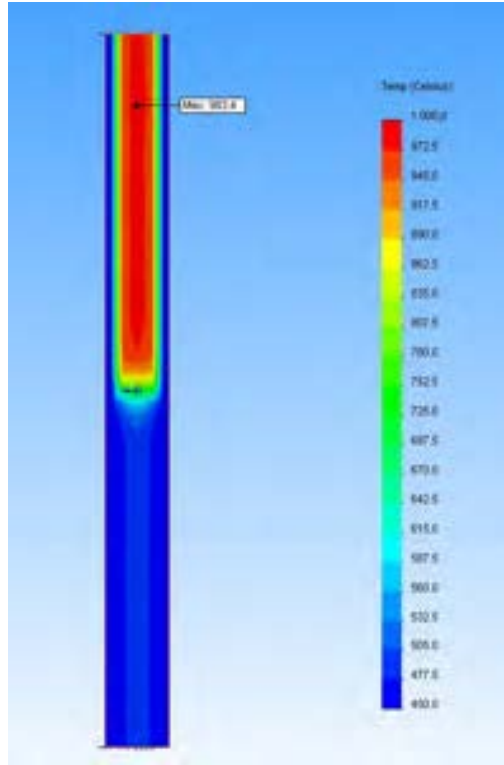

Temperature in hot part of normal rod, full power, MgO insulant

So we have to replace the MgO by BN insulant. In that case, because the thermal conductivity of BN is very good, the temperature reaches only 594°C which is acceptable.

T1002



Thermal modeling

<i>Code</i>	EC2000R001	<i>Rév.</i>	1
-------------	-------------------	-------------	----------

<i>Date</i>	16/07/10	<i>Auteur</i>	XPO	<i>Page</i>	8/17
-------------	-----------------	---------------	------------	-------------	-------------

THERMOCOAX

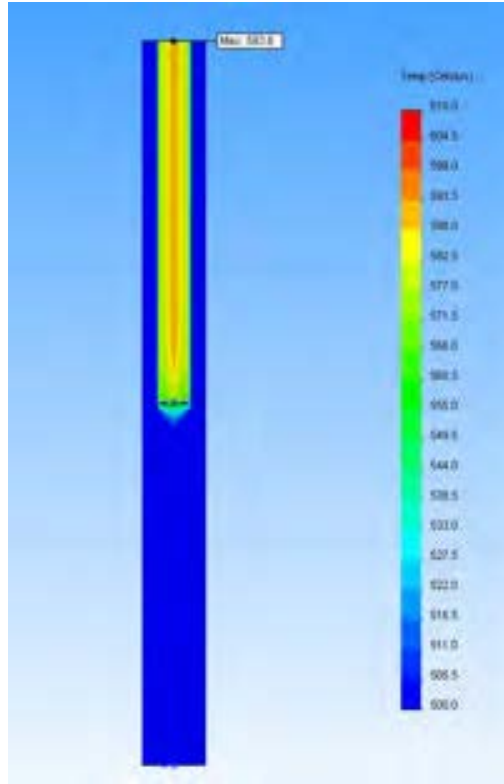

Temperature in hot part of normal rod, full power, BN insulant

6.2 Results on the hot rod heater

For the cold part, with MgO insulant we obtain a maximum temperature of 550°C on the central copper wire.

T1002



Thermal modeling

<i>Code</i>	EC2000R001	<i>Rév.</i>	1
-------------	-------------------	-------------	----------

<i>Date</i>	16/07/10	<i>Auteur</i>	XPO	<i>Page</i>	9/17
-------------	-----------------	---------------	------------	-------------	-------------

THERMOCOAX

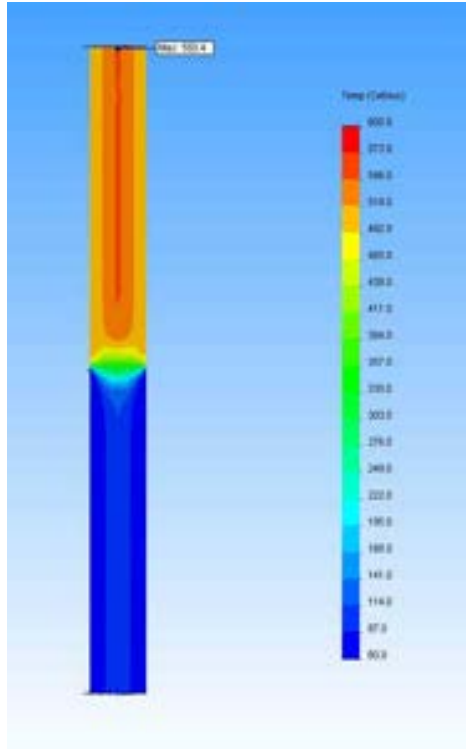

Temperature in cold part of hot rod, full power

If we keep the same insulant for the hot part, the temperature reaches 1023°C which is too high for copper (melting point of copper is 1084°C).

T1002



Thermal modeling

Code

EC2000R001

Rév.

1

Date

16/07/10

Auteur

XPO

Page

10/17

THERMOCOAX

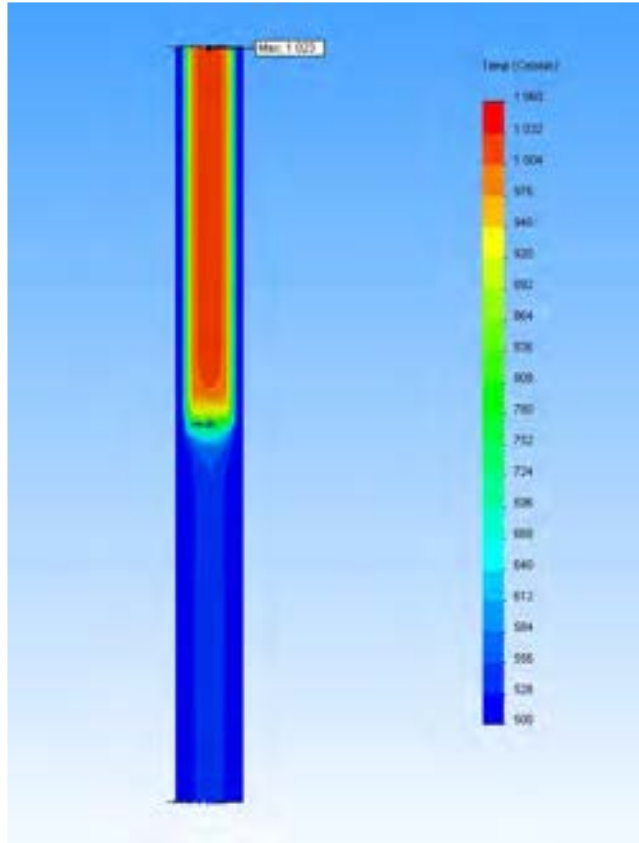

Temperature in hot part of hot rod, full power, MgO insulant

So we have to replace the MgO by BN insulant. In that case, because the thermal conductivity of BN is very good, the temperature reaches only 670°C which is acceptable.

T1002



Thermal modeling

<i>Code</i>		EC2000R001	<i>Rév.</i>	1
<i>Date</i>	<i>Auteur</i>	16/07/10	XPO	<i>Page</i>
				11/17

THERMOCOAX

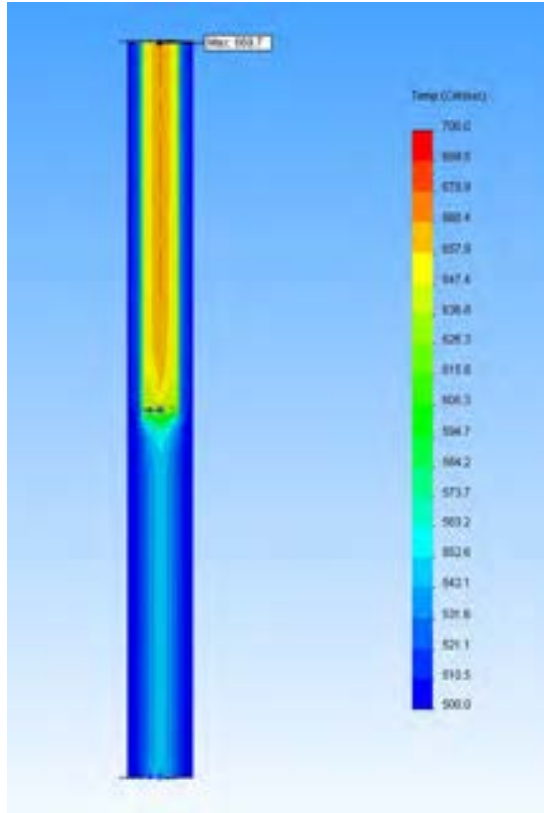

Temperature in hot part of hot rod, full power, BN insulant

6.3 Conclusion

The hot part of the normal rod heater should be manufactured with BN insulant in order to limit the temperature on the copper wire. The cold part will be manufactured with MgO insulant.

7. STUDY AT 20% POWER

7.1 Results on the normal rod heater

For the cold part, with MgO insulant we obtain a maximum temperature of 659°C on the central copper wire.

T1002



Thermal modeling

Code

EC2000R001

Rév.

1

Date

16/07/10

Auteur

XPO

Page

12/17

THERMOCOAX

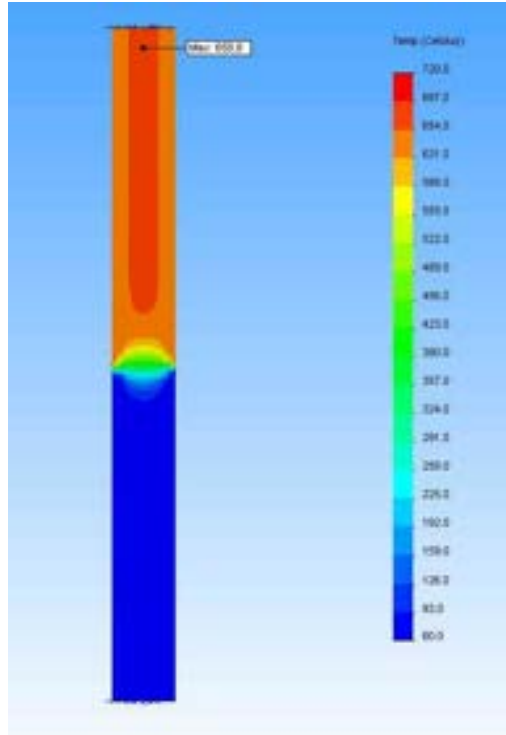

Temperature in cold part of normal rod, 20% power

If we keep the same insulant for the hot part, the temperature reaches 756°C which is a little high for copper.

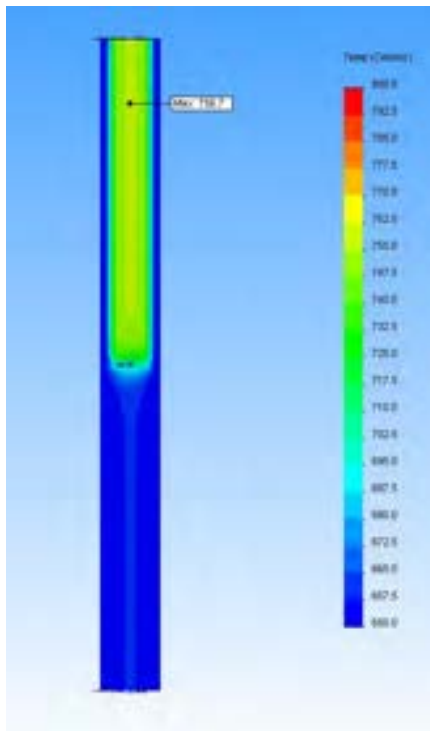

Temperature in hot part of normal rod, 20% power, MgO insulant

T1002



Thermal modeling

<i>Code</i>	EC2000R001	<i>Rév.</i>	1
-------------	-------------------	-------------	----------

<i>Date</i>	16/07/10	<i>Auteur</i>	XPO	<i>Page</i>	13/17
-------------	-----------------	---------------	------------	-------------	--------------

THERMOCOAX

So we have to replace the MgO by BN insulant. In that case, because the thermal conductivity of BN is very good, the temperature reaches only 679°C which is acceptable.

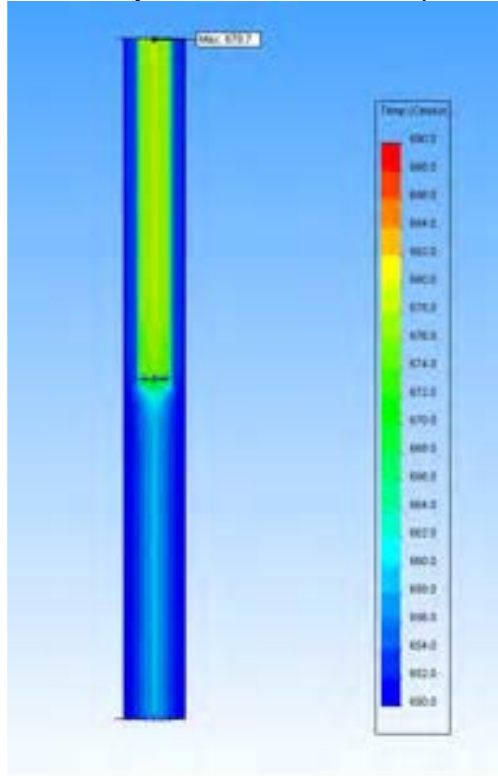

Temperature in hot part of normal rod, 20% power, BN insulant

7.2 Results on the hot rod heater

For the cold part, with MgO insulant we obtain a maximum temperature of 710°C on the central copper wire.

T1002



Thermal modeling

<i>Code</i>		EC2000R001	<i>Rév.</i>	1
<i>Date</i>	<i>Auteur</i>	16/07/10	XPO	<i>Page</i>
			14/17	

THERMOCOAX

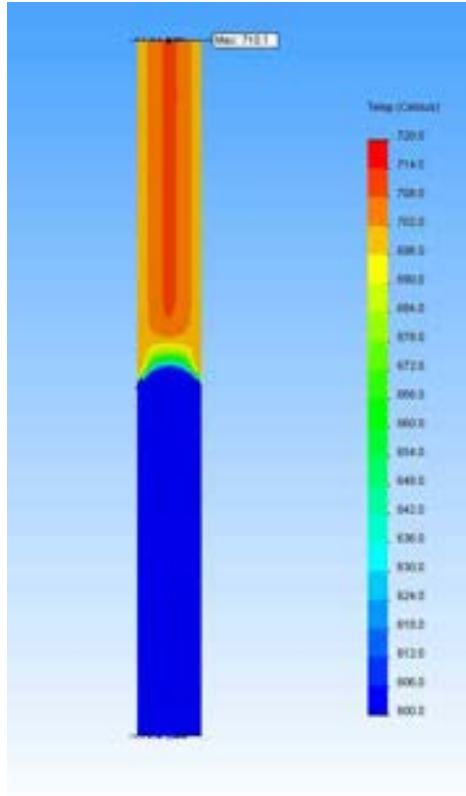

Temperature in cold part of hot rod, 20% power

If we keep the same insulant for the hot part, the temperature reaches 805°C which is high for copper (melting point of copper is 1084°C).

T1002



Thermal modeling

<i>Code</i>		EC2000R001	<i>Rév.</i>	1
<i>Date</i>	<i>Auteur</i>	16/07/10	XPO	<i>Page</i>
			15/17	

THERMOCOAX

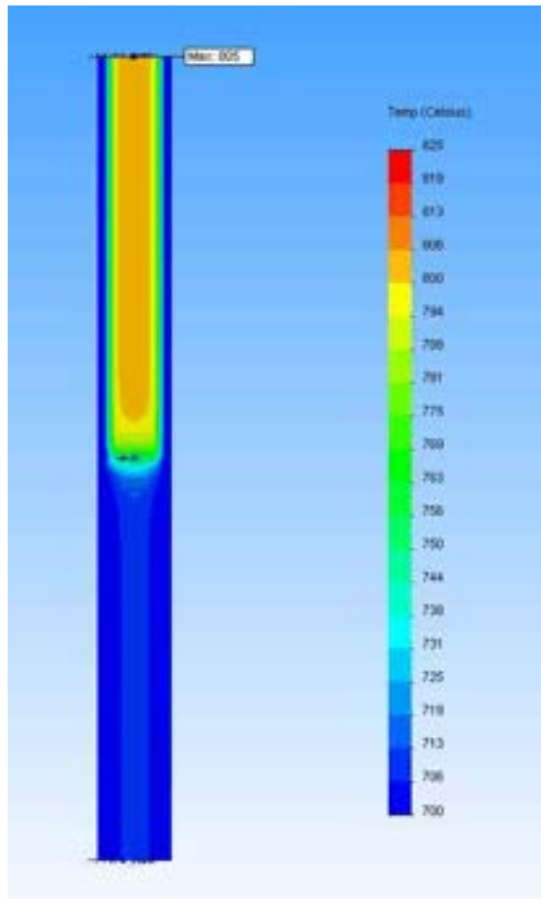

Temperature in hot part of hot rod, 20% power, MgO insulant

So we have to replace the MgO by BN insulant. In that case, because the thermal conductivity of BN is very good, the temperature reaches only 734°C which is acceptable.

T1002



Thermal modeling

<i>Code</i>		EC2000R001	<i>Rév.</i>	1
<i>Date</i>	<i>Auteur</i>	16/07/10	XPO	<i>Page</i>
				16/17

THERMOCOAX

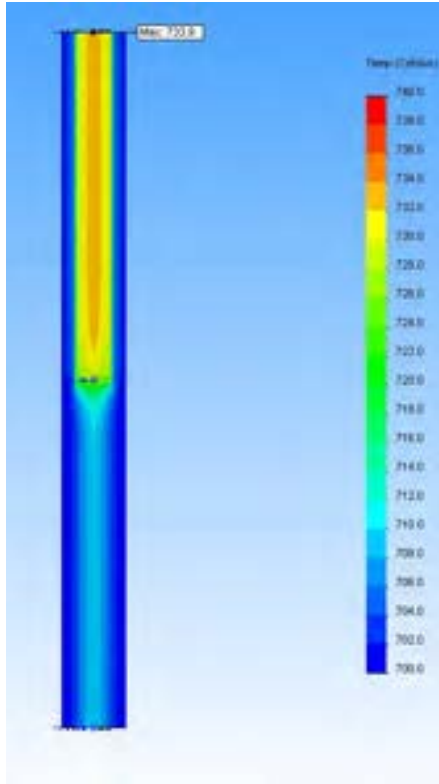

Temperature in hot part of hot rod, 20% power, BN insulant

7.3 Conclusion

The hot part of the normal rod heater should be manufactured with BN insulant in order to limit the temperature on the copper wire. The cold part will be manufactured with MgO insulant.

Because the temperature of the wall is higher in this cas, even if the power is lower, the temperature inside the rod heater will be approximately with the same level.

The using of BN insulant requires mounting care but it ensures a design in accordance with the requirement of SIET.

T1002



Thermal modeling

<i>Code</i>		EC2000R001	<i>Rév.</i>	1
<i>Date</i>	<i>Auteur</i>	16/07/10	XPO	<i>Page</i>
				17/17

THERMOCOAX

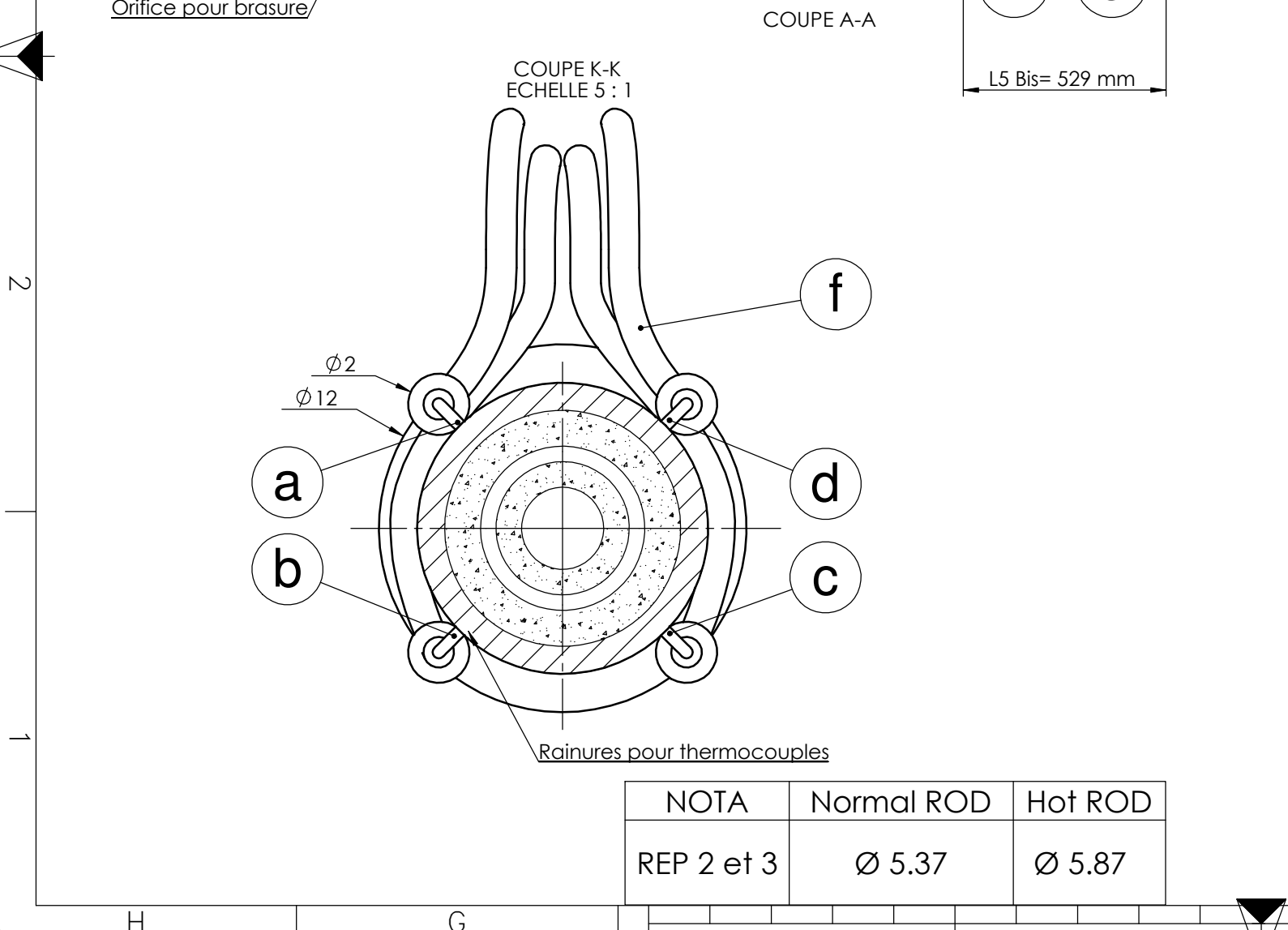
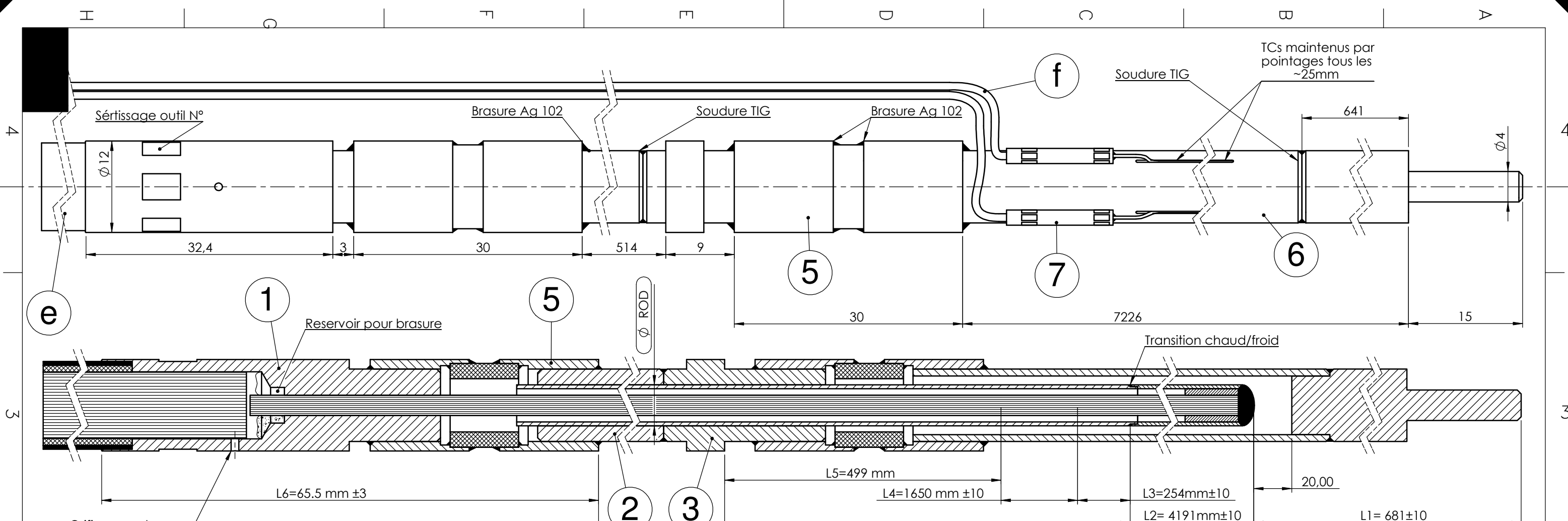

f	4	cable d'extension 2 AB 17 T.NN longueur 2m		
e	1	Cable d'alimentation type CSV-35mm ² lg 1m50 (OMERIN) (code 2110638)		
d	1	Thermocouple D lg suivant TUBE 1,2,3,4 (voir tableau sur plan 409 897) + 2m cable d'extension		
c	1	Thermocouple C lg suivant TUBE 1,2,3,4 (voir tableau sur plan 409 897) + 2m cable d'extension		
b	1	Thermocouple B lg suivant TUBE 1,2,3,4 (voir tableau sur plan 409 897) + 2m cable d'extension		
a	1	Thermocouple A lg suivant TUBE 3,4 (voir tableau sur plan 409 897) + 2m cable d'extension		
7	4	MCT 10	S-E 404 555	
6	1	CRAYON CHAUFFANT	S-E 303 263	
5	2	PASSAGE CERAMIQUE METAL	S-E 303 264	
4	1	CENTREUR	304 L 409 902	
3	1	BOUCHON	304 L 409 898	
2	1	TUBE INOX	304 L 409 896	
1	1	CONNECTION cuivre	Cu 409 895	
No. article	QTE	DESIGNATION	MATIERE	N° de PLANS

Tol. Gen.	± 2	Ra 3,2	SIET	Rev. A	Visa CVE
Matiere	-	ou Equiv	ENSEMBLE CRAYON CHAUFFANT		Etat initial
Traitement	-				
Ensemble	-				
Ce document propriété de la société THERMOCOAX SAS ne peut être reproduit ou communiqué sans autorisation écrite This document is the property of THERMOCOAX SAS and must not be reproduced and communicated without the written authorisation of THERMOCOAX SAS					
CODE	-	THERMOCOAX		PLANQUIVON	Niveau QUALITE
Dess. C.Vente	Verif	from vision to reality		F:61430 ATHIS DE L'ORNE	Q2
Date 27/04/10	Date			BP 26	
				F:61438 FLERS CEDEX	
T1006	DIFFUSION		Ech. 2:1	Format A3	303 262

NOTA	Normal ROD	Hot ROD
REP 2 et 3	Ø 5.37	Ø 5.87

1 Environmental conditions

The FPS assembly will have to simulate the thermal behavior of a bundle.

Some different mechanical parts will ensure the mechanical strength of the assembly and will guide the flow of water around the FPS (not in this scope of supply).

The heating rod in itself will consist in a sealed tube. This tube will be filled with mineral insulator. The selection of this mineral insulator will offer the best ratio for thermal conductivity and electrical insulation.

The heating will be due to the current in a resistance placed in the mineral insulator which will reproduce by electrical heating the high power density (or thermal flux) of fuel pins .

Each FPS will have an electrical connection on one side only.

The connection will be installed in a dead volume filled with a maximum temperature of 200° C.

The connection will have to endure the environment temperature plus the overheating due to electrical resistance in the connector plus the overheating due to conduction / convection.

The entire insulation volume where connection is located will be cooled by forced convection

Coolant in the area of the hot part of the rod will be pressurized water with at 360°C. Design will have to allow maximum working temperature **up to 700°C**

2 General description of the FPS

We see at the moment and based on our experience two construction options but a development only will let us know whether both are relevant.

A quantity of 233 normal rods are required plus 2 hot rods.

Type A

Basically type **A** would be based on a triaxial construction, the heater being a tube placed in between centered copper rod and external sheath .

Cross section of FPS
Copper wire in the center and
Inconel conductor. Outer
sheath made of SS 316 L.

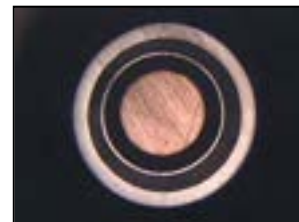

The heater is a thin tube made of Inconel or Stainless steel connected at the tip with the central copper wire. Due to its electrical resistance, the thin tube ensures the heat generation and current flows back to the same extremity trough the copper wire.

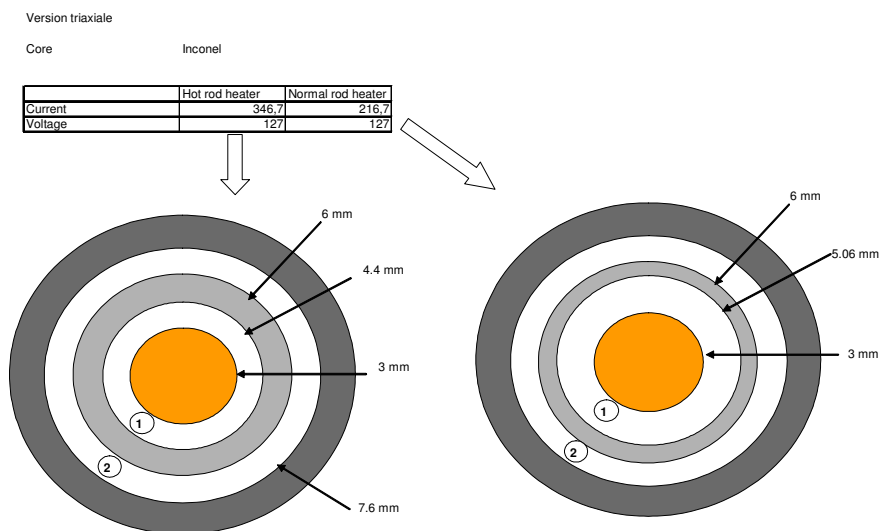

Type **B**

Type **B** will be based on a bifilar construction on the condition that voltage is increased.

This construction method brings less construction constraints as it is similar to thermocouple construction. Unfortunately geometrical parameters cannot allow the specified voltage.

An adequate voltage could be for instance 220 Volts which offers other significant advantage.

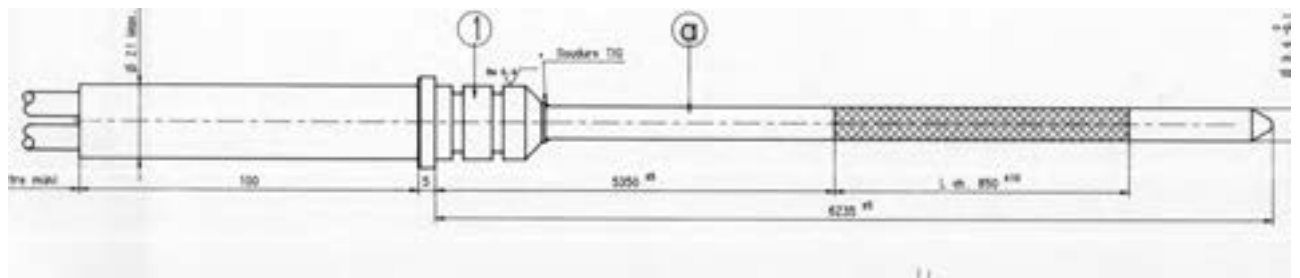

Thanks to the manufacturing methods used for our cold ends heaters transition hot / cold section can be located to the required positions. IN FPS case two wires will be used.

Geometrical parameters

Version bifilaire envisageable : exemples

	Hot rod heater	Normal rod heater
Current	200	125
Voltage	220	220

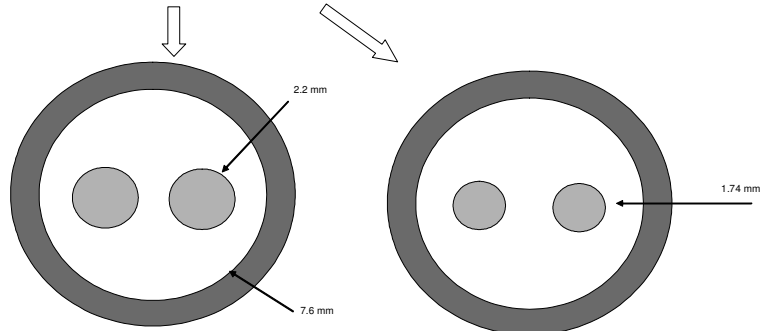

3 Scope of supply and Quality assurance follow up

All the project will be organize to ensure manufacturing repeatability of the solution. With the aim to structure the approach the following documents will be issued:

Phase 1

- Development quality plan.
 - Calculation of geometry of the heater
 - Thermal modelization
 - Construction steps of the samples
- General drawing of rod.
- Data sheet.
- Manufacturing of normal and hot rod type with 4 TC
- Test at high flux and control test procedure.

Prototypical pins tested at Thermocoax at low temperature and to SIET in normal operating conditions.

Phase 2

- Manufacturing quality plan
- Detailed drawings of FPS
- Manufacturing of normal and hot rod type
- Test at high flux in water of each rod before assembly and control test procedure

All documents quality plan will have to be reviewed by SIET (usually one week is allocated for that in our time frame)

SIET is entitled to come in THERMOCOAX factory for design review and at the end of each phase to attend and check our results.

A quantity of 233 normal rods and 2 hot rods are forecasted.

Not included: SIET is not entitled to be involved in the manufacturing process. Thermocoax will not be involved in the assembly of FPS and the dead volume (can be discussed later).

4 Technical parameters

After a preliminary technical study (to be confirmed in the design review of the qualification phase), the dimensional and electrical parameters offering the best construction will be defined based on the following parameters. Prototypical pins will have 4 TC on the surface. A mock up will be constructed to confirm feasibility for TC inside the pin. :

- :

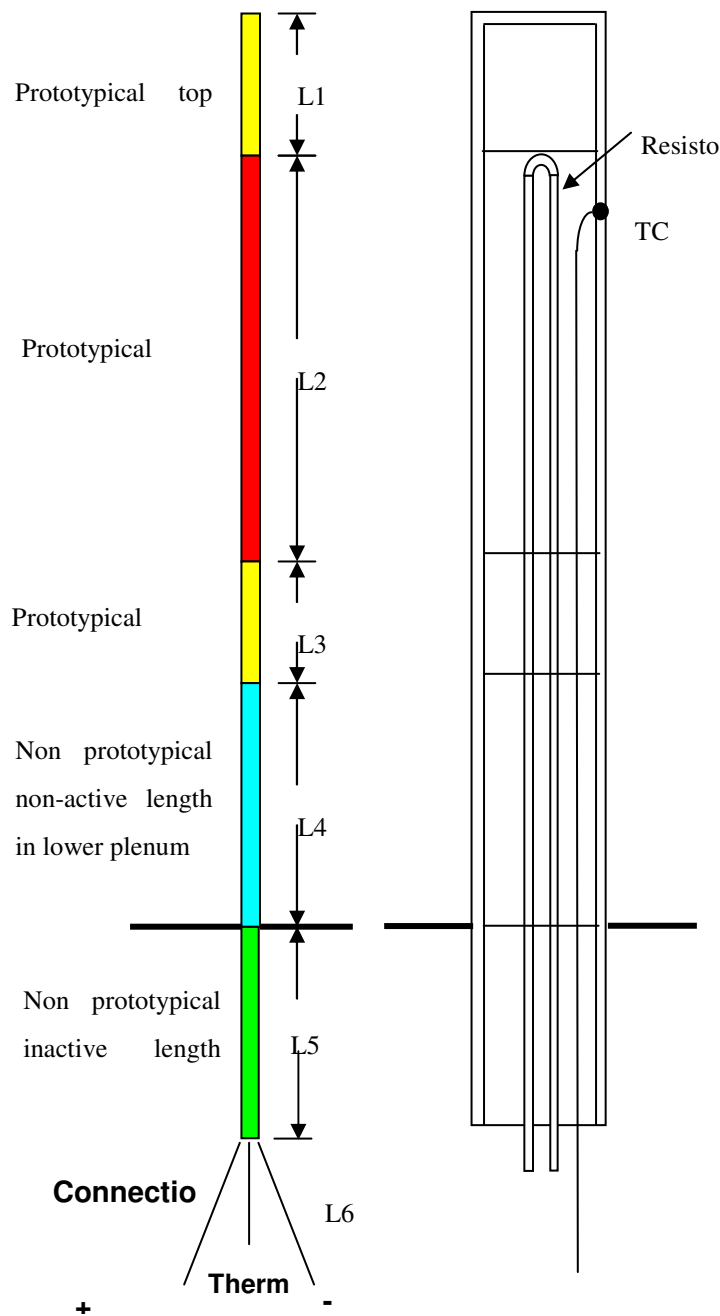

Electrical parameters (for information only, to be confirm later)

Type **A**

		Normal rod	Hot rod
Voltage	U (V)	127 V	127 V
Current	I(A)	216 A	261 A
Total heating power	P(W)	27 500	33 100

Transient with voltage increase from 127 V to 144 V

Type **B**

Voltage	U (V)	220V
Current	I(A)	125 A
Total heating power	P(W)	27 500



- Sheath will be electrically isolated from the conductors thanks to mineral insulator (MgO and /or Boron nitride).
- Instrumentation (usually type K thermocouple with OD 0.5 mm) can be inserted in the outer sheath of the FPS.
- **We will design a specific connector but some more space is required. In order to avoid any contact between connector we can slightly bend the FPS after the so that pitch is more than 12.5 mm AND we can put connectors at different elevation (define by L5 in your spec) by having short cold length on the FPS placed on the outer diameter and long length in the inner diameter.**

Allegato 27:

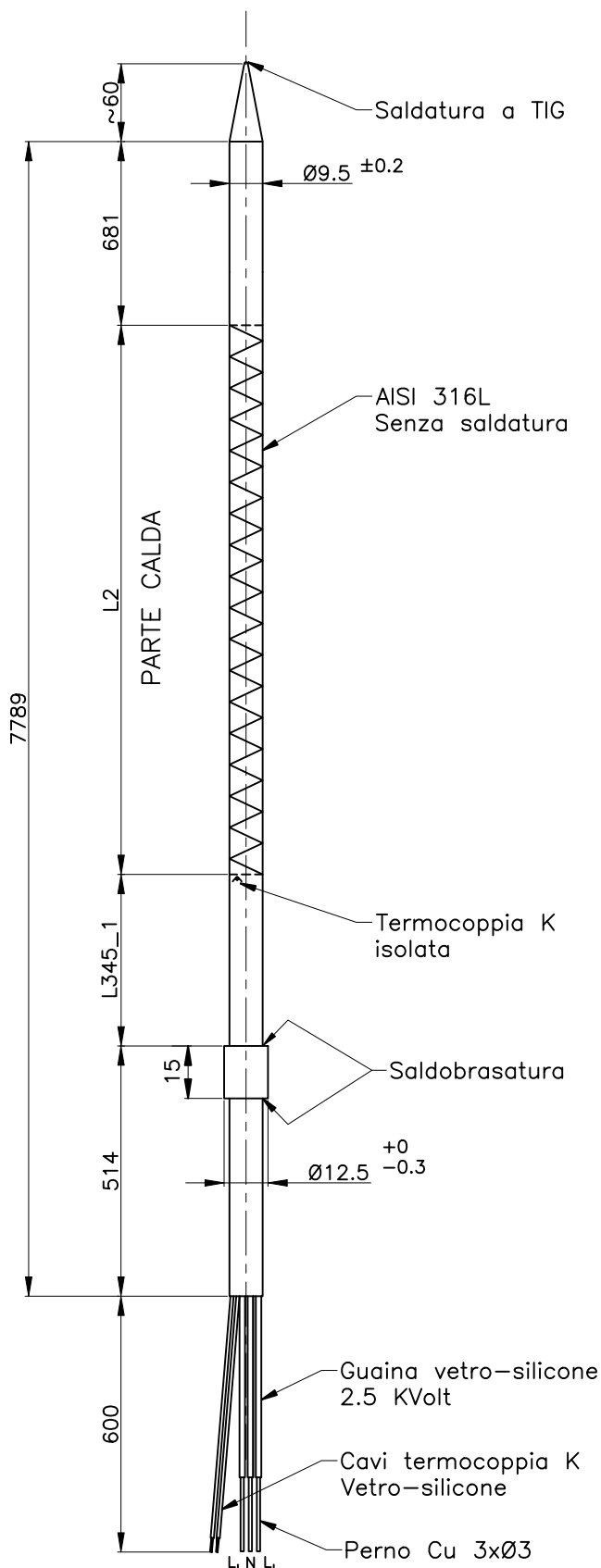
Specifica tecnica barre scaldanti secondo fornitore



DATI TECNICI :	
-	<u>NORMAL ROD</u>
	L2 = 4191
	L345_1 = 2403
	P(a caldo) = 27600W
	COD. = SPXS003301
-	<u>HOT ROD</u>
	L2 = 3825
	L345_1 = 2769
	P(a caldo) = 30250W
	COD. = SPXS003302
	Alimentazione = 127Vdc

Disegnatore Drafted by M.DINICE	Controllato da Fabbr.	Checked by R. & S.	Nome file File name D100191	Rev.	Data Date 05/08/10	ScalaScale NO SCALA
 ROTFIL s.r.l. Pianezza (TO) ITALY		Titolo Title CARTUCCIA SUPERMAX			Materiale Material	
		Disegno N. Drawing No. D100191	Cliente/Codice Customer/Part. No.	RDR	Foglio Sheet 1/1	 

Allegato 28:

Posizione termocoppie su barra scaldante per primo fornitore

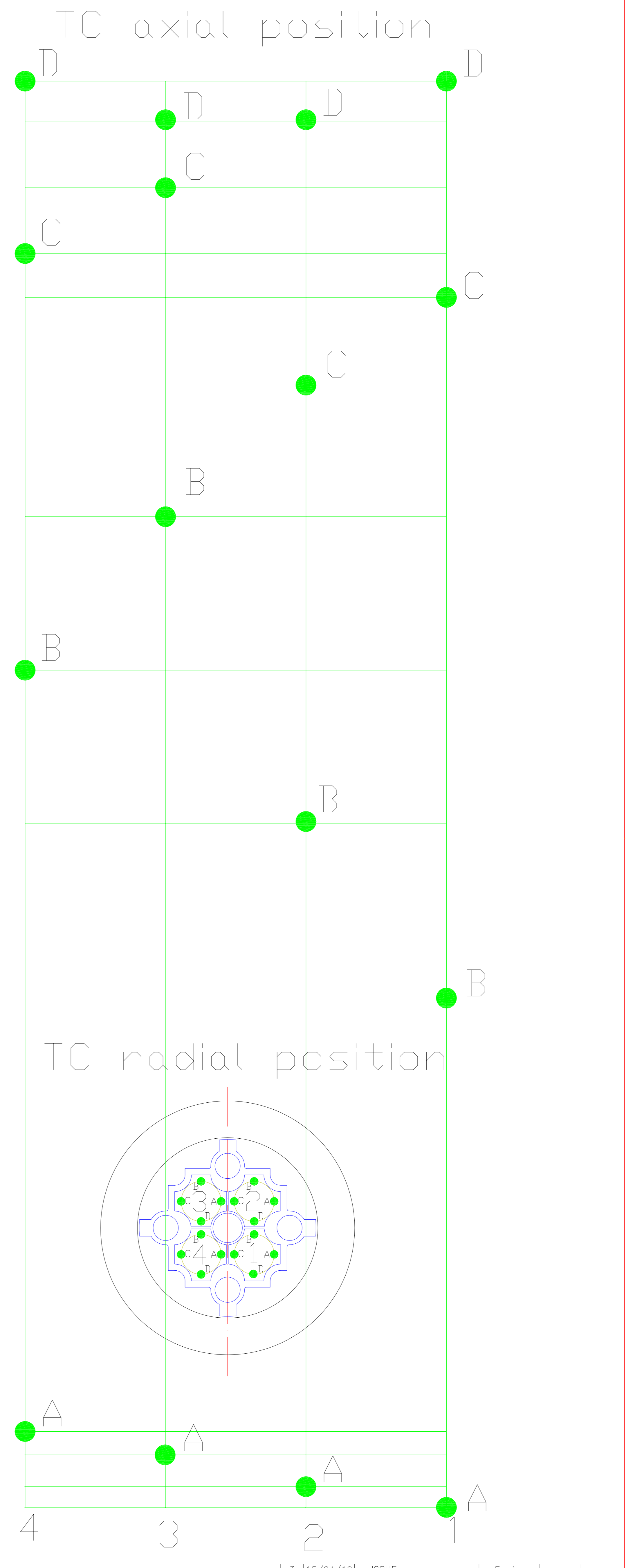
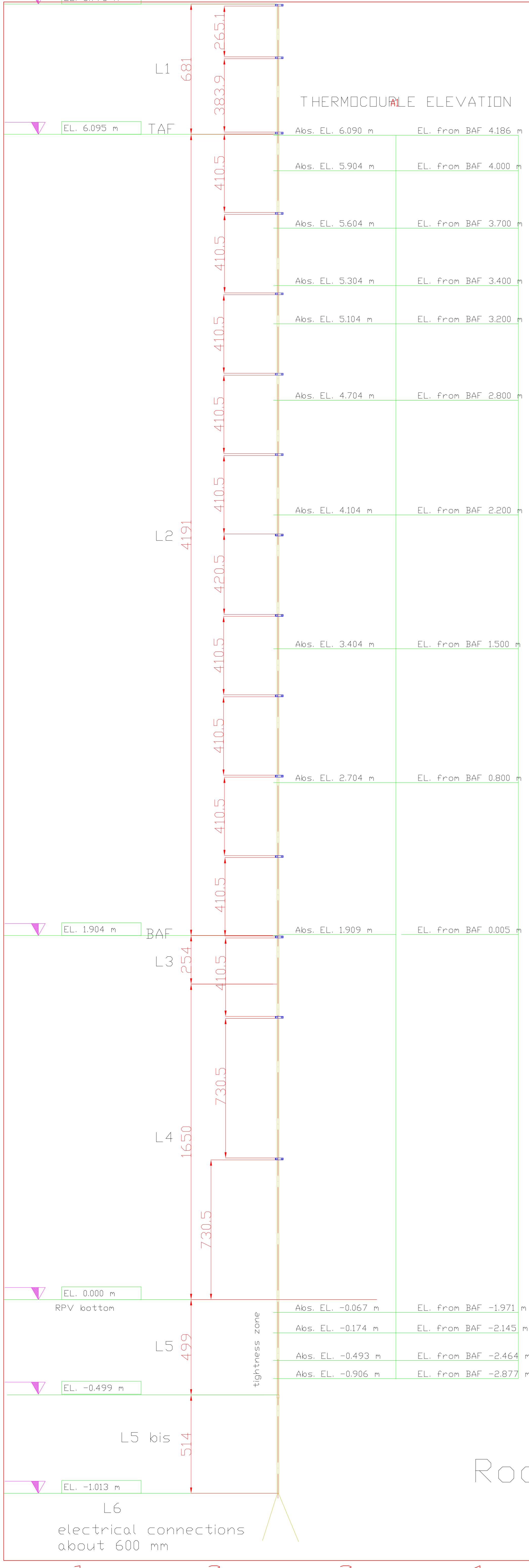

Rod number

Rev.	Date	Modify	Dftm.	Controll.	Approv.
3	15/04/10	ISSUE		Ferri	
1	31/03/10	ISSUE		Ferri	
0	8/09/09	DRAFT		Greco	
---	---	---		---	---

		SPES3-IRIS circuito prova barre	
PIACENZA ITALY		HEATER ROD POSITION	
Scale	Dwg. code	File	General code
1:10	074.00.01 TC	074.00.01 rev3 R0.dwg	

File name:

Allegato 29:

Posizione termocoppie su barra scaldante per secondo fornitore

THERMOCOUPLE ELEVATION

TC axial position

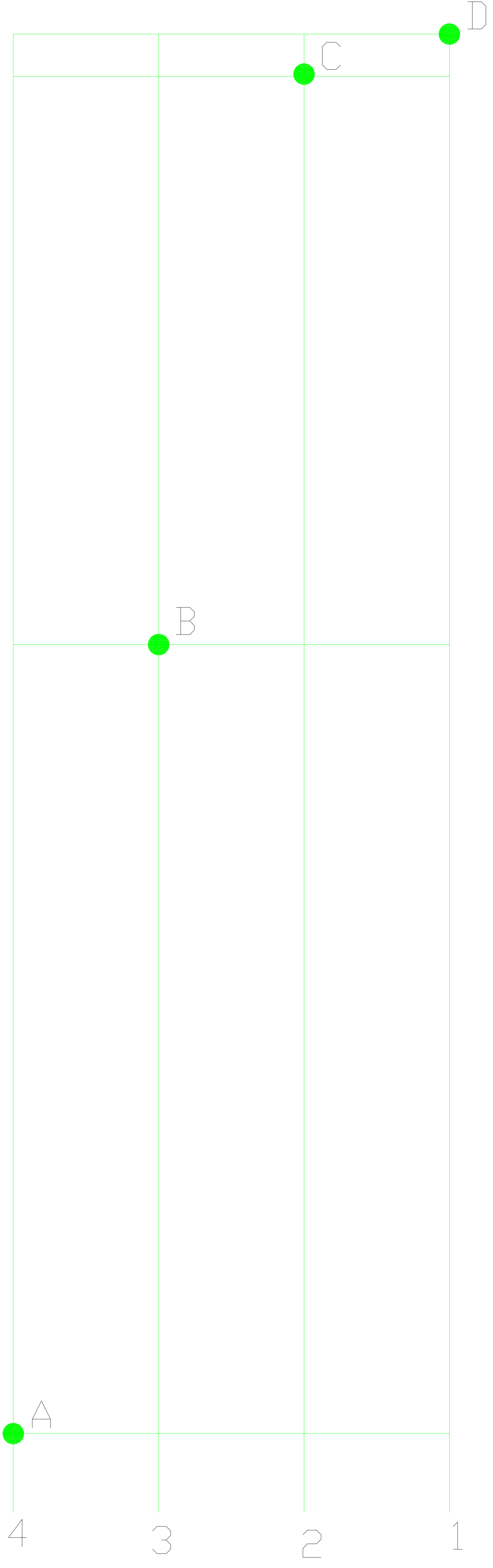
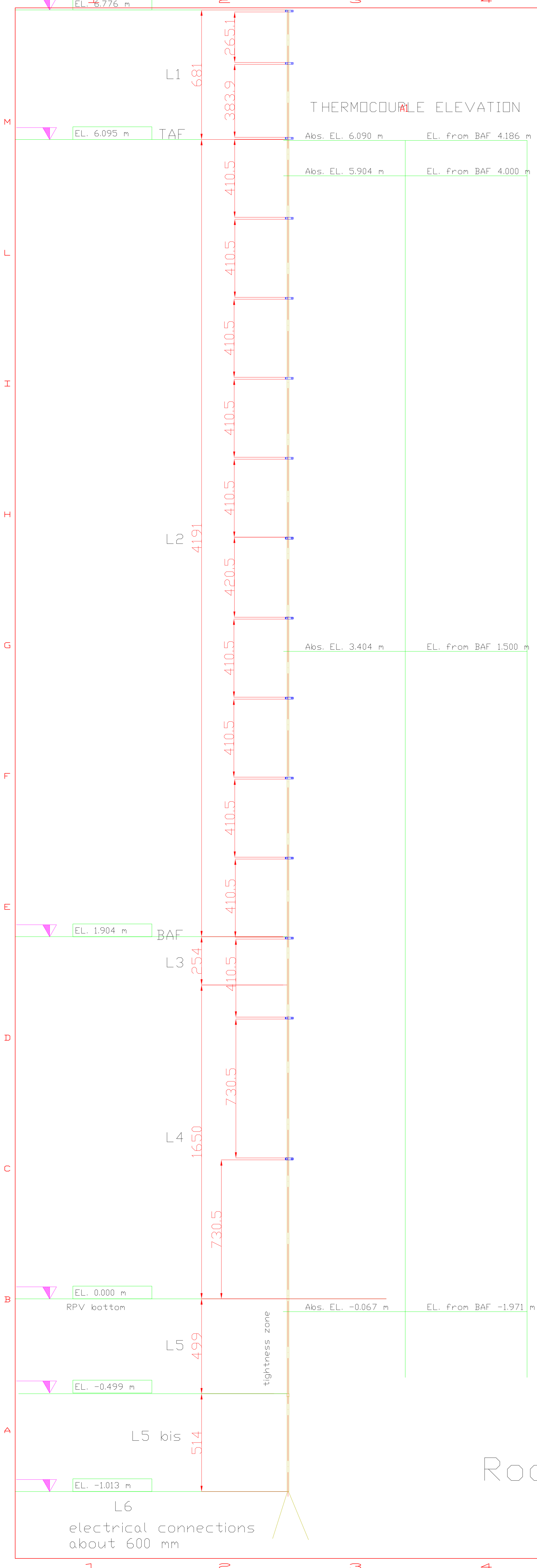

Rod number

3	15/04/10	ISSUE	Ferri, Greco		
1	31/03/10	ISSUE	Ferri		
0	8/09/09	DRAFT	Greco		
Rev.	Date	Modify	Dftm.	Controll.	Approv.
			SPES3-IRIS circuito prova barre		
PIACENZA ITALY			HEATER ROD POSITION		
Scale	Dwg code	File	General code		
1:10	074.00.01 TC	074.00.01 rev3 R0.dwg			

File name:

Allegato 30:

Calcolo ΔT barretta

Calcolo per circuito prova barre

Portata su IRIS	47.70 kg/s	
Portata scalata al 65% della potenza su Spes 3	31.01 kg/s	
Potenza singola barra (normal rod)	27612 W	
Potenza singola barra (hot rod)	33135 W	
Potenza totale circuito prova barre	121494 W	
Portata scalata su circuito	0.58 kg/s	
\varnothing int tubo 2"	0.04283 m	
Area tubo	1.44E-03 m ²	
Diametro barretta	0.0095 m	
Area barretta	7.09E-05 m ²	
Diametro sostegni barre spaziatrici	0.008 m	
Area barretta sostegno	5.03E-05 m ²	
Area utile	9.56E-04 m ²	
Perimetro bagnato	0.35 m	
Dh	0.01 m	
Altezza utile	4.191 m	
Superficie laterale di una barretta	0.13 m ²	
Pressione di esercizio	155 bar	
Temperatura media di esercizio impianto prova barre	297 °C	Media tra 278 °C (Tin) e 316°C (Tout)
ρ_{H_2O}	732.61 kg/m ³	
μ	8.97E-05 Pa*s	
cp	5387.72 J/kg°C	
K	0.57 W/mK	
velocità	0.83 m/s	
Re	72919.99	
Pr	0.86	
Nu	167.80	
h	8788.70 W/m ² K	
Area laterale totale	0.50 m ²	
Flusso	242830.76 W/m ²	riferito alle 4 barre
DeltaT	27.63 °C	
Temperatura di parete barretta	324.63 °C	

Calcolo per spes 3

Temperatura media di esercizio impianto SPES3	311 °C	Media tra 292 °C (Tin) e 330°C (Tout)
μ	8.42E-05 Pa*s	
cp	5777.54 J/kg°C	
K	0.54 W/mK	
Dh	0.01 m	
ρ_{H_2O}	702.45 kg/m ³	
velocità	2.15 m/s	
Re	187738.13	
A utile	0.02 m ²	
cp	5777.54 J/kg°C	
Pr	0.90	
Nu	365.52	
h	18805.99 W/m ² K	
Potenza Iris (235 barre+1 dummy)	6500000 W	
Area laterale totale	29.52 m ²	
Flusso	220196.40 W/m ²	riferito alle 235 barre
DeltaT	11.71 °C	
Temperatura di parete barretta	322.71 °C	

Allegato 31:

Specifica tecnica kalrez



Kalrez® perfluoroelastomer parts

From DuPont Performance Elastomers

Kalrez® Spectrum™ 7090

Product Description

Kalrez® Spectrum™ perfluoroelastomer parts made from compound 7090 are specifically targeted for use in applications requiring high hardness/higher modulus properties. These specialty black parts have excellent mechanical properties including compression set resistance, seal force retention, response to temperature cycling effects and rapid gas decompression resistance. Kalrez® Spectrum™ 7090 perfluoroelastomer parts are well suited for both static and dynamic sealing applications, especially applications that require extrusion resistance at higher temperatures. They also offer outstanding thermal stability and chemical resistance. A maximum continuous service temperature of 325°C (617°F) is suggested. Short excursions to higher temperatures may also be possible.

Typical Physical Properties ¹

Color	Black
Hardness, Shore A ²	90
50% Modulus ³ , MPa (psi)	15.50 (2248)
Tensile Strength at Break ³ , MPa (psi)	22.75 (3300)
Elongation at Break ³ , %	75
Compression Set ⁴ , %	
70 hr @ 204°C	12
70 hr @ 260°C	23
Temperature of Retraction, Tr10 ⁵ , °C (°F)	-5 (23)
Maximum Continuous Service Temperature ⁶ , °C (°F)	325°C (617°F)

¹ Not to be used for specification purposes

² ASTM D2240 (pellet test specimens)

³ ASTM D1414 & D412 (AS568 K214 O-ring test specimens)

⁴ ASTM D1414 & D395B (AS568 K214 O-ring test specimens)

⁵ ASTM D1329 (dumbbell test specimens/test specimens stretched 25%)

⁶ DuPont Performance Elastomers proprietary test method

Performance Features/Benefits

- Higher hardness and modulus
- Exceptional thermal stability and compression set resistance
- Outstanding seal force retention properties and response to temperature cycling effects
- Excellent mechanical properties
- Lower coefficient of thermal expansion (CTE) versus other Kalrez® parts thus minimizing the need to increase the free volume of the seal gland when upgrading from fluoroelastomers (FKM) to perfluoroelastomers (FFKM)

Long-Term Compression Set in Hot Air¹

672 Hours at 260°C (500°F)

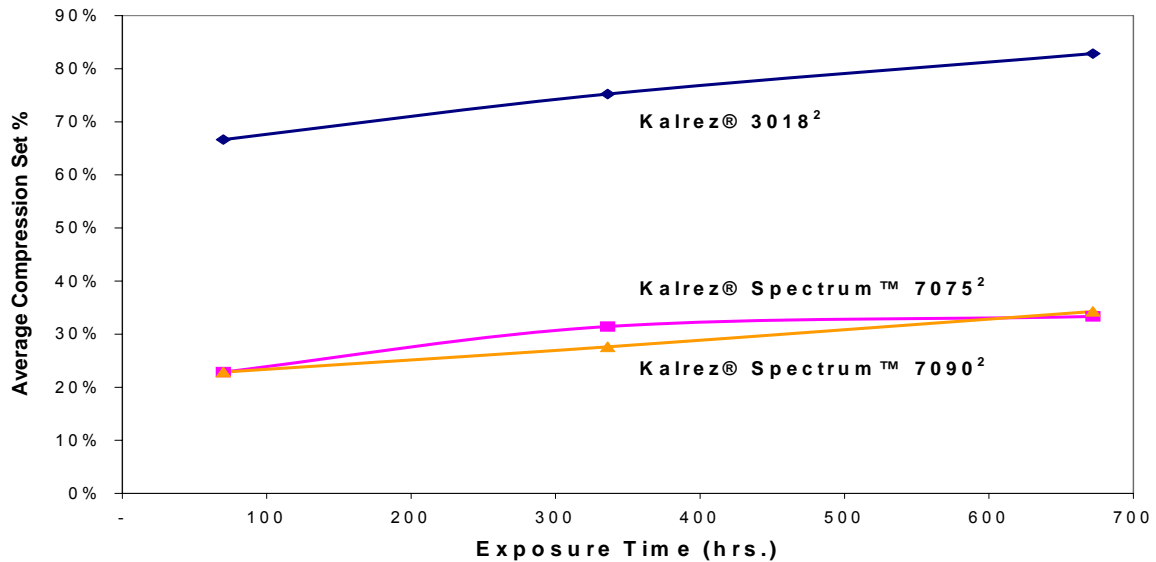

¹ Not to be used for specification purposes

² ASTM D1414 & D395B (AS568 K214 O-ring test specimens)

For further information please contact one of the offices below, or visit our website at www.dupontelastomers.com/kalrez

Global Headquarters – Wilmington, DE USA

Tel. +1-800-8 53-5515
+1-302-7 92-4000
Fax +1-302-7 92-4450

European Headquarters - Geneva

Tel. +41-22-7 17-4000
Fax +41-22-7 17-4001

South & Central America Headquarters - Brazil

Tel. +55-11-4 166-8978
Fax +55-11-4 166-8989

Asia Pacific Headquarters - Singapore

Tel. +65-6275 -9383
Fax +65-6275 -9395

Japan Headquarters – Tokyo

Tel. +81-3-55 21-2990
Fax. +81-3-5521-2991

The information set forth herein is furnished free of charge and is based on technical data that DuPont Performance Elastomers believes to be reliable. It is intended for use by persons having technical skill, at their own discretion and risk. Handling precaution information is given with the understanding that those using it will satisfy themselves that their particular conditions of use present no health or safety hazards. Since conditions of product use and disposal are outside our control, we make no warranties, express or implied, and assume no liability in connection with any use of this information. As with any material, evaluation of any compound under end-use conditions prior to specification is essential. Nothing herein is to be taken as a license to operate or a recommendation to infringe on patents. While the information presented here is accurate at the time of publication, specifications can change. Check www.dupontelastomers.com for the most up-to-date information.

Caution: Do not use in medical applications involving permanent implantation in the human body. For other medical applications, discuss with your DuPont Performance Elastomers customer service representative and read Medical Caution Statement H-69237.

DuPont™ is a trademark of DuPont and its affiliates.

Kalrez® and Kalrez® Spectrum™ are registered trademarks or trademarks of DuPont Performance Elastomers.

Copyright © 2007 DuPont Performance Elastomers. All Rights Reserved.

(06/07) Printed in U.S.A.

Reorder no: KZE-A10576-00-A0607

DuPont
Performance Elastomers

Allegato 32:

Calcoli strutturali e risultati con Autopipe Plus V8.i

Allegato 32

Calcoli strutturali e risultati con Autopipe Plus V8.i

Il report dei risultati dà una descrizione puntuale del circuito e delle caratteristiche dei componenti, con i pesi dei singoli, ivi comprese flange e valvole, il peso dell'impianto e del suo contenuto, le caratteristiche dei materiali, le condizioni operative, le combinazioni di carico, con gli spostamenti e le rotazioni di ogni singolo punto, e dei supporti, ad esse associate, forze, momenti, tensioni, deformazioni di ogni singolo punto, carichi e caratteristiche dei supporti, la conformità col codice verificata per ogni singolo punto, nonché un sommario dei risultati in cui sono evidenziati i punti nei quali si concentrano i carichi e le combinazioni di carico maggiori, e dichiara la conformità dei calcoli eseguiti alla norma UNI EN 13480:2002.

A seguire è allegato l'output del calcolo eseguito con Autopipe, completo di tutti gli elementi già descritti.

CIRCUITOPROVABARRE
07/30/2010 CIRCUITO PROVA BARRE
BENTLEY
02:16 PM
AutoPIPE Plus 9.2.1 MODEL PAGE 1

```

      *
     ***
    ** **
   ** **      **
  ** **      **
 *** **      **
**** **      **
** **      **
** **      **

```

Pipe Stress Analysis and Design Program

Version: 09.02.01.07

Edition: Plus

Developed and Maintained by

BENTLEY SYSTEMS, INCORPORATED
1600 Riviera Ave., Suite 300
Walnut Creek, CA 94596

□

CIRCUITOPROVABARRE
07/30/2010 CIRCUITO PROVA BARRE
BENTLEY
02:16 PM
AutoPIPE Plus 9.2.1 MODEL PAGE 2

```

*****
**
**      AUTOPIPE SYSTEM INFORMATION      **
**
*****

```

SYSTEM NAME : CIRCUITOPROVABARRE

circuitoprovabarre.txt
PROJECT ID : CIRCUITO PROVA BARRE

PREPARED BY : _____
CONGIU

CHECKED BY : _____
ACHILLI

1ST APPROVER : _____

2ND APPROVER : _____

PIPING CODE : EN 13480
YEAR : 2002
LIFETIME (HRS) : 10000
LIFETIME MONITORING : NO
VERTICAL AXIS : Z
AMBIENT TEMPERATURE : 20.0 deg C
COMPONENT LIBRARY : AUTOPIPE
MATERIAL LIBRARY : EUROMAT
MODEL REVISION NUMBER : 259

□

CIRCUITOPROVABARRE

07/30/2010 CIRCUITO PROVA BARRE
BENTLEY

02:16 PM

AutoPIPE Plus 9.2.1 MODEL PAGE 3

C O M P O N E N T D A T A L I S T I N G

*** SEGMENT A

From A20 to A19, DZ= 449.00 mm

Run

PIPE DATA:

Pipe Id= TENUTAIN, Material= X5CRNI18-10 1.4301, Product=
Seamless tube, Source= EURO,
Composition= Austentic Stainless, Poisson= 0.300, Nom Size= Non-standard, OD=
63.000 mm, Sch= Non-standard,
Wall Thk= 10.500 mm, Mill= 1.312 mm, Cor= 0 mm, Pipe Density= 7930.00 kg/m3,
Pipe Unit wgt= 134.68 N/m, Content Sp Gr= 1.000,
Content Unit wgt= 13.58 N/m, Insul Thk= 40.000 mm, Insul Density= 136.16
kg/m3, Insul Unit wgt= 17.28 N/m, Lining Thk= 0 mm,
Long weld factor= 1.00, Circ weld factor= 1.00, Long Modulus= 0.19996 E6
N/mm2, Hoop Modulus= 0.19996 E6 N/mm2,
Shear Modulus= 0.07691 E6 N/mm2, A1= 40.0, At= 35.0, fc= 166.7 N/mm2, Rp0.2=

Pagina 2

circuitoprovabarre.txt

195.0 N/mm2, Rp1.0= 230.0 N/mm2,
Rm= 500.0 N/mm2

OPERATING DATA:

P1= 17.2500 N/mm2, P2= 10.0000 N/mm2, P3= 0.5000 N/mm2, T1= 330.00 deg C, T2= 330.00 deg C, T3= 120.00 deg C,
Exp1= 5.38910 mm/m, Exp2= 5.38910 mm/m, Exp3= 1.60340 mm/m, E1= 0.17368 E6 N/mm2, E2= 0.17368 E6 N/mm2, E3= 0.19148 E6 N/mm2,
Rp0.2t1= 106.40 N/mm2, Rp0.2t2= 106.40 N/mm2, Rp0.2t3= 149.00 N/mm2, Rp1.0t1= 131.40 N/mm2, Rp1.0t2= 131.40 N/mm2,
Rp1.0t3= 182.00 N/mm2, Rmt1= 0.00 N/mm2, Rmt2= 0.00 N/mm2, Rmt3= 0.00 N/mm2,
fcr1= 0.00 N/mm2, fcr2= 0.00 N/mm2,
fcr3= 0.00 N/mm2, fh1= 87.60 N/mm2, fh2= 87.60 N/mm2, fh3= 121.33 N/mm2

POINT DATA:

A20, Coordinates, X= 0.00 mm, Y= 0.00 mm, Z= 1200.00 mm
A20, Flange= NS, Rating= 2500, Flange weight= 11.00 kg, Bolt/Nut weight= 0.00 kg, End type= User-defined, SIF= 1.00,
Perform ANSI check= No
A20, Flange= NS, Rating= 2500, Flange weight= 14.00 kg, Bolt/Nut weight= 0.00 kg, End type= User-defined, SIF= 1.00,
Perform ANSI check= No
A20, Added weight= 105.00 kg

From A19 to A18, DZ= 449.00 mm

Run

PIPE DATA:

Pipe Id= 2SCH160, Composition= Austentic Stainless, Nom Size= 50 mm, OD= 60.325 mm, Sch= 160, wall Thk= 8.738 mm,
Mill= 1.092 mm, Content Sp Gr= 1.000, Content Unit wgt= 14.14 N/m, Insul Density= 136.16 kg/m3, Insul Unit wgt= 16.83 N/m

POINT DATA:

A19, Coordinates, X= 0.00 mm, Y= 0.00 mm, Z= 1649.00 mm

From A18 to A17, DZ= 637.50 mm

Run

POINT DATA:

A18, Coordinates, X= 0.00 mm, Y= 0.00 mm, Z= 2098.00 mm
A18, Flange= WELDNECK, Rating= 2500, Flange weight= 19.10 kg, Bolt/Nut weight= 0.00 kg, End type= weld neck, SIF= 1.00,
Perform ANSI check= No
A18, Flange= WELDNECK, Rating= 2500, Flange weight= 19.10 kg, Bolt/Nut weight= 0.00 kg, End type= weld neck, SIF= 1.00,
Perform ANSI check= No

From A17 to A15, DZ= 63.50 mm

Run

POINT DATA:

A17, Coordinates, X= 0.00 mm, Y= 0.00 mm, Z= 2735.50 mm

□

CIRCUITOPROVABARRE

07/30/2010 CIRCUITO PROVA BARRE
BENTLEY

02:16 PM

AutoPIPE Plus 9.2.1 MODEL PAGE 4

C O M P O N E N T D A T A L I S T I N G

circuitprovabarre.txt

A17, Joint End Type= Butt welded, Joint offset= 0.000 mm, SIFI= 1.00, SIFO= 1.00, Override all other values= Yes

From A15 to A16, DZ= 63.50 mm Tee

COMPONENT DATA (Tee Header, Center= A15):
B16.9 welding tee, SIFI= 1.00, SIFO= 1.00

POINT DATA:

A15, Coordinates, X= 0.00 mm, Y= 0.00 mm, Z= 2799.00 mm
A15, Joint End Type= Socket welded, SIFI= 2.10, SIFO= 2.10, Override all other values= Yes

From A16 to A22, DZ= 1500.00 mm Run

POINT DATA:

A16, Coordinates, X= 0.00 mm, Y= 0.00 mm, Z= 2862.50 mm

From A22 to A14, DZ= 3971.50 mm Run

POINT DATA:

A22, Coordinates, X= 0.00 mm, Y= 0.00 mm, Z= 4362.50 mm

SUPPORT DATA:

A22, Guide, Support Id= A22 1, Connected to Ground, Stiffness= RIGID

From A14 to A04, DZ= 2446.00 mm Run

POINT DATA:

A14, Coordinates, X= 0.00 mm, Y= 0.00 mm, Z= 8334.00 mm
A14, Flange= WELDNECK, Rating= 2500, Flange weight= 19.10 kg, Bolt/Nut weight= 0.00 kg, End type= weld neck, SIF= 1.00, Perform ANSI check= No
A14, Flange= WELDNECK, Rating= 2500, Flange weight= 19.10 kg, Bolt/Nut weight= 0.00 kg, End type= weld neck, SIF= 1.00, Perform ANSI check= No

From A04 to A03, DZ= 284.20 mm Run

POINT DATA:

A04, Coordinates, X= 0.00 mm, Y= 0.00 mm, Z= 10780.00 mm
A04, Flange= WELDNECK, Rating= 2500, Flange weight= 19.10 kg, Bolt/Nut weight= 0.00 kg, End type= weld neck, SIF= 1.00, Perform ANSI check= No
A04, Flange= WELDNECK, Rating= 2500, Flange weight= 19.10 kg, Bolt/Nut weight= 0.00 kg, End type= weld neck, SIF= 1.00, Perform ANSI check= No

From A03 to A00, DY= 76.20 mm Bend

COMPONENT DATA (Bend, TIP= A03, Near= A03 N, Mid= A03 M, Far= A03 F):
Long Elbow, Radius= 76.20 mm, Bend angle= 90.00 deg, Mid point at 50.00 percent, End flanges= 0, Flex= Auto, SIFI= 1.00, SIFO= 1.00

POINT DATA:

□

CIRCUITPROVABARRE

C O M P O N E N T D A T A L I S T I N G

A03, Coordinates, X= 0.00 mm, Y= 0.00 mm, Z= 11064.20 mm
 A03 N, Coordinates, X= 0.00 mm, Y= 0.00 mm, Z= 10988.00 mm
 A03 M, Coordinates, X= 0.00 mm, Y= 22.22 mm, Z= 11041.79 mm
 A03 F, Coordinates, X= 0.00 mm, Y= 75.56 mm, Z= 11064.20 mm
 A03 F, Joint End Type= Socket welded, SIFI= 2.10, SIFO= 2.10, override all
 other values= Yes

From A00 to A25, DY= 25.80 mm Run

POINT DATA:

A00, Coordinates, X= 0.00 mm, Y= 76.20 mm, Z= 11064.20 mm

From A25 to A01, DY= 37.70 mm Run

POINT DATA:

A25, Coordinates, X= 0.00 mm, Y= 102.00 mm, Z= 11064.20 mm

SUPPORT DATA:

A25, Guide, Support Id= A25 1, Connected to Ground, Stiffness= RIGID

From A01 to A05, DY= 1657.10 mm Tee

COMPONENT DATA (Tee Header, Center= A01):

B16.9 welding tee, SIFI= 1.00, SIFO= 1.00

POINT DATA:

A01, Coordinates, X= 0.00 mm, Y= 139.70 mm, Z= 11064.20 mm

A01, Joint End Type= Socket welded, SIFI= 2.10, SIFO= 2.10, override all
 other values= Yes

From A05 to A07, DY= 63.50 mm Run

POINT DATA:

A05, Coordinates, X= 0.00 mm, Y= 1796.80 mm, Z= 11064.20 mm

From A07 to A26, DY= 37.70 mm Tee

COMPONENT DATA (Tee Header, Center= A07):

B16.9 welding tee, SIFI= 1.00, SIFO= 1.00

POINT DATA:

A07, Coordinates, X= 0.00 mm, Y= 1860.30 mm, Z= 11064.20 mm

A07, Joint End Type= Socket welded, SIFI= 2.10, SIFO= 2.10, override all
 other values= Yes

From A26 to A08, DY= 25.80 mm Run

POINT DATA:

A26, Coordinates, X= 0.00 mm, Y= 1898.00 mm, Z= 11064.20 mm

SUPPORT DATA:

circuitoprovabarre.txt
A26, Guide, Support Id= A26 1, Connected to Ground, Stiffness= RIGID

□

CIRCUITOPROVABARRE

07/30/2010 CIRCUITO PROVA BARRE
BENTLEY

02:16 PM

AutoPIPE Plus 9.2.1 MODEL PAGE 6

C O M P O N E N T D A T A L I S T I N G

From A08 to A09, DY= 76.20 mm Run

POINT DATA:

A08, Coordinates, X= 0.00 mm, Y= 1923.80 mm, Z= 11064.20 mm

From A09 to A11, DZ= -76.20 mm Bend

COMPONENT DATA (Bend, TIP= A09, Near= A09 N, Mid= A09 M, Far= A09 F):
Long Elbow, Radius= 76.20 mm, Bend angle= 90.00 deg, Mid point at 50.00
percent, End flanges= 0, Flex= Auto, SIFI= 1.00,
SIFO= 1.00

POINT DATA:

A09, Coordinates, X= 0.00 mm, Y= 2000.00 mm, Z= 11064.20 mm
A09 N, Coordinates, X= 0.00 mm, Y= 1924.44 mm, Z= 11064.20 mm
A09 M, Coordinates, X= 0.00 mm, Y= 1977.68 mm, Z= 11041.88 mm
A09 F, Coordinates, X= 0.00 mm, Y= 2000.00 mm, Z= 10988.63 mm

From A11 to A10, DZ= -63.50 mm Run

POINT DATA:

A11, Coordinates, X= 0.00 mm, Y= 2000.00 mm, Z= 10988.00 mm

From A10 to A12, DZ= -63.50 mm Tee

COMPONENT DATA (Tee Header, Center= A10):
B16.9 welding tee, SIFI= 1.00, SIFO= 1.00

POINT DATA:

A10, Coordinates, X= 0.00 mm, Y= 2000.00 mm, Z= 10924.50 mm
A10, Joint End Type= Socket welded, SIFI= 2.10, SIFO= 2.10, override all
other values= Yes

From A12 to A13, DZ= -127.00 mm Run

POINT DATA:

A12, Coordinates, X= 0.00 mm, Y= 2000.00 mm, Z= 10861.00 mm
A13, Coordinates, X= 0.00 mm, Y= 2000.00 mm, Z= 10734.00 mm
A13, Flange= WELDNECK, Rating= 2500, Flange weight= 19.10 kg, Bolt/Nut
weight= 0.00 kg, End type= weld neck, SIF= 1.00,
Perform ANSI check= No
A13, Flange= WELDNECK, Rating= 2500, Flange weight= 19.10 kg, Bolt/Nut
weight= 0.00 kg, End type= weld neck, SIF= 1.00,
Perform ANSI check= No

circuitoprovabarre.txt

*** SEGMENT B

From A01 to B01, DZ= 122.20 mm

Tee

COMPONENT DATA (Tee Branch, Center= A01):
B16.9 welding tee, SIFI= 1.00, SIFO= 1.00

□

CIRCUITOPROVABARRE

07/30/2010 CIRCUITO PROVA BARRE
BENTLEY

02:16 PM

AutoPIPE Plus 9.2.1 MODEL PAGE 7

C O M P O N E N T D A T A L I S T I N G

PIPE DATA:

Pipe Id= 3/4S160, Composition= Austentic Stainless, Nom Size= 20 mm, OD= 26.670 mm, wall Thk= 5.563 mm, Mill= 0.695 mm,
Content Sp Gr= 1.000, Content Unit wgt= 1.86 N/m, Insul Density= 136.16 kg/m3, Insul Unit wgt= 11.19 N/m

OPERATING DATA:

T1= 354.00 deg C, T2= 354.00 deg C, T3= 152.00 deg C, Exp1= 5.85176 mm/m, Exp2= 5.85176 mm/m, Exp3= 2.14622 mm/m,
E1= 0.17164 E6 N/mm2, E2= 0.17164 E6 N/mm2, E3= 0.18877 E6 N/mm2, Rp0.2t1= 103.52 N/mm2, Rp0.2t2= 103.52 N/mm2,
Rp0.2t3= 139.48 N/mm2, Rp1.0t1= 128.68 N/mm2, Rp1.0t2= 128.68 N/mm2, Rp1.0t3= 169.40 N/mm2, fh1= 85.79 N/mm2,
fh2= 85.79 N/mm2, fh3= 112.93 N/mm2

POINT DATA:

A01, Coordinates, X= 0.00 mm, Y= 139.70 mm, Z= 11064.20 mm
A01, Joint End Type= Socket welded, SIFI= 2.10, SIFO= 2.10, Override all other values= Yes

From B01 to B02, DZ= 90.00 mm

Run

POINT DATA:

B01, Coordinates, X= 0.00 mm, Y= 139.70 mm, Z= 11186.40 mm
B01, Flange= WELDNECK, Rating= 2500, Flange weight= 4.10 kg, Bolt/Nut weight= 0.00 kg, End type= weld neck, SIF= 1.00,
Perform ANSI check= No
B01, Flange= WELDNECK, Rating= 2500, Flange weight= 4.10 kg, Bolt/Nut weight= 0.00 kg, End type= weld neck, SIF= 1.00,
Perform ANSI check= No

From B02 to B03, DZ= 64.00 mm

Redu

COMPONENT DATA (Reducer):
Length= 64.00 mm, SIF= 2.00

POINT DATA:

B02, Coordinates, X= 0.00 mm, Y= 139.70 mm, Z= 11276.40 mm

From B03 to B04, DZ= 89.00 mm

Redu

COMPONENT DATA (Reducer):

Length= 89.00 mm, SIF= 2.00

PIPE DATA:

Pipe Id= 1.5IS160, Composition= Austentic Stainless, Nom Size= 40 mm, OD= 48.260 mm, wall Thk= 7.137 mm, Mill= 0.892 mm, Content Sp Gr= 1.000, Content Unit wgt= 8.89 N/m, Insul Density= 136.16 kg/m3, Insul Unit wgt= 14.81 N/m

POINT DATA:

B03, Coordinates, X= 0.00 mm, Y= 139.70 mm, Z= 11340.40 mm

From B04 to B09, DZ= 616.00 mm

Run

PIPE DATA:

Pipe Id= 2.5IS160, Composition= Austentic Stainless, Nom Size= 65 mm, OD= 73.025 mm, wall Thk= 9.525 mm, Mill= 1.191 mm, Content Sp Gr= 1.000, Content Unit wgt= 22.43 N/m, Insul Density= 136.16 kg/m3, Insul Unit wgt= 18.96 N/m, Long Modulus= 0.19996 E6 N/mm2, Hoop Modulus= 0.19996 E6 N/mm2, Shear Modulus= 0.07691 E6 N/mm2

POINT DATA:

□

CIRCUITOPROVABARRE

07/30/2010 CIRCUITO PROVA BARRE
BENTLEY

02:16 PM

AutoPIPE Plus 9.2.1 MODEL PAGE 8

C O M P O N E N T D A T A L I S T I N G

B04, Coordinates, X= 0.00 mm, Y= 139.70 mm, Z= 11429.40 mm

From B09 to B05, DZ= 3681.68 mm

Run

POINT DATA:

B09, Coordinates, X= 0.00 mm, Y= 139.70 mm, Z= 12045.40 mm

SUPPORT DATA:

B09, Guide, Support Id= B09 1, Connected to Ground, Stiffness= RIGID

From B05 to B10, DZ= 66.16 mm

Tee

COMPONENT DATA (Tee Header, Center= B05):

B16.9 welding tee, SIFI= 1.00, SIFO= 1.00

POINT DATA:

B05, Coordinates, X= 0.00 mm, Y= 139.70 mm, Z= 15727.08 mm
B05, Joint End Type= Socket welded, SIFI= 2.10, SIFO= 2.10, override all other values= Yes

From B10 to B06, DZ= 66.16 mm

Run

POINT DATA:

circuitoprovabarre.txt

B10, Coordinates, X= 0.00 mm, Y= 139.70 mm, Z= 15793.24 mm

From B06 to B07, DZ= 89.00 mm Redu

COMPONENT DATA (Reducer):

Length= 89.00 mm, SIF= 2.00

POINT DATA:

B06, Coordinates, X= 0.00 mm, Y= 139.70 mm, Z= 15859.40 mm

From B07 to B08, DZ= 286.50 mm Run

PIPE DATA:

Pipe Id= 1INS80, Composition= Austentic Stainless, Nom Size= 25 mm, OD= 33.401 mm, Sch= 80, wall Thk= 4.547 mm, Mill= 0.568 mm, Content Sp Gr= 1.000, Content Unit wgt= 4.55 N/m, Insul Thk= 0 mm, Insul Material= OTHER, Long Modulus= 0.19996 E6 N/mm2, Hoop Modulus= 0.19996 E6 N/mm2, Shear Modulus= 0.07691 E6 N/mm2

POINT DATA:

B07, Coordinates, X= 0.00 mm, Y= 139.70 mm, Z= 15948.40 mm

B08, Coordinates, X= 0.00 mm, Y= 139.70 mm, Z= 16234.90 mm

B08, Flange= WELDNECK, Rating= 2500, Flange weight= 5.90 kg, Bolt/Nut weight= 0.00 kg, End type= weld neck, SIF= 1.00,

Perform ANSI check= No

B08, Flange= BLIND, Rating= 2500, Flange weight= 5.40 kg, Bolt/Nut weight= 0.00 kg, End type= User-defined, SIF= 1.00,

Perform ANSI check= No

B08, Added weight= 15.00 kg

□

CIRCUITOPROVABARRE

07/30/2010 CIRCUITO PROVA BARRE

BENTLEY

02:16 PM

AutoPIPE Plus 9.2.1 MODEL PAGE 9

C O M P O N E N T D A T A L I S T I N G

*** SEGMENT C

From A07 to C01, DZ= 169.50 mm Tee

COMPONENT DATA (Tee Branch, Center= A07):

B16.9 welding tee, SIFI= 1.00, SIFO= 1.00

PIPE DATA:

Pipe Id= 0.5INS16, Composition= Austentic Stainless, Nom Size= 15 mm, OD= 21.336 mm, Sch= 160, wall Thk= 4.775 mm, Mill= 0.597 mm, Content Sp Gr= 1.000, Content Unit wgt= 1.07 N/m

OPERATING DATA:

T1= 330.00 deg C, T2= 330.00 deg C, Exp1= 5.38910 mm/m, Exp2= 5.38910 mm/m, E1= 0.17368 E6 N/mm2, E2= 0.17368 E6 N/mm2, Rp0.2t1= 106.40 N/mm2, Rp0.2t2= 106.40 N/mm2, Rp1.0t1= 131.40 N/mm2, Rp1.0t2=

circuitoprovabarre.txt

131.40 N/mm2, fh1= 87.60 N/mm2,
fh2= 87.60 N/mm2

POINT DATA:

A07, Coordinates, X= 0.00 mm, Y= 1860.30 mm, Z= 11064.20 mm
A07, Joint End Type= Socket welded, SIFI= 2.10, SIFO= 2.10, Override all
other values= Yes
C01, Coordinates, X= 0.00 mm, Y= 1860.30 mm, Z= 11233.70 mm

*** SEGMENT D

From A10 to D01, DY= 50.80 mm Tee

COMPONENT DATA (Tee Branch, Center= A10):
B16.9 welding tee, SIFI= 1.00, SIFO= 1.00

PIPE DATA:

Pipe Id= 1INS80, Composition= Austentic stainless, Nom Size= 25 mm, OD=
33.401 mm, Sch= 80, Wall Thk= 4.547 mm,
Mill= 0.568 mm, Content Sp Gr= 1.000, Content Unit wgt= 4.55 N/m

OPERATING DATA:

T3= 120.00 deg C, Exp3= 1.60340 mm/m, E3= 0.19148 E6 N/mm2, Rp0.2t3= 149.00
N/mm2, Rp1.0t3= 182.00 N/mm2, fh3= 121.33 N/mm2

POINT DATA:

A10, Coordinates, X= 0.00 mm, Y= 2000.00 mm, Z= 10924.50 mm
A10, Joint End Type= Socket welded, SIFI= 2.10, SIFO= 2.10, Override all
other values= Yes

From D01 to D08, DY= 50.00 mm Run

OPERATING DATA:

T1= 20.00 deg C, Exp1= 0 mm/m, E1= 0.19996 E6 N/mm2, Rp0.2t1= 195.00 N/mm2,
Rp1.0t1= 230.00 N/mm2, fh1= 153.33 N/mm2

POINT DATA:

D01, Coordinates, X= 0.00 mm, Y= 2050.80 mm, Z= 10924.50 mm

From D08 to D02, DY= 565.41 mm Run

□

CIRCUITOPROVABARRE

07/30/2010 CIRCUITO PROVA BARRE
BENTLEY

02:16 PM AutoPIPE Plus 9.2.1 MODEL PAGE 10

C O M P O N E N T D A T A L I S T I N G

POINT DATA:

D08, Coordinates, X= 0.00 mm, Y= 2100.80 mm, Z= 10924.50 mm

From D02 to D03, DY= 38.10 mm Run

circuitprovabarre.txt

POINT DATA:

D02, Coordinates, X= 0.00 mm, Y= 2666.21 mm, Z= 10924.50 mm

From D03 to D04, DY= 38.10 mm

Tee

COMPONENT DATA (Tee Header, Center= D03):

B16.9 welding tee, SIFI= 1.00, SIFO= 1.00

POINT DATA:

D03, Coordinates, X= 0.00 mm, Y= 2704.31 mm, Z= 10924.50 mm

D03, Joint End Type= Socket welded, SIFI= 2.10, SIFO= 2.10, Override all other values= Yes

From D04 to D05, DY= 38.10 mm

Run

POINT DATA:

D04, Coordinates, X= 0.00 mm, Y= 2742.41 mm, Z= 10924.50 mm

From D05 to D06, DZ= -38.10 mm

Bend

COMPONENT DATA (Bend, TIP= D05, Near= D05 N, Mid= D05 M, Far= D05 F):

Long Elbow, Radius= 38.10 mm, Bend angle= 90.00 deg, Mid point at 50.00 percent, End flanges= 0, Flex= Auto, SIFI= 1.02, SIFO= 1.02

POINT DATA:

D05, Coordinates, X= 0.00 mm, Y= 2780.51 mm, Z= 10924.50 mm

D05 N, Coordinates, X= 0.00 mm, Y= 2743.04 mm, Z= 10924.50 mm

D05 M, Coordinates, X= 0.00 mm, Y= 2769.35 mm, Z= 10913.34 mm

D05 F, Coordinates, X= 0.00 mm, Y= 2780.51 mm, Z= 10887.03 mm

From D06 to D07, DZ= -96.00 mm

Run

POINT DATA:

D06, Coordinates, X= 0.00 mm, Y= 2780.51 mm, Z= 10886.40 mm

D07, Coordinates, X= 0.00 mm, Y= 2780.51 mm, Z= 10790.40 mm

D07, Flange= WELDNECK, Rating= 2500, Flange weight= 5.90 kg, Bolt/Nut weight= 0.00 kg, End type= weld neck, SIF= 1.00, Perform ANSI check= No

D07, Flange= WELDNECK, Rating= 2500, Flange weight= 5.90 kg, Bolt/Nut weight= 0.00 kg, End type= weld neck, SIF= 1.00, Perform ANSI check= No

*** SEGMENT F

From A15 to F01, DY= 63.50 mm

Tee

□

CIRCUITOPROVABARRE

07/30/2010 CIRCUITO PROVA BARRE
BENTLEY

02:16 PM

AutoPIPE Plus 9.2.1 MODEL PAGE 11

C O M P O N E N T D A T A L I S T I N G

circuitoprovabarre.txt

COMPONENT DATA (Tee Branch, Center= A15):
B16.9 welding tee, SIFI= 1.00, SIFO= 1.00

PIPE DATA:

Pipe Id= 2SCH160, Composition= Austentic Stainless, Nom Size= 50 mm, OD= 60.325 mm, Sch= 160, wall Thk= 8.738 mm, Mill= 1.092 mm, Content Sp Gr= 1.000, Content Unit wgt= 14.14 N/m, Insul Thk= 40.000 mm, Insul Material= MINERAL WOOL, Insul Density= 136.16 kg/m3, Insul Unit wgt= 16.83 N/m

OPERATING DATA:

T1= 292.00 deg C, T2= 40.00 deg C, Exp1= 4.66804 mm/m, Exp2= 0.30880 mm/m, E1= 0.17690 E6 N/mm2, E2= 0.19827 E6 N/mm2, Rp0.2t1= 111.28 N/mm2, Rp0.2t2= 195.00 N/mm2, Rp1.0t1= 136.60 N/mm2, Rp1.0t2= 230.00 N/mm2, fh1= 91.07 N/mm2, fh2= 153.33 N/mm2

POINT DATA:

A15, Coordinates, X= 0.00 mm, Y= 0.00 mm, Z= 2799.00 mm
A15, Joint End Type= Socket welded, SIFI= 2.10, SIFO= 2.10, Override all other values= Yes

From F01 to F02, DY= 240.50 mm Run

POINT DATA:

F01, Coordinates, X= 0.00 mm, Y= 63.50 mm, Z= 2799.00 mm
F01, Joint End Type= Butt welded, Joint offset= 0.000 mm, SIFI= 1.00, SIFO= 1.00, Override all other values= Yes

From F02 to F13, DY= 276.00 mm Run

POINT DATA:

F02, Coordinates, X= 0.00 mm, Y= 304.00 mm, Z= 2799.00 mm
F02, Flange= WELDNECK, Rating= 2500, Flange weight= 19.10 kg, Bolt/Nut Weight= 0.00 kg, End type= weld neck, SIF= 1.00, Perform ANSI check= No
F02, Flange= WELDNECK, Rating= 2500, Flange weight= 19.10 kg, Bolt/Nut Weight= 0.00 kg, End type= weld neck, SIF= 1.00, Perform ANSI check= No

From F13 to F03, DY= 1216.80 mm Tee

COMPONENT DATA (Tee Header, Center= F13):
B16.9 welding tee, SIFI= 1.00, SIFO= 1.00

OPERATING DATA:

T2= 292.00 deg C, Exp2= 4.66804 mm/m, E2= 0.17690 E6 N/mm2, Rp0.2t2= 111.28 N/mm2, Rp1.0t2= 136.60 N/mm2, fh2= 91.07 N/mm2

POINT DATA:

F13, Coordinates, X= 0.00 mm, Y= 580.00 mm, Z= 2799.00 mm
F13, Joint End Type= Socket welded, SIFI= 2.10, SIFO= 2.10, Override all other values= Yes

From F03 to F04, DY= 63.50 mm Run

POINT DATA:

F03, Coordinates, X= 0.00 mm, Y= 1796.80 mm, Z= 2799.00 mm

From F04 to F05, DY= 63.50 mm Tee

□

CIRCUITOPROVABARRE

07/30/2010 CIRCUITO PROVA BARRE
BENTLEY

02:16 PM

AutoPIPE Plus 9.2.1 MODEL PAGE 12

C O M P O N E N T D A T A L I S T I N G

COMPONENT DATA (Tee Header, Center= F04):
B16.9 welding tee, SIFI= 1.00, SIFO= 1.00

POINT DATA:

F04, Coordinates, X= 0.00 mm, Y= 1860.30 mm, Z= 2799.00 mm

F04, Joint End Type= Socket welded, SIFI= 2.10, SIFO= 2.10, override all
other values= Yes

From F05 to F06, DY= 76.20 mm

Run

POINT DATA:

F05, Coordinates, X= 0.00 mm, Y= 1923.80 mm, Z= 2799.00 mm

From F06 to F07, DZ= 76.20 mm

Bend

COMPONENT DATA (Bend, TIP= F06, Near= F06 N, Mid= F06 M, Far= F06 F):
Long Elbow, Radius= 76.20 mm, Bend angle= 90.00 deg, Mid point at 50.00
percent, End flanges= 0, Flex= Auto, SIFI= 1.00,
SIFO= 1.00

POINT DATA:

F06, Coordinates, X= 0.00 mm, Y= 2000.00 mm, Z= 2799.00 mm

F06 N, Coordinates, X= 0.00 mm, Y= 1924.44 mm, Z= 2799.00 mm

F06 M, Coordinates, X= 0.00 mm, Y= 1977.68 mm, Z= 2821.32 mm

F06 F, Coordinates, X= 0.00 mm, Y= 2000.00 mm, Z= 2874.56 mm

From F07 to F08, DZ= 136.00 mm

Run

POINT DATA:

F07, Coordinates, X= 0.00 mm, Y= 2000.00 mm, Z= 2875.20 mm

From F08 to F09, DZ= 450.85 mm

Valv

COMPONENT DATA (Valve):
GATE-F, Rating= 2500, Length= 450.85 mm, Valve weight = 70 kg, surface
factor= 0.00, End type= weld neck, SIF= 1.00

POINT DATA:

F08, Coordinates, X= 0.00 mm, Y= 2000.00 mm, Z= 3011.20 mm

F08, Flange= WELDNECK, Rating= 2500, Flange weight= 19.10 kg, Bolt/Nut
Weight= 0.00 kg, End type= weld neck, SIF= 1.00,
Perform ANSI check= No

F08 M, Coordinates, X= 0.00 mm, Y= 2000.00 mm, Z= 3236.62 mm

From F09 to F16, DZ= 836.95 mm

Run

POINT DATA:

circuitoprovabarre.txt

F09, Coordinates, X= 0.00 mm, Y= 2000.00 mm, Z= 3462.05 mm
F09, Flange= WELDNECK, Rating= 2500, Flange weight= 19.10 kg, Bolt/Nut
Weight= 0.00 kg, End type= weld neck, SIF= 1.00,
Perform ANSI check= No

From F16 to F10, DZ= 541.05 mm

Run

□

CIRCUITOPROVABARRE

07/30/2010 CIRCUITO PROVA BARRE
BENTLEY

02:16 PM

AutoPIPE Plus 9.2.1 MODEL PAGE 13

C O M P O N E N T D A T A L I S T I N G

POINT DATA:

F16, Coordinates, X= 0.00 mm, Y= 2000.00 mm, Z= 4299.00 mm

SUPPORT DATA:

F16, Guide, Support Id= F16 1, Connected to Ground, Stiffness= RIGID

From F10 to F11, DZ= 1321.00 mm

Run

POINT DATA:

F10, Coordinates, X= 0.00 mm, Y= 2000.00 mm, Z= 4840.05 mm

F10, Flange= WELDNECK, Rating= 2500, Flange weight= 19.10 kg, Bolt/Nut
Weight= 0.00 kg, End type= weld neck, SIF= 1.00,
Perform ANSI check= No

F10, Flange= WELDNECK, Rating= 2500, Flange weight= 19.10 kg, Bolt/Nut
Weight= 0.00 kg, End type= weld neck, SIF= 1.00,
Perform ANSI check= No

From F11 to A13, DZ= 4572.95 mm

Run

POINT DATA:

F11, Coordinates, X= 0.00 mm, Y= 2000.00 mm, Z= 6161.05 mm

F11, Flange= WELDNECK, Rating= 2500, Flange weight= 19.10 kg, Bolt/Nut
Weight= 0.00 kg, End type= weld neck, SIF= 1.00,
Perform ANSI check= No

F11, Flange= WELDNECK, Rating= 2500, Flange weight= 19.10 kg, Bolt/Nut
Weight= 0.00 kg, End type= weld neck, SIF= 1.00,
Perform ANSI check= No

F11, Added weight= 227.00 kg

F11, Added weight= 60.00 kg, DX= 465.50 mm

A13, Coordinates, X= 0.00 mm, Y= 2000.00 mm, Z= 10734.00 mm

*** SEGMENT G

From F04 to G01, DZ= -62.50 mm

Tee

COMPONENT DATA (Tee Branch, Center= F04):

B16.9 welding tee, SIFI= 1.00, SIFO= 1.00

PIPE DATA:

circuitoprovabarre.txt

Pipe Id= 0.5INS16, Composition= Austentic Stainless, Nom Size= 15 mm, OD= 21.336 mm, wall Thk= 4.775 mm, Mill= 0.597 mm, Content Sp Gr= 1.000, Content Unit wgt= 1.07 N/m, Insul Thk= 0 mm, Insul Material= OTHER

POINT DATA:

F04, Coordinates, X= 0.00 mm, Y= 1860.30 mm, Z= 2799.00 mm
F04, Joint End Type= Socket welded, SIFI= 2.10, SIFO= 2.10, Override all other values= Yes
G01, Coordinates, X= 0.00 mm, Y= 1860.30 mm, Z= 2736.50 mm

*** SEGMENT H

From F13 to H01, DZ= -350.00 mm Tee

□

CIRCUITOPROVABARRE

07/30/2010 CIRCUITO PROVA BARRE
BENTLEY

02:16 PM

AutoPIPE Plus 9.2.1 MODEL PAGE 14

C O M P O N E N T D A T A L I S T I N G

COMPONENT DATA (Tee Branch, Center= F13):

B16.9 welding tee, SIFI= 1.00, SIFO= 1.00

PIPE DATA:

Pipe Id= 3/8S80, Composition= Austentic Stainless, Nom Size= 10 mm, OD= 17.145 mm, Sch= 80, wall Thk= 3.200 mm, Mill= 0.400 mm, Content Sp Gr= 1.000, Content Unit wgt= 0.89 N/m

OPERATING DATA (F13 to H01 N):

T2= 40.00 deg C, Exp2= 0.30880 mm/m, E2= 0.19827 E6 N/mm2, Rp0.2t2= 195.00 N/mm2, Rp1.0t2= 230.00 N/mm2, fh2= 153.33 N/mm2

POINT DATA:

F13, Coordinates, X= 0.00 mm, Y= 580.00 mm, Z= 2799.00 mm
F13, Joint End Type= Socket welded, SIFI= 2.10, SIFO= 2.10, Override all other values= Yes

From H01 to H02, DY= 2018.00 mm

Bend

COMPONENT DATA (Bend, TIP= H01, Near= H01 N, Mid= H01 M, Far= H01 F):

Long Elbow, Radius= 14.29 mm, Bend angle= 90.00 deg, Mid point at 50.00 percent, End flanges= 0, Flex= Auto, SIFI= 1.00, SIFO= 1.00

OPERATING DATA:

T1= 20.00 deg C, Exp1= 0 mm/m, E1= 0.19996 E6 N/mm2, Rp0.2t1= 195.00 N/mm2, Rp1.0t1= 230.00 N/mm2, fh1= 153.33 N/mm2

POINT DATA:

H01, Coordinates, X= 0.00 mm, Y= 580.00 mm, Z= 2449.00 mm
H01 N, Coordinates, X= 0.00 mm, Y= 580.00 mm, Z= 2463.29 mm
H01 M, Coordinates, X= 0.00 mm, Y= 584.18 mm, Z= 2453.18 mm
H01 F, Coordinates, X= 0.00 mm, Y= 594.29 mm, Z= 2449.00 mm

circuitoprovabarre.txt

From H02 to H03, DY= 13.50 mm Run

POINT DATA:

H02, Coordinates, X= 0.00 mm, Y= 2598.00 mm, Z= 2449.00 mm

From H03 to H04, DY= 13.50 mm Tee

COMPONENT DATA (Tee Header, Center= H03):

B16.9 welding tee, SIFI= 1.00, SIFO= 1.00

POINT DATA:

H03, Coordinates, X= 0.00 mm, Y= 2611.50 mm, Z= 2449.00 mm

H03, Joint End Type= Socket welded, SIFI= 2.10, SIFO= 2.10, override all other values= Yes

From H04 to H12, DY= 77.49 mm Run

POINT DATA:

H04, Coordinates, X= 0.00 mm, Y= 2625.00 mm, Z= 2449.00 mm

From H12 to H05, DY= 77.49 mm Run

□

CIRCUITOPROVABARRE

07/30/2010 CIRCUITO PROVA BARRE

BENTLEY

02:16 PM

AutoPIPE Plus 9.2.1 MODEL PAGE 15

C O M P O N E N T D A T A L I S T I N G

POINT DATA:

H12, Coordinates, X= 0.00 mm, Y= 2702.49 mm, Z= 2449.00 mm

From H05 to H06, DZ= 625.55 mm Bend

COMPONENT DATA (Bend, TIP= H05, Near= H05 N, Mid= H05 M, Far= H05 F):

Long Elbow, Radius= 14.29 mm, Bend angle= 90.00 deg, Mid point at 50.00 percent, End flanges= 0, Flex= Auto, SIFI= 1.00, SIFO= 1.00

POINT DATA:

H05, Coordinates, X= 0.00 mm, Y= 2779.98 mm, Z= 2449.00 mm

H05 N, Coordinates, X= 0.00 mm, Y= 2765.69 mm, Z= 2449.00 mm

H05 M, Coordinates, X= 0.00 mm, Y= 2775.80 mm, Z= 2453.18 mm

H05 F, Coordinates, X= 0.00 mm, Y= 2779.98 mm, Z= 2463.29 mm

From H06 to H07, DZ= 50.80 mm Redu

COMPONENT DATA (Reducer):

Length= 50.80 mm, SIF= 2.00

POINT DATA:

H06, Coordinates, X= 0.00 mm, Y= 2779.98 mm, Z= 3074.55 mm

circuitoprovabarre.txt

H06, Joint End Type= SW/no undercut, SIFI= 1.30, SIFO= 1.30, Override all other values= No

From H07 to H08, DZ= 75.00 mm Run

PIPE DATA:

Pipe Id= 1INS80, Composition= Austentic Stainless, Nom Size= 25 mm, OD= 33.401 mm, Wall Thk= 4.547 mm, Mill= 0.568 mm, Content Sp Gr= 1.000, Content Unit wgt= 4.55 N/m

POINT DATA:

H07, Coordinates, X= 0.00 mm, Y= 2779.98 mm, Z= 3125.35 mm

From H08 to H09, DZ= 254.00 mm valv

COMPONENT DATA (Valve):

GLOBE-F, Rating= Non-standard, Length= 254.00 mm, Valve weight = 30 kg, Actuator Auto = No, Actuator Symbol = Yes, Actuator weight = 40 kg, Actuator DX = 0.00 mm, DY = -300.00 mm, DZ = 0.00 mm, Surface factor= 0.00, End type= weld neck, SIF= 1.00

POINT DATA:

H08, Coordinates, X= 0.00 mm, Y= 2779.98 mm, Z= 3200.35 mm
H08, Flange= WELDNECK, Rating= 1500, Flange weight= 4.10 kg, Bolt/Nut weight= 0.00 kg, End type= weld neck, SIF= 1.00, Perform ANSI check= No
H08 M, Coordinates, X= 0.00 mm, Y= 2779.98 mm, Z= 3327.35 mm

SUPPORT DATA:

H08 M, Variable Spring Hanger, Support Id= H08 M1, Connected to Ground, 1 hanger(s), Stiffness= 11 N/mm, Preload= 1041 N

From H09 to H17, DZ= 3483.60 mm Run

□

CIRCUITOPROVABARRE

07/30/2010 CIRCUITO PROVA BARRE
BENTLEY

02:16 PM

AutoPIPE Plus 9.2.1 MODEL PAGE 16

C O M P O N E N T D A T A L I S T I N G

POINT DATA:

H09, Coordinates, X= 0.00 mm, Y= 2779.98 mm, Z= 3454.35 mm
H09, Flange= WELDNECK, Rating= 1500, Flange weight= 4.10 kg, Bolt/Nut weight= 0.00 kg, End type= weld neck, SIF= 1.00, Perform ANSI check= No

From H17 to H10, DZ= 349.40 mm Run

POINT DATA:

H17, Coordinates, X= 0.00 mm, Y= 2779.98 mm, Z= 6937.95 mm

SUPPORT DATA:

H17, Guide, Support Id= H17 1, Connected to Ground, Stiffness= RIGID

circuitoprovabarre.txt

From H10 to H20, DZ= 3396.42 mm Run

OPERATING DATA:

T2= 330.00 deg C, Exp2= 5.38910 mm/m, E2= 0.17368 E6 N/mm2, Rp0.2t2= 106.40 N/mm2, Rp1.0t2= 131.40 N/mm2, fh2= 87.60 N/mm2

POINT DATA:

H10, Coordinates, X= 0.00 mm, Y= 2779.98 mm, Z= 7287.35 mm
H10, Flange= WELDNECK, Rating= 2500, Flange weight= 5.90 kg, Bolt/Nut weight= 0.00 kg, End type= weld neck, SIF= 1.00, Perform ANSI check= No
H10, Flange= WELDNECK, Rating= 2500, Flange weight= 5.90 kg, Bolt/Nut weight= 0.00 kg, End type= weld neck, SIF= 1.00, Perform ANSI check= No
H10, Added weight= 60.00 kg

From H20 to D07, DY= 0.53 mm, DZ= 106.63 mm, L= 106.63 mm Run

POINT DATA:

H20, Coordinates, X= 0.00 mm, Y= 2779.98 mm, Z= 10683.77 mm
D07, Coordinates, X= 0.00 mm, Y= 2780.51 mm, Z= 10790.40 mm

SUPPORT DATA:

H20, Anchor, KTX= Free, KTY= Free, KTZ= Rigid, KRX= Free, KRY= Free, KRZ= Free

*** SEGMENT I

From H03 to I02, DZ= -125.00 mm Tee

COMPONENT DATA (Tee Branch, Center= H03):

B16.9 welding tee, SIFI= 1.00, SIFO= 1.00

PIPE DATA:

Pipe Id= 3/8S80, Composition= Austentic Stainless, Nom Size= 10 mm, OD= 17.145 mm, wall Thk= 3.200 mm, Mill= 0.400 mm, Content Sp Gr= 1.000, Content Unit wgt= 0.89 N/m

OPERATING DATA:

T2= 40.00 deg C, Exp2= 0.30880 mm/m, E2= 0.19827 E6 N/mm2, Rp0.2t2= 195.00 N/mm2, Rp1.0t2= 230.00 N/mm2, fh2= 153.33 N/mm2

□

CIRCUITOPROVABARRE

07/30/2010 CIRCUITO PROVA BARRE
BENTLEY

02:16 PM

AutoPIPE Plus 9.2.1 MODEL PAGE 17

C O M P O N E N T D A T A L I S T I N G

POINT DATA:

H03, Coordinates, X= 0.00 mm, Y= 2611.50 mm, Z= 2449.00 mm
H03, Joint End Type= Socket welded, SIFI= 2.10, SIFO= 2.10, override all other values= Yes

circuitoprovabarre.txt

From I02 to I01, DZ= 111.50 mm Run

POINT DATA:

I02, Coordinates, X= 0.00 mm, Y= 2611.50 mm, Z= 2324.00 mm
I01, Coordinates, X= 0.00 mm, Y= 2611.50 mm, Z= 2435.50 mm

*** SEGMENT J

From B05 to J01, DY= 465.00 mm Tee

COMPONENT DATA (Tee Branch, Center= B05):

B16.9 welding tee, SIFI= 1.00, SIFO= 1.00

PIPE DATA:

Pipe Id= 1INS80, Composition= Austentic Stainless, Nom Size= 25 mm, OD= 33.401 mm, wall Thk= 4.547 mm, Mill= 0.568 mm, Content Sp Gr= 1.000, Content Unit wgt= 4.55 N/m

OPERATING DATA:

T1= 354.00 deg C, T2= 354.00 deg C, T3= 152.00 deg C, Exp1= 5.85176 mm/m, Exp2= 5.85176 mm/m, Exp3= 2.14622 mm/m, E1= 0.17164 E6 N/mm2, E2= 0.17164 E6 N/mm2, E3= 0.18877 E6 N/mm2, Rp0.2t1= 103.52 N/mm2, Rp0.2t2= 103.52 N/mm2, Rp0.2t3= 139.48 N/mm2, Rp1.0t1= 128.68 N/mm2, Rp1.0t2= 128.68 N/mm2, Rp1.0t3= 169.40 N/mm2, fh1= 85.79 N/mm2, fh2= 85.79 N/mm2, fh3= 112.93 N/mm2

POINT DATA:

B05, Coordinates, X= 0.00 mm, Y= 139.70 mm, Z= 15727.08 mm
B05, Joint End Type= Socket welded, SIFI= 2.10, SIFO= 2.10, override all other values= Yes

From J01 to J02, DY= 38.10 mm Run

POINT DATA:

J01, Coordinates, X= 0.00 mm, Y= 604.70 mm, Z= 15727.08 mm

From J02 to J03, DZ= 38.10 mm Bend

COMPONENT DATA (Bend, TIP= J02, Near= J02 N, Far= J02 F):

Long Elbow, Radius= 38.10 mm, Bend angle= 90.00 deg, End flanges= 0, Flex= Auto, SIFI= 1.02, SIFO= 1.02

POINT DATA:

J02, Coordinates, X= 0.00 mm, Y= 642.80 mm, Z= 15727.08 mm
J02 N, Coordinates, X= 0.00 mm, Y= 605.33 mm, Z= 15727.08 mm
J02 F, Coordinates, X= 0.00 mm, Y= 642.80 mm, Z= 15764.54 mm

From J03 to J04, DZ= 241.00 mm Run

□

CIRCUITOPROVABARRE

07/30/2010 CIRCUITO PROVA BARRE
BENTLEY

02:16 PM

AutoPIPE Plus 9.2.1 MODEL PAGE 18

circuitoprovabarre.txt

C O M P O N E N T D A T A L I S T I N G

POINT DATA:

J03, Coordinates, X= 0.00 mm, Y= 642.80 mm, Z= 15765.18 mm
J04, Coordinates, X= 0.00 mm, Y= 642.80 mm, Z= 16006.18 mm
J04, Flange= WELDNECK, Rating= 2500, Flange Weight= 5.90 kg, Bolt/Nut weight=
0.00 kg, End type= weld neck, SIF= 1.00,
Perform ANSI check= No
J04, Flange= WELDNECK, Rating= 2500, Flange Weight= 5.90 kg, Bolt/Nut weight=
0.00 kg, End type= weld neck, SIF= 1.00,
Perform ANSI check= No

*** SEGMENT K

From D03 to K01, DZ= 165.00 mm

Tee

COMPONENT DATA (Tee Branch, Center= D03):

B16.9 welding tee, SIFI= 1.00, SIFO= 1.00

PIPE DATA:

Pipe Id= 0.5INS80, Composition= Austentic Stainless, Nom Size= 15 mm, OD=
21.336 mm, wall Thk= 3.734 mm, Mill= 0.467 mm,
Content Sp Gr= 1.000, Content Unit wgt= 1.48 N/m

OPERATING DATA:

T1= 20.00 deg C, T2= 330.00 deg C, T3= 120.00 deg C, Exp1= 0 mm/m, Exp2=
5.38910 mm/m, Exp3= 1.60340 mm/m,
E1= 0.19996 E6 N/mm2, E2= 0.17368 E6 N/mm2, E3= 0.19148 E6 N/mm2, Rp0.2t1=
195.00 N/mm2, Rp0.2t2= 106.40 N/mm2,
Rp0.2t3= 149.00 N/mm2, Rp1.0t1= 230.00 N/mm2, Rp1.0t2= 131.40 N/mm2, Rp1.0t3=
182.00 N/mm2, fh1= 153.33 N/mm2,
fh2= 87.60 N/mm2, fh3= 121.33 N/mm2

POINT DATA:

D03, Coordinates, X= 0.00 mm, Y= 2704.31 mm, Z= 10924.50 mm
D03, Joint End Type= Socket welded, SIFI= 2.10, SIFO= 2.10, Override all
other values= Yes
K01, Coordinates, X= 0.00 mm, Y= 2704.31 mm, Z= 11089.50 mm

Number of points in the system: 108

Weight of Empty Pipes + Weight of Contents = Total weight of System
1395.1 kg + 47.0 kg = 1442.2 kg

□

CIRCUITOPROVABARRE

07/30/2010 CIRCUITO PROVA BARRE
BENTLEY

02:16 PM

AutoPIPE Plus 9.2.1 MODEL PAGE 19

C O O R D I N A T E S D A T A L I S T I N G

circuitoprovabarre.txt

POINT -----COORDINATE (mm)-----

NAME X Y Z

*** SEGMENT A

A20	0.00	0.00	1200.00
A19	0.00	0.00	1649.00
A18	0.00	0.00	2098.00
A17	0.00	0.00	2735.50
A15	0.00	0.00	2799.00
A16	0.00	0.00	2862.50
A22	0.00	0.00	4362.50
A14	0.00	0.00	8334.00
A04	0.00	0.00	10780.00
A03 N	0.00	0.00	10988.00
A03	0.00	0.00	11064.20
A03 M	0.00	22.22	11041.79
A03 F	0.00	75.56	11064.20
A00	0.00	76.20	11064.20
A25	0.00	102.00	11064.20
A01	0.00	139.70	11064.20
A05	0.00	1796.80	11064.20
A07	0.00	1860.30	11064.20
A26	0.00	1898.00	11064.20
A08	0.00	1923.80	11064.20
A09 N	0.00	1924.44	11064.20
A09	0.00	2000.00	11064.20
A09 M	0.00	1977.68	11041.88
A09 F	0.00	2000.00	10988.63
A11	0.00	2000.00	10988.00
A10	0.00	2000.00	10924.50
A12	0.00	2000.00	10861.00
A13	0.00	2000.00	10734.00

*** SEGMENT B

A01	0.00	139.70	11064.20
B01	0.00	139.70	11186.40
B02	0.00	139.70	11276.40
B03	0.00	139.70	11340.40
B04	0.00	139.70	11429.40
B09	0.00	139.70	12045.40
B05	0.00	139.70	15727.08
B10	0.00	139.70	15793.24
B06	0.00	139.70	15859.40
B07	0.00	139.70	15948.40
B08	0.00	139.70	16234.90

*** SEGMENT C

A07	0.00	1860.30	11064.20
C01	0.00	1860.30	11233.70

*** SEGMENT D

A10	0.00	2000.00	10924.50
D01	0.00	2050.80	10924.50
D08	0.00	2100.80	10924.50
D02	0.00	2666.21	10924.50

□

CIRCUITOPROVABARRE

07/30/2010 CIRCUITO PROVA BARRE
BENTLEY

C O O R D I N A T E S D A T A L I S T I N G

POINT -----COORDINATE (mm)-----

NAME X Y Z

D03	0.00	2704.31	10924.50
D04	0.00	2742.41	10924.50
D05 N	0.00	2743.04	10924.50
D05	0.00	2780.51	10924.50
D05 M	0.00	2769.35	10913.34
D05 F	0.00	2780.51	10887.03
D06	0.00	2780.51	10886.40
D07	0.00	2780.51	10790.40

*** SEGMENT F

A15	0.00	0.00	2799.00
F01	0.00	63.50	2799.00
F02	0.00	304.00	2799.00
F13	0.00	580.00	2799.00
F03	0.00	1796.80	2799.00
F04	0.00	1860.30	2799.00
F05	0.00	1923.80	2799.00
F06 N	0.00	1924.44	2799.00
F06	0.00	2000.00	2799.00
F06 M	0.00	1977.68	2821.32
F06 F	0.00	2000.00	2874.56
F07	0.00	2000.00	2875.20
F08	0.00	2000.00	3011.20
F08 M	0.00	2000.00	3236.62
F09	0.00	2000.00	3462.05
F16	0.00	2000.00	4299.00
F10	0.00	2000.00	4840.05
F11	0.00	2000.00	6161.05
A13	0.00	2000.00	10734.00

*** SEGMENT G

F04	0.00	1860.30	2799.00
G01	0.00	1860.30	2736.50

*** SEGMENT H

F13	0.00	580.00	2799.00
H01 N	0.00	580.00	2463.29
H01	0.00	580.00	2449.00
H01 M	0.00	584.18	2453.18
H01 F	0.00	594.29	2449.00
H02	0.00	2598.00	2449.00
H03	0.00	2611.50	2449.00
H04	0.00	2625.00	2449.00
H12	0.00	2702.49	2449.00
H05 N	0.00	2765.69	2449.00
H05	0.00	2779.98	2449.00
H05 M	0.00	2775.80	2453.18
H05 F	0.00	2779.98	2463.29
H06	0.00	2779.98	3074.55
H07	0.00	2779.98	3125.35
H08	0.00	2779.98	3200.35
H08 M	0.00	2779.98	3327.35

□

CIRCUITOPROVABARRE

07/30/2010 CIRCUITO PROVA BARRE
BENTLEY

02:16 PM

AutoPIPE Plus 9.2.1 MODEL PAGE 21

C O O R D I N A T E S D A T A L I S T I N G

POINT -----COORDINATE (mm)-----

NAME X Y Z

POINT NAME	X	Y	Z
H09	0.00	2779.98	3454.35
H17	0.00	2779.98	6937.95
H10	0.00	2779.98	7287.35
H20	0.00	2779.98	10683.77
D07	0.00	2780.51	10790.40

*** SEGMENT I

H03	0.00	2611.50	2449.00
I02	0.00	2611.50	2324.00
I01	0.00	2611.50	2435.50

*** SEGMENT J

B05	0.00	139.70	15727.08
J01	0.00	604.70	15727.08
J02 N	0.00	605.33	15727.08
J02	0.00	642.80	15727.08
J02 F	0.00	642.80	15764.54
J03	0.00	642.80	15765.18
J04	0.00	642.80	16006.18

*** SEGMENT K

D03	0.00	2704.31	10924.50
K01	0.00	2704.31	11089.50

□

CIRCUITOPROVABARRE

07/30/2010 CIRCUITO PROVA BARRE
BENTLEY

02:16 PM

AutoPIPE Plus 9.2.1 MODEL PAGE 22

P I P E D A T A L I S T I N G

Pipe ID/ Composition Material	Nom/ Sch	O.D. mm	-----Thickness(mm)----- w.Th. Corr Mill	Insu	Ling	Spec Grav	weight(N/m) Pipe Other Total	ZL/ ZC
2SCH160 Austentic Stainless	50	60.325	8.738	0	1.09	40	0 1.00 110 16.83 141	1.00

circuitoprovabarre.txt

1.4301	160											1.00
3/4S160	20	26.670	5.563	0	0.69	40	0	1.00	28.69	11.19	41.73	1.00
Austentic Stainless												
1.4301	160											1.00
0.5INS16	15	21.336	4.775	0	0.60	0	0	1.00	19.32	0	20.39	1.00
Austentic Stainless												
1.4301	160											1.00
1INS80	25	33.401	4.547	0	0.57	0	0	1.00	32.05	0	36.60	1.00
Austentic Stainless												
1.4301	80											1.00
0.5INS80	15	21.336	3.734	0	0.47	0	0	1.00	16.06	0	17.54	1.00
Austentic Stainless												
1.4301	80											1.00
3/8S80	10	17.145	3.200	0	0.40	0	0	1.00	10.90	0	11.79	1.00
Austentic Stainless												
1.4301	80											1.00
2INCUST	1600	63.000	10.50	0	1.31	0	0	1.00	135	0	148	1.00
Austentic Stainless												
1.4301	NS											1.00
1.5Is160	40	48.260	7.137	0	0.89	40	0	1.00	71.71	14.81	95.41	1.00
Austentic Stainless												
1.4301	160											1.00
2.5Is160	65	73.025	9.525	0	1.19	40	0	1.00	148	18.96	189	1.00
Austentic Stainless												
1.4301	160											1.00
TENUTAIN	1600	63.000	10.50	0	1.31	40	0	1.00	135	17.28	166	1.00
Austentic Stainless												
1.4301	NS											1.00

□

CIRCUITOPROVABARRE

07/30/2010 CIRCUITO PROVA BARRE
BENTLEY

02:16 PM

AutoPIPE Plus 9.2.1 MODEL PAGE 23

M A T E R I A L D A T A L I S T I N G

Material Composition Name/[Comp.]	Pipe ID	Density kg/m3	Pois. Al/At	Temper. deg C	Modulus E6 N/mm2 Axial	Modulus E6 N/mm2 Hoop	Modulus E6 N/mm2 Shear	Expans. mm/m
1.4301 Austentic Stainless X5CRNI18-10 [Austenitic]	TENUTAIN	7930.0	0.30	20.0	0.19996	0.19996	0.07691	
			40.00	330.0	0.17368			5.3891
			35.00	120.0	0.19148			1.6034
1.4301 Austentic Stainless X5CRNI18-10	2SCH160	7930.0	0.30	20.0	0.19996	0.19996	0.07691	
			40.00	330.0	0.17368			5.3891

circuitoprovabarre.txt

[Austenitic]		35.00	120.0	0.19148				1.6034
			292.0	0.17690				4.6680
			40.0	0.19827				0.3088
1.4301	3/4s160	7930.0	0.30	20.0	0.19996	0.19996	0.07691	
Austentic Stainless	X5CRNI18-10			40.00	354.0	0.17164		5.8518
[Austenitic]				35.00	152.0	0.18877		2.1462
1.4301	1.5Is160	7930.0	0.30	20.0	0.19996	0.19996	0.07691	
Austentic Stainless	X5CRNI18-10			40.00	354.0	0.17164		5.8518
[Austenitic]				35.00	152.0	0.18877		2.1462
1.4301	2.5Is160	7930.0	0.30	20.0	0.19996	0.19996	0.07691	
Austentic Stainless	X5CRNI18-10			40.00	354.0	0.17164		5.8518
[Austenitic]				35.00	152.0	0.18877		2.1462
1.4301	1INS80	7930.0	0.30	20.0	0.19996	0.19996	0.07691	
Austentic Stainless	X5CRNI18-10			40.00	354.0	0.17164		5.8518
[Austenitic]				35.00	152.0	0.18877		2.1462
					330.0	0.17368		5.3891
					120.0	0.19148		1.6034
					40.0	0.19827		0.3088
1.4301	0.5INS16	7930.0	0.30	20.0	0.19996	0.19996	0.07691	
Austentic Stainless	X5CRNI18-10			40.00	330.0	0.17368		5.3891
[Austenitic]				35.00	152.0	0.18877		2.1462
					354.0	0.17164		5.8518
					120.0	0.19148		1.6034
					292.0	0.17690		4.6680
1.4301	3/8s80	7930.0	0.30	20.0	0.19996	0.19996	0.07691	
Austentic Stainless	X5CRNI18-10			40.00	292.0	0.17690		4.6680
[Austenitic]				35.00	40.0	0.19827		0.3088
					120.0	0.19148		1.6034
					354.0	0.17164		5.8518
1.4301	0.5INS80	7930.0	0.30	20.0	0.19996	0.19996	0.07691	
Austentic Stainless	X5CRNI18-10			40.00	330.0	0.17368		5.3891
[Austenitic]				35.00	120.0	0.19148		1.6034

□

CIRCUITOPROVABARRE

07/30/2010 CIRCUITO PROVA BARRE
BENTLEY

02:16 PM

AutoPIPE Plus 9.2.1 MODEL PAGE 24

M A T E R I A L A L L O W A B L E D A T A L I S T I N G

Material	Temper.	Proof (Rp0.2)	Proof (Rp1.0)	Tensile (Rmt)	Rupture (fcr)	Allow. (fh)
Name	Pipe ID	deg C	N/mm2	N/mm2	N/mm2	N/mm2

circuitoprovabarre.txt

X5CRNI18-10							
1.4301	TENUTAIN	20.0	195.00	230.00	500.00	0.00	166.67
		330.0	106.40	131.40	0.00	0.00	87.60
		120.0	149.00	182.00	0.00	0.00	121.33
X5CRNI18-10							
1.4301	2SCH160	20.0	195.00	230.00	500.00	0.00	166.67
		330.0	106.40	131.40	0.00	0.00	87.60
		120.0	149.00	182.00	0.00	0.00	121.33
		292.0	111.28	136.60	0.00	0.00	91.07
		40.0	195.00	230.00	0.00	0.00	153.33
X5CRNI18-10							
1.4301	3/4S160	20.0	195.00	230.00	500.00	0.00	166.67
		354.0	103.52	128.68	0.00	0.00	85.79
		152.0	139.48	169.40	0.00	0.00	112.93
X5CRNI18-10							
1.4301	1.5IS160	20.0	195.00	230.00	500.00	0.00	166.67
		354.0	103.52	128.68	0.00	0.00	85.79
		152.0	139.48	169.40	0.00	0.00	112.93
X5CRNI18-10							
1.4301	2.5IS160	20.0	195.00	230.00	500.00	0.00	166.67
		354.0	103.52	128.68	0.00	0.00	85.79
		152.0	139.48	169.40	0.00	0.00	112.93
X5CRNI18-10							
1.4301	1INS80	20.0	195.00	230.00	500.00	0.00	166.67
		354.0	103.52	128.68	0.00	0.00	85.79
		152.0	139.48	169.40	0.00	0.00	112.93
		330.0	106.40	131.40	0.00	0.00	87.60
		120.0	149.00	182.00	0.00	0.00	121.33
		20.0	195.00	230.00	0.00	0.00	153.33
		40.0	195.00	230.00	0.00	0.00	153.33
X5CRNI18-10							
1.4301	0.5INS16	20.0	195.00	230.00	500.00	0.00	166.67
		330.0	106.40	131.40	0.00	0.00	87.60
		152.0	139.48	169.40	0.00	0.00	112.93
		354.0	103.52	128.68	0.00	0.00	85.79
		120.0	149.00	182.00	0.00	0.00	121.33
		292.0	111.28	136.60	0.00	0.00	91.07
X5CRNI18-10							
1.4301	3/8S80	20.0	195.00	230.00	500.00	0.00	166.67
		292.0	111.28	136.60	0.00	0.00	91.07
		40.0	195.00	230.00	0.00	0.00	153.33
		120.0	149.00	182.00	0.00	0.00	121.33
		20.0	195.00	230.00	0.00	0.00	153.33
		354.0	103.52	128.68	0.00	0.00	85.79
X5CRNI18-10							
1.4301	0.5INS80	20.0	195.00	230.00	500.00	0.00	166.67
		20.0	195.00	230.00	0.00	0.00	153.33
		330.0	106.40	131.40	0.00	0.00	87.60
		120.0	149.00	182.00	0.00	0.00	121.33

□

CIRCUITOPROVABARRE

07/30/2010 CIRCUITO PROVA BARRE
BENTLEY

02:16 PM

AutoPIPE Plus 9.2.1 MODEL PAGE 25

FRAME POINT DATA LISTING

POINT NAME	COORDINATE(mm)			DATA TYPE	DESCRIPTION
	X	Y	Z		
H08 M	0.00	2779.98	3327.35		
H08 D	0.00	2479.98	3327.35		

CIRCUITOPROVABARRE

07/30/2010 CIRCUITO PROVA BARRE
BENTLEY

02:16 PM

AutoPIPE Plus 9.2.1 MODEL PAGE 26

BEAM DATA LISTING

(Length - mm , Rigid End - mm , Beta Angle - deg)

BEAM ID	POINT NAME	SEC. ID/ SEC. NAME	LENGTH	BETA ANGLE	RIGID END	RELEASE		
						Ax	Y-Y	Z-Z
H08 M	From H08 M	0	300.00	0.00	0.00	N	N	N
	To H08 D	RIGID			0.00	N	N	N

CIRCUITOPROVABARRE

07/30/2010 CIRCUITO PROVA BARRE
BENTLEY

02:16 PM

AutoPIPE Plus 9.2.1 MODEL PAGE 27

CROSS SECTION LISTING

Section ID/	Length(mm)	Area(cm ²)	Inertia (mm ⁴)	
Section Type	Depth/OD	width	Thick	Fthk/spc
ID Shape Name/Mat1	CC	Axial	Y-Shear	Z-Shear
		Torsion	Y-Y Bend	Z-Z Bend
0 W RIGID RIGID	6.45	6.45	254.00	254.00
		6.45	41623140	41623140
			25.40	25.40
			41623140	41623140

circuitoprovabarre.txt

□

 CIRCUITOPROVABARRE

07/30/2010 CIRCUITO PROVA BARRE
 BENTLEY

02:16 PM

AutoPIPE Plus 9.2.1 MODEL PAGE 28

 BEAM MATERIAL LISTING

Elastic

modulus Poissons Density

MATERIAL ID E6 N/mm2 ratio kg/m3

 RIGID 68.948 0.300 0.00

□

 CIRCUITOPROVABARRE

07/30/2010 CIRCUITO PROVA BARRE
 BENTLEY

02:16 PM

AutoPIPE Plus 9.2.1 MODEL PAGE 29

 OPERATING TEMPERATURE AND PRESSURE DATA

STRESSES IN N/mm2

POINT	PRESS.	TEMPER	EXPAN.	MODULUS	0.2%	1.0%	TENSILE	CREEP	
NAME	CASE	N/mm2	deg C	mm/m	E6 N/mm	PROOF	PROOF	(Rmt)	(fcr)

*** SEGMENT A
 A20 T1 17.2500 330 5.389 0.17368 106.40 131.40 0.00 0.00u
 T2 10.0000 330 5.389 0.17368 106.40 131.40 0.00 0.00u
 T3 0.5000 120 1.603 0.19148 149.00 182.00 0.00 0.00u
 A13 Same as previous point.

*** SEGMENT B
 A01 T1 17.2500 354 5.852 0.17164 103.52 128.68 0.00 0.00u
 T2 10.0000 354 5.852 0.17164 103.52 128.68 0.00 0.00u
 T3 0.5000 152 2.146 0.18877 139.48 169.40 0.00 0.00u
 B08 Same as previous point.

*** SEGMENT C
 A07 T1 17.2500 330 5.389 0.17368 106.40 131.40 0.00 0.00u
 T2 10.0000 330 5.389 0.17368 106.40 131.40 0.00 0.00u
 T3 0.5000 152 2.146 0.18877 139.48 169.40 0.00 0.00u
 C01 Same as previous point.

circuitoprovabarre.txt

```

*** SEGMENT D
A10  T1  17.2500    330    5.389    0.17368  106.40  131.40    0.00    0.00u
      T2  10.0000    330    5.389    0.17368  106.40  131.40    0.00    0.00u
      T3   0.5000    120    1.603    0.19148  149.00  182.00    0.00    0.00u
D01  T1  17.2500   20.00    0.000    0.19996  195.00  230.00    0.00    0.00u
      T2  10.0000    330    5.389    0.17368  106.40  131.40    0.00    0.00u
      T3   0.5000    120    1.603    0.19148  149.00  182.00    0.00    0.00u
D07  Same as previous point.

*** SEGMENT F
A15  T1  17.2500    292    4.668    0.17690  111.28  136.60    0.00    0.00u
      T2  10.0000   40.00    0.309    0.19827  195.00  230.00    0.00    0.00u
      T3   0.5000    120    1.603    0.19148  149.00  182.00    0.00    0.00u
F13  T1  17.2500    292    4.668    0.17690  111.28  136.60    0.00    0.00u
      T2  10.0000    292    4.668    0.17690  111.28  136.60    0.00    0.00u
      T3   0.5000    120    1.603    0.19148  149.00  182.00    0.00    0.00u
A13  Same as previous point.

*** SEGMENT G
F04  T1  17.2500    292    4.668    0.17690  111.28  136.60    0.00    0.00u
      T2  10.0000    292    4.668    0.17690  111.28  136.60    0.00    0.00u
      T3   0.5000    120    1.603    0.19148  149.00  182.00    0.00    0.00u
G01  Same as previous point.

*** SEGMENT H
F13  T1  17.2500    292    4.668    0.17690  111.28  136.60    0.00    0.00u
      T2  10.0000   40.00    0.309    0.19827  195.00  230.00    0.00    0.00u
      T3   0.5000    120    1.603    0.19148  149.00  182.00    0.00    0.00u
H01  N T1  17.2500   20.00    0.000    0.19996  195.00  230.00    0.00    0.00u
      T2  10.0000   40.00    0.309    0.19827  195.00  230.00    0.00    0.00u
      T3   0.5000    120    1.603    0.19148  149.00  182.00    0.00    0.00u
H10  T1  17.2500   20.00    0.000    0.19996  195.00  230.00    0.00    0.00u
      T2  10.0000    330    5.389    0.17368  106.40  131.40    0.00    0.00u
      T3   0.5000    120    1.603    0.19148  149.00  182.00    0.00    0.00u
D07  Same as previous point.

*** SEGMENT I
H03  T1  17.2500   20.00    0.000    0.19996  195.00  230.00    0.00    0.00u
      T2  10.0000   40.00    0.309    0.19827  195.00  230.00    0.00    0.00u

```

□

CIRCUITOPROVABARRE

07/30/2010 CIRCUITO PROVA BARRE
BENTLEY

02:16 PM

AutoPIPE Plus 9.2.1 MODEL PAGE 30

OPERATING TEMPERATURE AND PRESSURE DATA

STRESSES IN N/mm2

POINT	PRESS.	TEMPER	EXPAN.	MODULUS	0.2%	1.0%	TENSILE	CREEP	
NAME	CASE	N/mm2	deg C	mm/m	E6 N/mm	PROOF	PROOF	(Rmt)	(fcr)
I01	T3	0.5000	120	1.603	0.19148	149.00	182.00	0.00	0.00u

*** SEGMENT J

```

circuitoprovabarre.txt
B05  T1  17.2500   354   5.852   0.17164  103.52  128.68   0.00   0.00u
      T2  10.0000   354   5.852   0.17164  103.52  128.68   0.00   0.00u
      T3   0.5000   152   2.146   0.18877  139.48  169.40   0.00   0.00u
J04  Same as previous point.

*** SEGMENT K
D03  T1  17.2500  20.00   0.000   0.19996  195.00  230.00   0.00   0.00u
      T2  10.0000   330   5.389   0.17368  106.40  131.40   0.00   0.00u
      T3   0.5000   120   1.603   0.19148  149.00  182.00   0.00   0.00u
K01  Same as previous point.

```

u User-defined value
* Non-code material for allowable stress;
Non-standard material for expansion and modulus

□

CIRCUITOPROVABARRE

07/30/2010 CIRCUITO PROVA BARRE
BENTLEY

02:16 PM

AutoPIPE Plus 9.2.1 MODEL PAGE 31

S U P P O R T D A T A L I S T I N G

Point Size Name	Support Figure Type	Support ID	Conn.to /Dir	Stiff.	Gap 1 (mm)	Gap 2 (mm)	Fric. Fact.	GapSet /#hgr	Preload (N)
-----------------	---------------------	------------	--------------	--------	------------	------------	-------------	--------------	-------------

Tag No.: <None>

A22	Guide-V	A22	1	Ground Rigid	0.0	0.0	0.00		
	Guide-H	A22	1	Ground Rigid	0.0	0.0	0.00		
Gap Dir.: (Gap1_V=-X, Gap2_V=+X, Gap1_H=-Y, Gap2_H=+Y)									

Tag No.: <None>

A25	Guide-V	A25	1	Ground Rigid	0.0	0.0	0.00		
	Guide-H	A25	1	Ground Rigid	0.0	0.0	0.00		

Tag No.: <None>

A26	Guide-V	A26	1	Ground Rigid	0.0	0.0	0.00		
	Guide-H	A26	1	Ground Rigid	0.0	0.0	0.00		

Tag No.: <None>

B09	Guide-V	B09	1	Ground Rigid	0.0	0.0	0.00		
	Guide-H	B09	1	Ground Rigid	0.0	0.0	0.00		
Gap Dir.: (Gap1_V=-X, Gap2_V=+X, Gap1_H=-Y, Gap2_H=+Y)									

Tag No.: <None>

F16	Guide-V	F16	1	Ground Rigid	0.0	0.0	0.00		
	Guide-H	F16	1	Ground Rigid	0.0	0.0	0.00		
Gap Dir.: (Gap1_V=-X, Gap2_V=+X, Gap1_H=-Y, Gap2_H=+Y)									

Tag No.: <None>

H08	M Spr. Hgr	H08	M1	Ground	11.030			1-Des	1041
-----	------------	-----	----	--------	--------	--	--	-------	------

Tag No.: <None>

H17	Guide-V	H17	1	Ground Rigid	0.0	0.0	0.00		
	Guide-H	H17	1	Ground Rigid	0.0	0.0	0.00		

circuitoprovabarre.txt
 Gap Dir.: (Gap1_V=-X, Gap2_V=+X, Gap1_H=-Y, Gap2_H=+Y)

Spring Manufacturer: Anvil/Grinnell

NOTE 1: No soil supports present in the system.

Gap 1 : V-stop,Guide-V=down, Linestop,Incline,Tie/link=backward, Guide-H=Left

Gap 2 : V-stop,Guide-V=Up , Linestop,Incline,Tie/link=forward , Guide-H=Right

Stiffness units for rotation support: N.m/deg , all others: N/mm

□

 CIRCUITOPROVABARRE

07/30/2010 CIRCUITO PROVA BARRE
 BENTLEY

02:16 PM

AutoPIPE Plus 9.2.1 MODEL PAGE 32

 B E N D D A T A L I S T I N G

Point Analysis Name	Bend Type (K)	Radius Flexibility (mm)	Angle Pressure (deg)	OD Case (mm)	tnom (mm)	Material	Flg/ Cuts	SIF in	SIF out	Set
A03	*Elbow 1.65	76L None	90.0	60.3	8.7	1.4301	0/0	1.00u	1.00u	1
A09	*Elbow 1.65	76L None	90.0	60.3	8.7	1.4301	0/0	1.00	1.00	1
D05	*Elbow 1.98	38L None	90.0	33.4	4.5	1.4301	0/0	1.02	1.02	1
F06	*Elbow 1.65	76L None	90.0	60.3	8.7	1.4301	0/0	1.00	1.00	1
H01	*Elbow 1.75	14L None	90.0	17.1	3.2	1.4301	0/0	1.00	1.00	1
H05	*Elbow 1.75	14L None	90.0	17.1	3.2	1.4301	0/0	1.00	1.00	1
J02	Elbow 1.98	38L None	90.0	33.4	4.5	1.4301	0/0	1.02	1.02	1

u = User SIF present at point, check user-sif data listing.

* = Mid-point present

L = Long radius

□

 CIRCUITOPROVABARRE

07/30/2010 CIRCUITO PROVA BARRE
 BENTLEY

02:16 PM

AutoPIPE Plus 9.2.1 MODEL PAGE 33

 T E E D A T A L I S T I N G

Point Name	Point Seg-Type	Pipe OD (mm)	Pipe Thk. (mm)	Material	Tee Type	**Crotch Radius (mm)	*Crotch Thick (mm)	SIF in	SIF out
---------------	-------------------	--------------------	----------------------	----------	-------------	----------------------------	--------------------------	-----------	------------

circuitoprovabarre.txt

ID	Header/Branch	Header Dim	Branch Dim	Header Dim	Branch Dim	Material	Header SIF	Branch SIF
A15	A-Header F-Branch	60.3 60.3	8.7 8.7	1.4301 1.4301		welding	1.00u	1.00u
A01	A-Header B-Branch	60.3 26.7	8.7 5.6	1.4301 1.4301		welding	1.00u	1.00u
A07	A-Header C-Branch	60.3 21.3	8.7 4.8	1.4301 1.4301		welding	1.00u	1.00u
A10	A-Header D-Branch	60.3 33.4	8.7 4.5	1.4301 1.4301		welding	1.00u	1.00u
B05	B-Header J-Branch	73.0 33.4	9.5 4.5	1.4301 1.4301		welding	1.00u	1.00u
D03	D-Header K-Branch	33.4 21.3	4.5 3.7	1.4301 1.4301		welding	1.00u	1.00u
F13	F-Header H-Branch	60.3 17.1	8.7 3.2	1.4301 1.4301		welding	1.00u	1.00u
F04	F-Header G-Branch	60.3 21.3	8.7 4.8	1.4301 1.4301		welding	1.00u	1.00u
H03	H-Header I-Branch	17.1 17.1	3.2 3.2	1.4301 1.4301		welding	1.00u	1.00u

* = Pad thickness for reinforced tee.
 **= Fillet radius for Raised tee or discontinuity dist. for Thickened tee.
 u = User SIF specified for header or branch, check User SIF data listing.

CIRCUITOPROVABARRE

07/30/2010 CIRCUITO PROVA BARRE
 BENTLEY

02:16 PM

AutoPIPE Plus 9.2.1 MODEL PAGE 34

V A L V E D A T A L I S T I N G

Point Joint Name	Type	Size Dnom /Avg. (mm)	Type /Max. Rating (mm)	Length (mm)	Valve weight (kg)	Actuator weight (kg)	Actuator DX (mm)	Actuator DY (mm)	Actuator DZ (mm)
F08	GATE-F	50	2500	450.85	70				
0.00 WN		1.00							
H08	GLOBE-F	25	NS	254.00	30	40	0.00	-300.00	0.00
0.00 WN		1.00							

CIRCUITOPROVABARRE

07/30/2010 CIRCUITO PROVA BARRE
 BENTLEY

FLANGE DATA LISTING

Point Name	FLG No.	Type	Dnom		Flange weight		Bolt weight	Joint Type	Size		ANSI Check
			(mm)	Rating	(kg)	(kg)	(kg)		/Avg. (mm)	/Max. (mm)	
A20	1	NS	1600	2500	11.0	0.0	USER	1.00		No	
A20	2	NS	1600	2500	14.0	0.0	USER	1.00		No	
A18	1	WELDNECK	50	2500	19.1	0.0	WN	1.00		No	
A18	2	WELDNECK	50	2500	19.1	0.0	WN	1.00		No	
A14	1	WELDNECK	50	2500	19.1	0.0	WN	1.00		No	
A14	2	WELDNECK	50	2500	19.1	0.0	WN	1.00		No	
A04	1	WELDNECK	50	2500	19.1	0.0	WN	1.00		No	
A04	2	WELDNECK	50	2500	19.1	0.0	WN	1.00		No	
A13	1	WELDNECK	50	2500	19.1	0.0	WN	1.00		No	
A13	2	WELDNECK	50	2500	19.1	0.0	WN	1.00		No	
B01	1	WELDNECK	20	2500	4.1	0.0	WN	1.00		No	
B01	2	WELDNECK	20	2500	4.1	0.0	WN	1.00		No	
B08	1	WELDNECK	25	2500	5.9	0.0	WN	1.00		No	
B08	2	BLIND	25	2500	5.4	0.0	USER	1.00		No	
D07	1	WELDNECK	25	2500	5.9	0.0	WN	1.00		No	
D07	2	WELDNECK	25	2500	5.9	0.0	WN	1.00		No	
F02	1	WELDNECK	50	2500	19.1	0.0	WN	1.00		No	
F02	2	WELDNECK	50	2500	19.1	0.0	WN	1.00		No	
F08	1	WELDNECK	50	2500	19.1	0.0	WN	1.00		No	
F09	1	WELDNECK	50	2500	19.1	0.0	WN	1.00		No	
F10	1	WELDNECK	50	2500	19.1	0.0	WN	1.00		No	
F10	2	WELDNECK	50	2500	19.1	0.0	WN	1.00		No	
F11	1	WELDNECK	50	2500	19.1	0.0	WN	1.00		No	
F11	2	WELDNECK	50	2500	19.1	0.0	WN	1.00		No	
H08	1	WELDNECK	25	1500	4.1	0.0	WN	1.00		No	
H09	1	WELDNECK	25	1500	4.1	0.0	WN	1.00		No	
H10	1	WELDNECK	25	2500	5.9	0.0	WN	1.00		No	
H10	2	WELDNECK	25	2500	5.9	0.0	WN	1.00		No	
J04	1	WELDNECK	25	2500	5.9	0.0	WN	1.00		No	
J04	2	WELDNECK	25	2500	5.9	0.0	WN	1.00		No	

CIRCUITOPROVABARRE

07/30/2010 CIRCUITO PROVA BARRE
BENTLEY

JOINT TYPE / USER - SIF DATA LISTING

Point Name	Point Type	SIF in	SIF out	Joint Type	Size		
					/Avg. (mm)	Max. (mm)	Over ride
A17	Run	1.000	1.000	BW	0.0		Yes

circuitoprovabarre.txt

A15	Tee header	2.100	2.100	SW		Yes
A03	F Bend	2.100	2.100	SW		Yes
A01	Tee header	2.100	2.100	SW		Yes
A07	Tee header	2.100	2.100	SW		Yes
A10	Tee header	2.100	2.100	SW		Yes
A01	Tee branch	2.100	2.100	SW		Yes
B05	Tee header	2.100	2.100	SW		Yes
A07	Tee branch	2.100	2.100	SW		Yes
A10	Tee branch	2.100	2.100	SW		Yes
D03	Tee header	2.100	2.100	SW		Yes
A15	Tee branch	2.100	2.100	SW		Yes
F01	Run	1.000	1.000	BW	0.0	Yes
F13	Tee header	2.100	2.100	SW		Yes
F04	Tee header	2.100	2.100	SW		Yes
F04	Tee branch	2.100	2.100	SW		Yes
F13	Tee branch	2.100	2.100	SW		Yes
H03	Tee header	2.100	2.100	SW		Yes
H06	Redu. Near	1.300	1.300	SWN		No
H03	Tee branch	2.100	2.100	SW		Yes
B05	Tee branch	2.100	2.100	SW		Yes
D03	Tee branch	2.100	2.100	SW		Yes

Size/Avg. = Weld Size for SO/SW, Average offset for BW
 Type/Max. = Socket welding type for SW, Maximum offset for BW,
 Concave or Convex for SW and SO (JSME)

□

CIRCUITOPROVABARRE

07/30/2010 CIRCUITO PROVA BARRE
 BENTLEY

02:16 PM

AutoPIPE Plus 9.2.1 MODEL PAGE 37

R E D U C E R D A T A L I S T I N G

		OD		Thk		Cone			
From	To	Length	From	To	From	To	From	Angle	SIF
Point	Point	(mm)	(mm)	(mm)	(mm)	(mm)	Material	(deg)	
B02	B03	64.00	26.7	48.3	5.6	7.1	1.4301		2.00t
B03	B04	89.00	48.3	73.0	7.1	9.5	1.4301		2.00t
B06	B07	89.00	73.0	33.4	9.5	4.5	1.4301		2.00t
H06	H07	50.80	17.1	33.4	3.2	4.5	1.4301		2.00u

u = User-SIF is present at from or to point.
 t = Use SIF of 2.0

□

CIRCUITOPROVABARRE

07/30/2010 CIRCUITO PROVA BARRE
 BENTLEY

02:16 PM

AutoPIPE Plus 9.2.1 MODEL PAGE 38

circuitprovabarre.txt
R I G I D P I P E D A T A L I S T I N G

From Point	To Point	Include Weight	Include Expansion	Rigid Factor
-----	-----	-----	-----	-----

□

CIRCUITOPROVABARRE

07/30/2010 CIRCUITO PROVA BARRE
BENTLEY

02:16 PM

AutoPIPE Plus 9.2.1 MODEL PAGE 39

R E F E R E N C E P O I N T L I S T I N G

(Force - N , Moment - N.m)

Tag No./	Refer.	Point	Seg	Coord.	Load	[Report Loads]	
Ref. ID	Side	Name	Name	System	Direction	Actual	Allow.
-----	-----	-----	-----	-----	-----	-----	-----

□

CIRCUITOPROVABARRE

07/30/2010 CIRCUITO PROVA BARRE
BENTLEY

02:16 PM

AutoPIPE Plus 9.2.1 RESULT PAGE 1

A N A L Y S I S S U M M A R Y

Current model revision number : 259

```

Static - Analysis set number ..... 1
      Date and Time of analysis ..... Jul 27, 2010 10:09 AM
      Model Revision Number ..... 259
      Number of load cases ..... 5
      Load cases analyzed ..... GR HY T1 T2 T3
      Description ..... Analysis Set no. 1
      Gaps/Friction/Soil considered ..... No
      Hanger design run ..... No
      Cut short included ..... No
      Thermal bowing included ..... No
      Include Bourdon rotational effect ..... No
      Pipe radius for Bourdon calculation ... Mean
      Weight of contents included ..... Yes
      Pressure stiffening case ..... None
      Hot modulus case ..... None
      Water elevation for buoyancy loads .... Not considered
      Use corroded thickness in analysis .... No
      Rigid stiffness factor ..... 1000.0
  
```

□

 CIRCUITOPROVABARRE

07/30/2010 CIRCUITO PROVA BARRE
 BENTLEY

02:16 PM AutoPIPE Plus 9.2.1 RESULT PAGE 2

CODE COMPLIANCE COMBINATIONS

<Description>		Allowable	Category	Method	Case/Combination
Combination	Factor M/S K-Factor	(N/mm2)	D/A/P		
GR + Max P{1}	1.00	Automatic	Sustain Y Y Y	Sum	GR[1] Max Long
Max Range	1.00	Automatic	Expansion Y Y Y	Sum	Temp. Range
Amb to T1{1}	1.00	Automatic	Expansion Y Y Y	Sum	T1[1]
Amb to T2{1}	1.00	Automatic	Expansion Y Y Y	Sum	T2[1]
Amb to T3{1}	1.00	Automatic	Expansion Y Y Y	Sum	T3[1]
Hydrotest{1}	1.00 1.000	Automatic	Occasion Y Y Y	Sum	HY[1] Max Long
Max P{1}	1.00	Automatic	Hoop Y Y Y	Sum	Max Hoop
Sus.+T1{1}	1.00	Automatic	Creep Rupt Y Y Y	Sum	Max Sus T1[1]
Sus.+T2{1}	1.00	Automatic	Creep Rupt Y Y Y	Sum	Max Sus T2[1]
Sus.+T3{1}	1.00	Automatic	Creep Rupt Y Y Y	Sum	Max Sus T3[1]

Notes:

D/A/P: [D]efault/[A]uto-update/[P]rint options (Y=Yes, N=No)

□

 CIRCUITOPROVABARRE

07/30/2010 CIRCUITO PROVA BARRE
 BENTLEY

02:16 PM

AutoPIPE Plus 9.2.1 RESULT PAGE 3

NON-CODE COMBINATIONS

<Description>

Combination	Method	Case/Combination	Factor	D/A/P
Gravity{1}	Sum	GR[1]	1.00	Y Y Y
Hydrotest{1}	Sum	HY[1]	1.00	Y Y Y
Thermal 1{1}	Sum	T1[1]	1.00	Y Y Y
Thermal 2{1}	Sum	T2[1]	1.00	Y Y Y
Thermal 3{1}	Sum	T3[1]	1.00	Y Y Y
GRT1{1}	Sum	GR[1] T1[1]	1.00 1.00	Y Y Y
GRT2{1}	Sum	GR[1] T2[1]	1.00 1.00	Y Y Y
GRT3{1}	Sum	GR[1] T3[1]	1.00 1.00	Y Y Y

Notes:

D/A/P: [D]efault/[A]uto-Update/[P]rint options (Y=Yes, N=No)

□

 CIRCUITOPROVABARRE

07/30/2010 CIRCUITO PROVA BARRE
 BENTLEY

02:16 PM

AutoPIPE Plus 9.2.1 RESULT PAGE 4

CODE COMPLIANCE

Y - Factor 0.50
 Weld efficiency factor 1.00
 Range reduction factor 1.00
 Design Pressure Factor 1.00
 Minimum stress ratio used in reports... 0.00
 Number of stress points per span 0
 Include corrosion in stress calcs. N
 Include axial force in code stress N
 Include sustain load margin Only if allowable stress is exceeded

circuitprovabarre.txt

Use single SIF Y
Set sustained/occasional SIF = 1 N
Set sustained/occasional SIF = 0.75i .. N
Apply cold/hot modulus ratio N
Disable auto code combinations N
Disable auto non-code combinations N
No. of thermal ranges to report 0
Include Max Range combination Y
Total stress Octahedral
Direct shear None
Longitudinal pressure calculation PD/4t
Inc. Axial Str and Pcase in Sustained.. N

□

CIRCUITOPROVABARRE

07/30/2010 CIRCUITO PROVA BARRE
BENTLEY

02:16 PM

AutoPIPE Plus 9.2.1 RESULT PAGE 5

HYDROTEST LOAD :

Load case : HY

Specific gravity : 1.00

Temperature load case : Ambient

Temperature load case factor : 1.00

Pressure load case : P1

Pressure load case factor : 1.50

Include insulation : Yes

Included Segments - A B C D F G H I J K

□

CIRCUITOPROVABARRE

07/30/2010 CIRCUITO PROVA BARRE
BENTLEY

02:16 PM

AutoPIPE Plus 9.2.1 RESULT PAGE 6

D I S P L A C E M E N T S

Point) name Z	Load combination	TRANSLATIONS (mm)			ROTATIONS (deg)	
		X	Y	Z	X	Y

*** Segment A begin ***

circuitoprovabarre.txt

A20	Gravity{1}	-2.078	-0.258	-0.336	-0.016	0.040
0.015	Hydrotest{1}	-2.078	-0.332	-0.852	-0.017	0.040
0.015	Thermal 1{1}	0.000	-1.892	-53.188	0.008	0.000
0.000	Thermal 2{1}	0.000	0.483	-53.163	0.044	0.000
0.000	Thermal 3{1}	0.000	-3.210	-15.831	-0.049	0.000
0.000	GRT1{1}	-2.078	-2.150	-53.524	-0.008	0.040
0.015	GRT2{1}	-2.078	0.225	-53.500	0.028	0.040
0.015	GRT3{1}	-2.078	-3.468	-16.167	-0.066	0.040
0.015						
A19	Gravity{1}	-1.764	-0.131	-0.335	-0.016	0.040
0.015	Hydrotest{1}	-1.764	-0.198	-0.831	-0.017	0.040
0.015	Thermal 1{1}	0.000	-1.953	-50.768	0.008	0.000
0.000	Thermal 2{1}	0.000	0.139	-50.744	0.044	0.000
0.000	Thermal 3{1}	0.000	-2.823	-15.111	-0.049	0.000
0.000	GRT1{1}	-1.764	-2.085	-51.103	-0.008	0.040
0.015	GRT2{1}	-1.764	0.007	-51.078	0.028	0.040
0.015	GRT3{1}	-1.764	-2.955	-15.445	-0.066	0.040
0.015						
A18	Gravity{1}	-1.450	-0.005	-0.332	-0.016	0.040
0.015	Hydrotest{1}	-1.450	-0.063	-0.805	-0.017	0.040
0.015	Thermal 1{1}	0.000	-2.014	-48.348	0.008	0.000
0.000	Thermal 2{1}	0.000	-0.205	-48.324	0.044	0.000
0.000	Thermal 3{1}	0.000	-2.437	-14.391	-0.049	0.000
0.000	GRT1{1}	-1.450	-2.019	-48.681	-0.008	0.040
0.015	GRT2{1}	-1.450	-0.210	-48.657	0.028	0.040
0.015	GRT3{1}	-1.450	-2.441	-14.723	-0.066	0.040
0.015						
A17	Gravity{1}	-1.004	0.175	-0.328	-0.016	0.040
0.015	Hydrotest{1}	-1.004	0.127	-0.768	-0.017	0.040
0.015	Thermal 1{1}	0.000	-2.101	-44.913	0.008	0.000
0.000	Thermal 2{1}	0.000	-0.694	-44.889	0.044	0.000
0.000	Thermal 3{1}	0.000	-1.887	-13.369	-0.049	0.000
0.000	GRT1{1}	-1.004	-1.926	-45.241	-0.008	0.040
0.015	GRT2{1}	-1.004	-0.519	-45.217	0.028	0.040
0.015	GRT3{1}	-1.004	-1.712	-13.697	-0.066	0.040
0.015						

circuitoprovabarre.txt

A15	Gravity{1}	-0.959	0.193	-0.328	-0.016	0.040
0.015	Hydrotest{1}	-0.959	0.146	-0.764	-0.017	0.040
0.015	Thermal 1{1}	0.000	-2.110	-44.571	0.008	0.000
0.000	Thermal 2{1}	0.000	-0.742	-44.546	0.044	0.000
0.000	Thermal 3{1}	0.000	-1.833	-13.267	-0.049	0.000
0.000	GRT1{1}	-0.959	-1.917	-44.899	-0.008	0.040
0.015	GRT2{1}	-0.959	-0.549	-44.874	0.028	0.040
0.015	GRT3{1}	-0.959	-1.640	-13.595	-0.066	0.040
0.015						

□

CIRCUITOPROVABARRE

07/30/2010 CIRCUITO PROVA BARRE
BENTLEY

02:16 PM

AutoPIPE Plus 9.2.1

RESULT PAGE 7

D I S P L A C E M E N T S

Point) name Z	Load combination	TRANSLATIONS (mm)			ROTATIONS (deg)	
		X	Y	Z	X	Y
A16	Gravity{1}	-0.915	0.209	-0.327	-0.012	0.040
0.015	Hydrotest{1}	-0.915	0.163	-0.760	-0.013	0.040
0.015	Thermal 1{1}	0.000	-2.111	-44.229	-0.004	0.000
0.000	Thermal 2{1}	0.000	-0.785	-44.204	0.034	0.000
0.000	Thermal 3{1}	0.000	-1.776	-13.165	-0.053	0.000
0.000	GRT1{1}	-0.915	-1.903	-44.556	-0.017	0.040
0.015	GRT2{1}	-0.915	-0.577	-44.532	0.022	0.040
0.015	GRT3{1}	-0.915	-1.567	-13.492	-0.065	0.040
0.015						
A22	Gravity{1}	0.000	0.000	-0.314	0.004	0.030
0.013	Hydrotest{1}	0.000	0.000	-0.668	0.003	0.030
0.013	Thermal 1{1}	0.000	0.000	-36.145	-0.093	0.000
0.000	Thermal 2{1}	0.000	0.000	-36.121	-0.044	0.000
0.000	Thermal 3{1}	0.000	0.000	-10.760	-0.061	0.000
0.000	GRT1{1}	0.000	0.000	-36.460	-0.088	0.030
0.013						

circuitoprovabarre.txt

0.013	GRT2{1}	0.000	0.000	-36.435	-0.039	0.030
0.013	GRT3{1}	0.000	0.000	-11.074	-0.057	0.030
A14 0.006	Gravity{1}	0.890	1.709	-0.274	-0.010	-0.005
0.006	Hydrotest{1}	0.890	1.718	-0.418	-0.009	-0.005
0.000	Thermal 1{1}	0.000	-0.228	-14.744	0.059	0.000
0.000	Thermal 2{1}	0.000	-1.390	-14.720	0.052	0.000
0.000	Thermal 3{1}	0.000	0.520	-4.392	0.025	0.000
0.006	GRT1{1}	0.890	1.481	-15.018	0.049	-0.005
0.006	GRT2{1}	0.890	0.319	-14.993	0.042	-0.005
0.006	GRT3{1}	0.890	2.229	-4.666	0.015	-0.005
A04 0.001	Gravity{1}	0.157	-0.105	-0.241	0.112	-0.030
0.001	Hydrotest{1}	0.157	-0.126	-0.257	0.112	-0.030
0.000	Thermal 1{1}	0.000	-2.458	-1.563	0.030	0.000
0.000	Thermal 2{1}	0.000	-3.106	-1.539	0.016	0.000
0.000	Thermal 3{1}	0.000	-0.483	-0.470	0.014	0.000
0.001	GRT1{1}	0.157	-2.563	-1.805	0.142	-0.030
0.001	GRT2{1}	0.157	-3.211	-1.780	0.128	-0.030
0.001	GRT3{1}	0.157	-0.588	-0.712	0.126	-0.030
A03 N 0.001	Gravity{1}	0.045	-0.537	-0.238	0.126	-0.032
0.001	Hydrotest{1}	0.045	-0.559	-0.243	0.127	-0.032
0.000	Thermal 1{1}	0.000	-2.557	-0.442	0.024	0.000
0.000	Thermal 2{1}	0.000	-3.154	-0.418	0.010	0.000
0.000	Thermal 3{1}	0.000	-0.528	-0.137	0.011	0.000
0.001	GRT1{1}	0.045	-3.094	-0.681	0.150	-0.032
0.001	GRT2{1}	0.045	-3.691	-0.656	0.136	-0.032
0.001	GRT3{1}	0.045	-1.065	-0.375	0.137	-0.032

□

 CIRCUITOPROVABARRE

07/30/2010 CIRCUITO PROVA BARRE
 BENTLEY

02:16 PM

AutoPIPE Plus 9.2.1

RESULT PAGE 8

circuitoprovabarre.txt
D I S P L A C E M E N T S

Point) name Z	Load combination	TRANSLATIONS (mm)			ROTATIONS (deg)	
		X	Y	Z	X	Y
A03 M 0.001	Gravity{1}	0.014	-0.659	-0.186	0.132	-0.033
0.001	Hydrotest{1}	0.014	-0.681	-0.187	0.132	-0.033
0.000	Thermal 1{1}	0.000	-2.457	-0.144	0.021	0.000
0.000	Thermal 2{1}	0.000	-3.041	-0.125	0.007	0.000
0.000	Thermal 3{1}	0.000	-0.502	-0.047	0.009	0.000
0.001	GRT1{1}	0.014	-3.116	-0.330	0.152	-0.033
0.001	GRT2{1}	0.014	-3.700	-0.311	0.139	-0.033
0.001	GRT3{1}	0.014	-1.161	-0.232	0.141	-0.033
A03 F 0.001	Gravity{1}	0.000	-0.711	-0.060	0.127	-0.034
0.001	Hydrotest{1}	0.000	-0.730	-0.060	0.127	-0.034
0.000	Thermal 1{1}	0.000	-2.176	-0.008	0.017	0.000
0.000	Thermal 2{1}	0.000	-2.755	-0.002	0.004	0.000
0.000	Thermal 3{1}	0.000	-0.419	-0.003	0.008	0.000
0.001	GRT1{1}	0.000	-2.887	-0.068	0.145	-0.034
0.001	GRT2{1}	0.000	-3.466	-0.061	0.131	-0.034
0.001	GRT3{1}	0.000	-1.130	-0.063	0.135	-0.034
A00 0.001	Gravity{1}	0.000	-0.711	-0.058	0.127	-0.034
0.001	Hydrotest{1}	0.000	-0.730	-0.059	0.127	-0.034
0.000	Thermal 1{1}	0.000	-2.173	-0.008	0.017	0.000
0.000	Thermal 2{1}	0.000	-2.751	-0.002	0.004	0.000
0.000	Thermal 3{1}	0.000	-0.418	-0.003	0.008	0.000
0.001	GRT1{1}	0.000	-2.884	-0.066	0.145	-0.034
0.001	GRT2{1}	0.000	-3.462	-0.060	0.131	-0.034
0.001	GRT3{1}	0.000	-1.129	-0.062	0.135	-0.034
A25 0.001	Gravity{1}	0.000	-0.711	0.000	0.123	-0.034
0.001	Hydrotest{1}	0.000	-0.728	0.000	0.123	-0.034
0.000	Thermal 1{1}	0.000	-2.034	0.000	0.017	0.000
0.000	Thermal 2{1}	0.000	-2.612	0.000	0.003	0.000

circuitoprovabarre.txt

0.000	Thermal 3{1}	0.000	-0.377	0.000	0.007	0.000
0.000	GRT1{1}	0.000	-2.745	0.000	0.140	-0.034
0.001	GRT2{1}	0.000	-3.323	0.000	0.126	-0.034
0.001	GRT3{1}	0.000	-1.088	0.000	0.130	-0.034
0.001	A01 Gravity{1}	0.000	-0.711	0.078	0.117	-0.035
0.001	Hydrotest{1}	0.000	-0.726	0.078	0.117	-0.035
0.001	Thermal 1{1}	0.000	-1.831	0.011	0.016	0.000
0.000	Thermal 2{1}	0.000	-2.409	0.002	0.002	0.000
0.000	Thermal 3{1}	0.000	-0.316	0.005	0.007	0.000
0.000	GRT1{1}	0.000	-2.542	0.089	0.132	-0.035
0.001	GRT2{1}	0.000	-3.120	0.080	0.119	-0.035
0.001	GRT3{1}	0.000	-1.027	0.082	0.123	-0.035
0.001						

□

CIRCUITOPROVABARRE

07/30/2010 CIRCUITO PROVA BARRE
BENTLEY

02:16 PM

AutoPIPE Plus 9.2.1

RESULT PAGE 9

D I S P L A C E M E N T S

Point) name Z	Load combination	TRANSLATIONS (mm)			ROTATIONS (deg)	
		X	Y	Z	X	Y
A05 0.000	Gravity{1}	-0.001	-0.711	0.250	-0.131	-0.076
0.000	Hydrotest{1}	-0.001	-0.639	0.251	-0.131	-0.076
0.000	Thermal 1{1}	0.000	7.099	0.053	-0.027	0.000
0.000	Thermal 2{1}	0.000	6.521	0.018	-0.009	0.000
0.000	Thermal 3{1}	0.000	2.340	0.009	-0.005	0.000
0.000	GRT1{1}	-0.001	6.388	0.303	-0.158	-0.076
0.000	GRT2{1}	-0.001	5.810	0.268	-0.140	-0.076
0.000	GRT3{1}	-0.001	1.630	0.259	-0.136	-0.076
0.000	A07 Gravity{1}	0.000	-0.711	0.098	-0.145	-0.078

circuitoprovabarre.txt

0.000	Hydrotest{1}	0.000	-0.635	0.098	-0.145	-0.078
0.000	Thermal 1{1}	0.000	7.441	0.021	-0.031	0.000
0.000	Thermal 2{1}	0.000	6.863	0.007	-0.011	0.000
0.000	Thermal 3{1}	0.000	2.442	0.003	-0.005	0.000
0.000	GRT1{1}	0.000	6.731	0.119	-0.175	-0.078
0.000	GRT2{1}	0.000	6.152	0.105	-0.155	-0.078
0.000	GRT3{1}	0.000	1.731	0.101	-0.150	-0.078
A26	Gravity{1}	0.000	-0.711	0.000	-0.153	-0.079
0.000	Hydrotest{1}	0.000	-0.633	0.000	-0.153	-0.079
0.000	Thermal 1{1}	0.000	7.645	0.000	-0.033	0.000
0.000	Thermal 2{1}	0.000	7.066	0.000	-0.011	0.000
0.000	Thermal 3{1}	0.000	2.503	0.000	-0.005	0.000
0.000	GRT1{1}	0.000	6.934	0.000	-0.186	-0.079
0.000	GRT2{1}	0.000	6.355	0.000	-0.165	-0.079
0.000	GRT3{1}	0.000	1.792	0.000	-0.158	-0.079
A08	Gravity{1}	0.000	-0.711	-0.073	-0.158	-0.080
0.000	Hydrotest{1}	0.000	-0.632	-0.073	-0.158	-0.080
0.000	Thermal 1{1}	0.000	7.784	-0.015	-0.034	0.000
0.000	Thermal 2{1}	0.000	7.205	-0.005	-0.012	0.000
0.000	Thermal 3{1}	0.000	2.544	-0.002	-0.005	0.000
0.000	GRT1{1}	0.000	7.073	-0.088	-0.192	-0.080
0.000	GRT2{1}	0.000	6.494	-0.078	-0.170	-0.080
0.000	GRT3{1}	0.000	1.833	-0.075	-0.163	-0.080
A09 N	Gravity{1}	0.000	-0.711	-0.075	-0.158	-0.080
0.000	Hydrotest{1}	0.000	-0.632	-0.075	-0.158	-0.080
0.000	Thermal 1{1}	0.000	7.787	-0.015	-0.034	0.000
0.000	Thermal 2{1}	0.000	7.208	-0.005	-0.012	0.000
0.000	Thermal 3{1}	0.000	2.545	-0.002	-0.005	0.000
0.000	GRT1{1}	0.000	7.076	-0.090	-0.192	-0.080
0.000	GRT2{1}	0.000	6.498	-0.080	-0.170	-0.080
0.000	GRT3{1}	0.000	1.834	-0.077	-0.163	-0.080

□

 CIRCUITOPROVABARRE

07/30/2010 CIRCUITO PROVA BARRE
 BENTLEY

02:16 PM

AutoPIPE Plus 9.2.1

RESULT PAGE 10

D I S P L A C E M E N T S

Point) name Z	Load combination	TRANSLATIONS (mm)			ROTATIONS (deg)	
		X	Y	Z	X	Y
----- A09 M -0.001	Gravity{1}	0.032	-0.775	-0.230	-0.161	-0.081
-0.001	Hydrotest{1}	0.032	-0.694	-0.232	-0.161	-0.081
0.000	Thermal 1{1}	0.000	8.059	-0.170	-0.040	0.000
0.000	Thermal 2{1}	0.000	7.490	-0.138	-0.015	0.000
0.000	Thermal 3{1}	0.000	2.628	-0.043	-0.006	0.000
-0.001	GRT1{1}	0.032	7.284	-0.400	-0.200	-0.081
-0.001	GRT2{1}	0.032	6.715	-0.368	-0.176	-0.081
-0.001	GRT3{1}	0.032	1.853	-0.273	-0.167	-0.081
A09 F 0.000	Gravity{1}	0.109	-0.922	-0.294	-0.150	-0.083
0.000	Hydrotest{1}	0.109	-0.839	-0.298	-0.150	-0.083
0.000	Thermal 1{1}	0.000	8.140	-0.473	-0.045	0.000
0.000	Thermal 2{1}	0.000	7.595	-0.431	-0.018	0.000
0.000	Thermal 3{1}	0.000	2.658	-0.131	-0.007	0.000
0.000	GRT1{1}	0.109	7.218	-0.766	-0.195	-0.083
0.000	GRT2{1}	0.109	6.673	-0.725	-0.167	-0.083
0.000	GRT3{1}	0.109	1.737	-0.425	-0.156	-0.083
A11 0.000	Gravity{1}	0.109	-0.923	-0.294	-0.150	-0.083
0.000	Hydrotest{1}	0.109	-0.841	-0.298	-0.150	-0.083
0.000	Thermal 1{1}	0.000	8.140	-0.476	-0.045	0.000
0.000	Thermal 2{1}	0.000	7.595	-0.434	-0.018	0.000
0.000	Thermal 3{1}	0.000	2.658	-0.132	-0.007	0.000
0.000	GRT1{1}	0.109	7.216	-0.770	-0.195	-0.083
0.000	GRT2{1}	0.109	6.672	-0.728	-0.167	-0.083

circuitoprovabarre.txt

0.000	GRT3{1}	0.109	1.735	-0.426	-0.156	-0.083
A10	Gravity{1}	0.202	-1.084	-0.295	-0.141	-0.084
0.000	Hydrotest{1}	0.202	-1.002	-0.303	-0.141	-0.084
0.000	Thermal 1{1}	0.000	8.088	-0.818	-0.048	0.000
0.000	Thermal 2{1}	0.000	7.574	-0.777	-0.019	0.000
0.000	Thermal 3{1}	0.000	2.651	-0.234	-0.007	0.000
0.000	GRT1{1}	0.202	7.004	-1.114	-0.189	-0.084
0.000	GRT2{1}	0.202	6.490	-1.072	-0.160	-0.084
0.000	GRT3{1}	0.202	1.567	-0.529	-0.147	-0.084
A12	Gravity{1}	0.295	-1.237	-0.297	-0.135	-0.085
0.000	Hydrotest{1}	0.295	-1.155	-0.308	-0.135	-0.085
0.000	Thermal 1{1}	0.000	8.031	-1.161	-0.054	0.000
0.000	Thermal 2{1}	0.000	7.550	-1.119	-0.025	0.000
0.000	Thermal 3{1}	0.000	2.642	-0.336	-0.009	0.000
0.000	GRT1{1}	0.295	6.794	-1.457	-0.189	-0.085
0.000	GRT2{1}	0.295	6.313	-1.415	-0.160	-0.085
0.000	GRT3{1}	0.295	1.405	-0.632	-0.144	-0.085

□

CIRCUITOPROVABARRE

07/30/2010 CIRCUITO PROVA BARRE
BENTLEY

02:16 PM

AutoPIPE Plus 9.2.1

RESULT PAGE 11

D I S P L A C E M E N T S

Point name Z	Load combination	TRANSLATIONS (mm)			ROTATIONS (deg)	
		X	Y	Z	X	Y
A13	Gravity{1}	0.486	-1.524	-0.299	-0.124	-0.087
0.000	Hydrotest{1}	0.486	-1.443	-0.317	-0.125	-0.087
0.000	Thermal 1{1}	0.000	7.897	-1.845	-0.066	0.000
0.000	Thermal 2{1}	0.000	7.480	-1.803	-0.037	0.000
0.000	Thermal 3{1}	0.000	2.619	-0.539	-0.012	0.000

circuitoprovabarre.txt

0.000						
0.000	GRT1{1}	0.486	6.373	-2.144	-0.190	-0.087
0.000	GRT2{1}	0.486	5.956	-2.103	-0.162	-0.087
0.000	GRT3{1}	0.486	1.095	-0.839	-0.136	-0.087
0.000						
	*** Segment A end ***					
	*** Segment B begin ***					
A01	Gravity{1}	0.000	-0.711	0.078	0.117	-0.035
0.001	Hydrotest{1}	0.000	-0.726	0.078	0.117	-0.035
0.001	Thermal 1{1}	0.000	-1.831	0.011	0.016	0.000
0.000	Thermal 2{1}	0.000	-2.409	0.002	0.002	0.000
0.000	Thermal 3{1}	0.000	-0.316	0.005	0.007	0.000
0.000	GRT1{1}	0.000	-2.542	0.089	0.132	-0.035
0.001	GRT2{1}	0.000	-3.120	0.080	0.119	-0.035
0.001	GRT3{1}	0.000	-1.027	0.082	0.123	-0.035
0.001						
B01	Gravity{1}	-0.051	-0.863	0.076	0.026	-0.013
0.001	Hydrotest{1}	-0.051	-0.878	0.079	0.025	-0.013
0.001	Thermal 1{1}	0.000	-1.780	0.726	-0.061	0.000
0.000	Thermal 2{1}	0.000	-2.316	0.717	-0.087	0.000
0.000	Thermal 3{1}	0.000	-0.313	0.267	-0.009	0.000
0.000	GRT1{1}	-0.051	-2.643	0.801	-0.035	-0.013
0.001	GRT2{1}	-0.051	-3.179	0.792	-0.061	-0.013
0.001	GRT3{1}	-0.051	-1.177	0.342	0.017	-0.013
0.001						
B02	Gravity{1}	-0.060	-0.850	0.074	-0.043	0.001
0.001	Hydrotest{1}	-0.060	-0.864	0.080	-0.044	0.001
0.001	Thermal 1{1}	0.000	-1.644	1.252	-0.111	0.000
0.000	Thermal 2{1}	0.000	-2.132	1.244	-0.145	0.000
0.000	Thermal 3{1}	0.000	-0.291	0.460	-0.019	0.000
0.000	GRT1{1}	-0.060	-2.494	1.326	-0.153	0.001
0.001	GRT2{1}	-0.060	-2.983	1.318	-0.188	0.001
0.001	GRT3{1}	-0.060	-1.141	0.534	-0.062	0.001
0.001						
B03	Gravity{1}	-0.057	-0.795	0.073	-0.057	0.004
0.001	Hydrotest{1}	-0.057	-0.807	0.082	-0.058	0.004
0.001	Thermal 1{1}	0.000	-1.515	1.627	-0.120	0.000

circuitoprovabarre.txt

0.000	Thermal 2{1}	0.000	-1.964	1.618	-0.156	0.000
0.000	Thermal 3{1}	0.000	-0.268	0.597	-0.021	0.000
0.000	GRT1{1}	-0.057	-2.310	1.700	-0.176	0.004
0.001	GRT2{1}	-0.057	-2.759	1.691	-0.212	0.004
0.001	GRT3{1}	-0.057	-1.063	0.671	-0.078	0.004

□

 CIRCUITOPROVABARRE

07/30/2010 CIRCUITO PROVA BARRE
 BENTLEY

02:16 PM

AutoPIPE Plus 9.2.1

RESULT PAGE 12

 D I S P L A C E M E N T S

Point) name Z	Load combination	TRANSLATIONS (mm)			ROTATIONS (deg)	
		X	Y	Z	X	Y
----- B04 0.001	Gravity{1}	-0.051	-0.704	0.073	-0.060	0.004
0.001	Hydrotest{1}	-0.051	-0.715	0.086	-0.061	0.004
0.000	Thermal 1{1}	0.000	-1.328	2.148	-0.122	0.000
0.000	Thermal 2{1}	0.000	-1.721	2.139	-0.158	0.000
0.000	Thermal 3{1}	0.000	-0.235	0.788	-0.021	0.000
0.000	GRT1{1}	-0.051	-2.032	2.221	-0.181	0.004
0.001	GRT2{1}	-0.051	-2.425	2.212	-0.218	0.004
0.001	GRT3{1}	-0.051	-0.940	0.861	-0.081	0.004
B09 0.001	Gravity{1}	0.000	0.000	0.071	-0.071	0.005
0.001	Hydrotest{1}	0.000	0.000	0.123	-0.072	0.005
0.000	Thermal 1{1}	0.000	0.000	5.752	-0.124	0.000
0.000	Thermal 2{1}	0.000	0.000	5.744	-0.161	0.000
0.000	Thermal 3{1}	0.000	0.000	2.110	-0.022	0.000
0.000	GRT1{1}	0.000	0.000	5.823	-0.196	0.005
0.001	GRT2{1}	0.000	0.000	5.815	-0.233	0.005
0.001	GRT3{1}	0.000	0.000	2.182	-0.093	0.005
0.001						

circuitoprovabarre.txt

B05	Gravity{1}	0.321	6.931	0.063	-0.144	0.005
0.001	Hydrotest{1}	0.321	6.998	0.345	-0.145	0.005
0.001	Thermal 1{1}	0.000	7.995	27.297	-0.124	0.000
0.000	Thermal 2{1}	0.000	10.354	27.288	-0.161	0.000
0.000	Thermal 3{1}	0.000	1.419	10.012	-0.022	0.000
0.000	GRT1{1}	0.321	14.926	27.360	-0.269	0.005
0.001	GRT2{1}	0.321	17.284	27.351	-0.305	0.005
0.001	GRT3{1}	0.321	8.349	10.075	-0.166	0.005
0.001						
B10	Gravity{1}	0.327	7.097	0.063	-0.144	0.005
0.001	Hydrotest{1}	0.327	7.166	0.349	-0.145	0.005
0.001	Thermal 1{1}	0.000	8.139	27.684	-0.124	0.000
0.000	Thermal 2{1}	0.000	10.540	27.675	-0.161	0.000
0.000	Thermal 3{1}	0.000	1.444	10.154	-0.022	0.000
0.000	GRT1{1}	0.327	15.236	27.747	-0.269	0.005
0.001	GRT2{1}	0.327	17.637	27.738	-0.305	0.005
0.001	GRT3{1}	0.327	8.542	10.217	-0.166	0.005
0.001						
B06	Gravity{1}	0.333	7.264	0.063	-0.144	0.005
0.001	Hydrotest{1}	0.333	7.333	0.353	-0.145	0.005
0.001	Thermal 1{1}	0.000	8.283	28.071	-0.124	0.000
0.000	Thermal 2{1}	0.000	10.726	28.062	-0.161	0.000
0.000	Thermal 3{1}	0.000	1.470	10.296	-0.022	0.000
0.000	GRT1{1}	0.333	15.547	28.134	-0.269	0.005
0.001	GRT2{1}	0.333	17.990	28.125	-0.305	0.005
0.001	GRT3{1}	0.333	8.734	10.359	-0.166	0.005
0.001						

□

 CIRCUITOPROVABARRE

07/30/2010 CIRCUITO PROVA BARRE
 BENTLEY

02:16 PM

AutoPIPE Plus 9.2.1

RESULT PAGE 13

 D I S P L A C E M E N T S

Point Load TRANSLATIONS (mm) ROTATIONS (deg
 Pagina 49

circuitoprovabarre.txt

) name Z	combination	X	Y	Z	X	Y
B07 0.001	Gravity{1}	0.341	7.488	0.063	-0.144	0.005
0.001	Hydrotest{1}	0.341	7.559	0.358	-0.145	0.005
0.000	Thermal 1{1}	0.000	8.476	28.592	-0.124	0.000
0.000	Thermal 2{1}	0.000	10.976	28.583	-0.161	0.000
0.000	Thermal 3{1}	0.000	1.504	10.487	-0.022	0.000
0.001	GRT1{1}	0.341	15.964	28.655	-0.269	0.005
0.001	GRT2{1}	0.341	18.464	28.646	-0.305	0.005
0.001	GRT3{1}	0.341	8.992	10.550	-0.166	0.005
B08 0.001	Gravity{1}	0.366	8.210	0.062	-0.144	0.005
0.001	Hydrotest{1}	0.366	8.286	0.374	-0.145	0.005
0.000	Thermal 1{1}	0.000	9.098	30.268	-0.124	0.000
0.000	Thermal 2{1}	0.000	11.782	30.259	-0.161	0.000
0.000	Thermal 3{1}	0.000	1.614	11.102	-0.022	0.000
0.001	GRT1{1}	0.366	17.308	30.331	-0.269	0.005
0.001	GRT2{1}	0.366	19.992	30.322	-0.305	0.005
0.001	GRT3{1}	0.366	9.824	11.164	-0.166	0.005
*** Segment B end ***						
*** Segment C begin ***						
A07 0.000	Gravity{1}	0.000	-0.711	0.098	-0.145	-0.078
0.000	Hydrotest{1}	0.000	-0.635	0.098	-0.145	-0.078
0.000	Thermal 1{1}	0.000	7.441	0.021	-0.031	0.000
0.000	Thermal 2{1}	0.000	6.863	0.007	-0.011	0.000
0.000	Thermal 3{1}	0.000	2.442	0.003	-0.005	0.000
0.000	GRT1{1}	0.000	6.731	0.119	-0.175	-0.078
0.000	GRT2{1}	0.000	6.152	0.105	-0.155	-0.078
0.000	GRT3{1}	0.000	1.731	0.101	-0.150	-0.078
C01 0.000	Gravity{1}	-0.231	-0.283	0.098	-0.145	-0.078
0.000	Hydrotest{1}	-0.231	-0.207	0.102	-0.145	-0.078
0.000	Thermal 1{1}	0.000	7.532	0.934	-0.031	0.000
0.000	Thermal 2{1}	0.000	6.894	0.921	-0.011	0.000

circuitoprovabarre.txt

0.000	Thermal 3{1}	0.000	2.457	0.367	-0.005	0.000
0.000	GRT1{1}	-0.231	7.249	1.032	-0.175	-0.078
0.000	GRT2{1}	-0.231	6.612	1.019	-0.155	-0.078
0.000	GRT3{1}	-0.231	2.175	0.465	-0.150	-0.078

*** Segment C end ***

*** Segment D begin ***

A10	Gravity{1}	0.202	-1.084	-0.295	-0.141	-0.084
0.000	Hydrotest{1}	0.202	-1.002	-0.303	-0.141	-0.084
0.000	Thermal 1{1}	0.000	8.088	-0.818	-0.048	0.000
0.000	Thermal 2{1}	0.000	7.574	-0.777	-0.019	0.000
0.000	Thermal 3{1}	0.000	2.651	-0.234	-0.007	0.000
0.000	GRT1{1}	0.202	7.004	-1.114	-0.189	-0.084
0.000	GRT2{1}	0.202	6.490	-1.072	-0.160	-0.084
0.000	GRT3{1}	0.202	1.567	-0.529	-0.147	-0.084

□

CIRCUITOPROVABARRE

07/30/2010 CIRCUITO PROVA BARRE
BENTLEY

02:16 PM

AutoPIPE Plus 9.2.1

RESULT PAGE 14

D I S P L A C E M E N T S

Point name Z	Load combination	TRANSLATIONS (mm)			ROTATIONS (deg)	
		X	Y	Z	X	Y
D01	Gravity{1}	0.202	-1.084	-0.406	-0.111	-0.081
0.000	Hydrotest{1}	0.202	-0.999	-0.414	-0.111	-0.081
0.000	Thermal 1{1}	0.000	8.361	-0.850	-0.024	0.000
0.000	Thermal 2{1}	0.000	7.848	-0.775	0.020	0.000
0.000	Thermal 3{1}	0.000	2.732	-0.234	0.005	0.000
0.000	GRT1{1}	0.202	7.278	-1.256	-0.135	-0.081
0.000	GRT2{1}	0.202	6.764	-1.181	-0.091	-0.081
0.000	GRT3{1}	0.202	1.648	-0.641	-0.106	-0.081

circuitoprovabarre.txt

D08	Gravity{1}	0.202	-1.084	-0.491	-0.084	-0.079
0.000	Hydrotest{1}	0.202	-0.996	-0.498	-0.083	-0.079
0.000	Thermal 1{1}	0.000	8.361	-0.861	-0.002	0.000
0.000	Thermal 2{1}	0.000	8.118	-0.741	0.055	0.000
0.000	Thermal 3{1}	0.000	2.812	-0.224	0.016	0.000
0.000	GRT1{1}	0.202	7.278	-1.352	-0.086	-0.079
0.000	GRT2{1}	0.202	7.034	-1.232	-0.028	-0.079
0.000	GRT3{1}	0.202	1.728	-0.715	-0.068	-0.079
D02	Gravity{1}	0.183	-1.084	-0.211	0.101	-0.052
0.003	Hydrotest{1}	0.183	-0.963	-0.201	0.103	-0.052
0.003	Thermal 1{1}	0.000	8.361	-0.174	0.094	0.000
0.000	Thermal 2{1}	0.000	11.165	0.920	0.203	0.000
0.000	Thermal 3{1}	0.000	3.719	0.276	0.060	0.000
0.000	GRT1{1}	0.183	7.278	-0.385	0.195	-0.052
0.003	GRT2{1}	0.183	10.081	0.709	0.303	-0.052
0.003	GRT3{1}	0.183	2.635	0.065	0.161	-0.052
D03	Gravity{1}	0.181	-1.084	-0.142	0.104	-0.050
0.003	Hydrotest{1}	0.181	-0.961	-0.131	0.106	-0.050
0.003	Thermal 1{1}	0.000	8.361	-0.112	0.091	0.000
0.000	Thermal 2{1}	0.000	11.370	1.053	0.196	0.000
0.000	Thermal 3{1}	0.000	3.780	0.315	0.058	0.000
0.000	GRT1{1}	0.181	7.278	-0.254	0.195	-0.050
0.003	GRT2{1}	0.181	10.286	0.910	0.300	-0.050
0.003	GRT3{1}	0.181	2.696	0.172	0.162	-0.050
D04	Gravity{1}	0.179	-1.084	-0.072	0.107	-0.048
0.003	Hydrotest{1}	0.179	-0.958	-0.059	0.109	-0.048
0.003	Thermal 1{1}	0.000	8.361	-0.053	0.086	0.000
0.000	Thermal 2{1}	0.000	11.575	1.181	0.187	0.000
0.000	Thermal 3{1}	0.000	3.841	0.352	0.055	0.000
0.000	GRT1{1}	0.179	7.278	-0.125	0.193	-0.048
0.003	GRT2{1}	0.179	10.491	1.109	0.294	-0.048
0.003	GRT3{1}	0.179	2.757	0.281	0.161	-0.048

□

 CIRCUITOPROVABARRE

07/30/2010 CIRCUITO PROVA BARRE
 BENTLEY

02:16 PM

AutoPIPE Plus 9.2.1

RESULT PAGE 15

D I S P L A C E M E N T S

Point) name Z	Load combination	TRANSLATIONS (mm)			ROTATIONS (deg)	
		X	Y	Z	X	Y
----- D05 N 0.003	Gravity{1}	0.179	-1.084	-0.071	0.107	-0.048
0.003	Hydrotest{1}	0.179	-0.958	-0.058	0.109	-0.048
0.000	Thermal 1{1}	0.000	8.361	-0.052	0.086	0.000
0.000	Thermal 2{1}	0.000	11.579	1.183	0.187	0.000
0.000	Thermal 3{1}	0.000	3.842	0.353	0.054	0.000
0.003	GRT1{1}	0.179	7.278	-0.123	0.193	-0.048
0.003	GRT2{1}	0.179	10.495	1.112	0.294	-0.048
0.003	GRT3{1}	0.179	2.758	0.282	0.161	-0.048
D05 M 0.003	Gravity{1}	0.187	-1.063	-0.021	0.109	-0.047
0.003	Hydrotest{1}	0.187	-0.935	-0.008	0.111	-0.047
0.000	Thermal 1{1}	0.000	8.377	-0.014	0.077	0.000
0.000	Thermal 2{1}	0.000	11.755	1.205	0.171	0.000
0.000	Thermal 3{1}	0.000	3.894	0.359	0.049	0.000
0.003	GRT1{1}	0.187	7.314	-0.035	0.186	-0.047
0.003	GRT2{1}	0.187	10.692	1.185	0.280	-0.047
0.003	GRT3{1}	0.187	2.831	0.338	0.158	-0.047
D05 F 0.003	Gravity{1}	0.207	-1.012	0.001	0.110	-0.045
0.003	Hydrotest{1}	0.207	-0.883	0.012	0.112	-0.045
0.000	Thermal 1{1}	0.000	8.410	0.000	0.067	0.000
0.000	Thermal 2{1}	0.000	11.889	1.096	0.153	0.000
0.000	Thermal 3{1}	0.000	3.933	0.326	0.043	0.000
0.000	GRT1{1}	0.207	7.398	0.001	0.177	-0.045

circuitoprovabarre.txt

0.003						
0.003	GRT2{1}	0.207	10.877	1.096	0.263	-0.045
0.003	GRT3{1}	0.207	2.921	0.327	0.153	-0.045
0.003						
D06	Gravity{1}	0.208	-1.011	0.001	0.110	-0.045
0.003	Hydrotest{1}	0.208	-0.882	0.012	0.112	-0.045
0.003	Thermal 1{1}	0.000	8.411	0.000	0.067	0.000
0.000	Thermal 2{1}	0.000	11.891	1.092	0.153	0.000
0.000	Thermal 3{1}	0.000	3.934	0.325	0.043	0.000
0.000						
0.003	GRT1{1}	0.208	7.400	0.001	0.177	-0.045
0.003	GRT2{1}	0.208	10.880	1.093	0.263	-0.045
0.003	GRT3{1}	0.208	2.922	0.326	0.153	-0.045
0.003						
D07	Gravity{1}	0.280	-0.825	0.001	0.111	-0.041
0.003	Hydrotest{1}	0.280	-0.694	0.007	0.113	-0.041
0.003	Thermal 1{1}	0.000	8.509	0.000	0.051	0.000
0.000	Thermal 2{1}	0.000	12.123	0.575	0.124	0.000
0.000	Thermal 3{1}	0.000	3.997	0.171	0.033	0.000
0.000						
0.000	GRT1{1}	0.280	7.684	0.001	0.162	-0.041
0.003	GRT2{1}	0.280	11.297	0.576	0.235	-0.041
0.003	GRT3{1}	0.280	3.172	0.172	0.144	-0.041
0.003						

*** Segment D end ***

*** Segment F begin ***

□

 CIRCUITOPROVABARRE

07/30/2010 CIRCUITO PROVA BARRE
 BENTLEY

02:16 PM

AutoPIPE Plus 9.2.1

RESULT PAGE 16

 D I S P L A C E M E N T S

Point) name Z	Load combination	TRANSLATIONS (mm)			ROTATIONS (deg)	
		X	Y	Z	X	Y
----- A15 0.015	Gravity{1}	-0.959	0.193	-0.328	-0.016	0.040

circuitoprovabarre.txt

0.015	Hydrotest{1}	-0.959	0.146	-0.764	-0.017	0.040
0.000	Thermal 1{1}	0.000	-2.110	-44.571	0.008	0.000
0.000	Thermal 2{1}	0.000	-0.742	-44.546	0.044	0.000
0.000	Thermal 3{1}	0.000	-1.833	-13.267	-0.049	0.000
0.015	GRT1{1}	-0.959	-1.917	-44.899	-0.008	0.040
0.015	GRT2{1}	-0.959	-0.549	-44.874	0.028	0.040
0.015	GRT3{1}	-0.959	-1.640	-13.595	-0.066	0.040
F01 0.015	Gravity{1}	-0.976	0.193	-0.348	-0.020	0.041
0.015	Hydrotest{1}	-0.976	0.150	-0.785	-0.020	0.041
0.000	Thermal 1{1}	0.000	-1.814	-44.555	0.020	0.000
0.000	Thermal 2{1}	0.000	-0.723	-44.492	0.054	0.000
0.000	Thermal 3{1}	0.000	-1.731	-13.320	-0.046	0.000
0.015	GRT1{1}	-0.976	-1.620	-44.903	0.001	0.041
0.015	GRT2{1}	-0.976	-0.530	-44.840	0.034	0.041
0.015	GRT3{1}	-0.976	-1.538	-13.668	-0.066	0.041
F02 0.016	Gravity{1}	-1.041	0.193	-0.443	-0.022	0.042
0.016	Hydrotest{1}	-1.041	0.163	-0.883	-0.022	0.042
0.000	Thermal 1{1}	0.000	-0.691	-44.375	0.065	0.000
0.000	Thermal 2{1}	0.000	-0.649	-44.189	0.090	0.000
0.000	Thermal 3{1}	0.000	-1.345	-13.486	-0.034	0.000
0.016	GRT1{1}	-1.041	-0.498	-44.818	0.043	0.042
0.016	GRT2{1}	-1.041	-0.456	-44.632	0.068	0.042
0.016	GRT3{1}	-1.041	-1.152	-13.929	-0.055	0.042
F13 0.016	Gravity{1}	-1.117	0.193	-0.530	-0.013	0.044
0.016	Hydrotest{1}	-1.117	0.177	-0.970	-0.013	0.044
0.000	Thermal 1{1}	0.000	0.597	-43.945	0.112	0.000
0.000	Thermal 2{1}	0.000	-0.564	-43.665	0.127	0.000
0.000	Thermal 3{1}	0.000	-0.903	-13.614	-0.020	0.000
0.016	GRT1{1}	-1.117	0.790	-44.475	0.099	0.044
0.016	GRT2{1}	-1.117	-0.370	-44.194	0.113	0.044
0.016	GRT3{1}	-1.117	-0.710	-14.144	-0.033	0.044
F03 0.015	Gravity{1}	-1.452	0.194	-0.445	0.013	0.053

circuitoprovabarre.txt

0.015	Hydrotest{1}	-1.452	0.242	-0.865	0.015	0.053
0.000	Thermal 1{1}	0.000	6.276	-39.849	0.261	0.000
0.000	Thermal 2{1}	0.000	5.115	-39.695	0.233	0.000
0.000	Thermal 3{1}	0.000	1.048	-13.412	0.037	0.000
0.015	GRT1{1}	-1.452	6.469	-40.295	0.274	0.053
0.015	GRT2{1}	-1.452	5.309	-40.140	0.246	0.053
0.015	GRT3{1}	-1.452	1.241	-13.858	0.050	0.053

□

CIRCUITOPROVABARRE

07/30/2010 CIRCUITO PROVA BARRE
BENTLEY

02:16 PM

AutoPIPE Plus 9.2.1

RESULT PAGE 17

D I S P L A C E M E N T S

Point) name Z	Load combination	TRANSLATIONS (mm)			ROTATIONS (deg)	
		X	Y	Z	X	Y
F04 0.015	Gravity{1}	-1.469	0.194	-0.431	0.012	0.054
0.015	Hydrotest{1}	-1.469	0.245	-0.848	0.014	0.054
0.000	Thermal 1{1}	0.000	6.572	-39.557	0.267	0.000
0.000	Thermal 2{1}	0.000	5.412	-39.434	0.237	0.000
0.000	Thermal 3{1}	0.000	1.149	-13.369	0.040	0.000
0.015	GRT1{1}	-1.469	6.766	-39.988	0.279	0.054
0.015	GRT2{1}	-1.469	5.605	-39.865	0.249	0.054
0.015	GRT3{1}	-1.469	1.343	-13.800	0.052	0.054
F05 0.015	Gravity{1}	-1.486	0.194	-0.418	0.011	0.054
0.015	Hydrotest{1}	-1.486	0.248	-0.833	0.013	0.054
0.000	Thermal 1{1}	0.000	6.868	-39.258	0.272	0.000
0.000	Thermal 2{1}	0.000	5.708	-39.170	0.240	0.000
0.000	Thermal 3{1}	0.000	1.251	-13.323	0.043	0.000
0.015	GRT1{1}	-1.486	7.062	-39.676	0.283	0.054
0.015	GRT2{1}	-1.486	5.902	-39.587	0.251	0.054

circuitoprovabarre.txt

0.015	GRT3{1}	-1.486	1.445	-13.741	0.054	0.054
F06 N 0.015	Gravity{1}	-1.486	0.194	-0.417	0.011	0.054
0.015	Hydrotest{1}	-1.486	0.248	-0.833	0.013	0.054
0.015	Thermal 1{1}	0.000	6.871	-39.255	0.272	0.000
0.000	Thermal 2{1}	0.000	5.711	-39.167	0.240	0.000
0.000	Thermal 3{1}	0.000	1.252	-13.323	0.043	0.000
0.015	GRT1{1}	-1.486	7.065	-39.673	0.284	0.054
0.015	GRT2{1}	-1.486	5.905	-39.585	0.251	0.054
0.015	GRT3{1}	-1.486	1.446	-13.740	0.054	0.054
F06 M 0.015	Gravity{1}	-1.479	0.190	-0.408	0.009	0.055
0.015	Hydrotest{1}	-1.479	0.247	-0.820	0.011	0.055
0.015	Thermal 1{1}	0.000	7.012	-38.894	0.280	0.000
0.000	Thermal 2{1}	0.000	5.865	-38.838	0.244	0.000
0.000	Thermal 3{1}	0.000	1.320	-13.246	0.047	0.000
0.015	GRT1{1}	-1.479	7.202	-39.302	0.289	0.055
0.015	GRT2{1}	-1.479	6.055	-39.246	0.253	0.055
0.015	GRT3{1}	-1.479	1.510	-13.653	0.056	0.055
F06 F 0.015	Gravity{1}	-1.433	0.183	-0.404	0.007	0.055
0.015	Hydrotest{1}	-1.433	0.238	-0.813	0.009	0.055
0.015	Thermal 1{1}	0.000	6.852	-38.535	0.287	0.000
0.000	Thermal 2{1}	0.000	5.740	-38.494	0.248	0.000
0.000	Thermal 3{1}	0.000	1.310	-13.141	0.051	0.000
0.015	GRT1{1}	-1.433	7.034	-38.940	0.294	0.055
0.015	GRT2{1}	-1.433	5.923	-38.898	0.254	0.055
0.015	GRT3{1}	-1.433	1.493	-13.546	0.058	0.055

□

 CIRCUITOPROVABARRE

07/30/2010 CIRCUITO PROVA BARRE
 BENTLEY

02:16 PM

AutoPIPE Plus 9.2.1

RESULT PAGE 18

 D I S P L A C E M E N T S

circuitoprovabarre.txt

Point) name Z	Load combination	TRANSLATIONS (mm)			ROTATIONS (deg)	
		X	Y	Z	X	Y
F07	Gravity{1}	-1.433	0.182	-0.404	0.007	0.055
0.015	Hydrotest{1}	-1.433	0.238	-0.813	0.009	0.055
0.015	Thermal 1{1}	0.000	6.848	-38.532	0.288	0.000
0.000	Thermal 2{1}	0.000	5.738	-38.491	0.248	0.000
0.000	Thermal 3{1}	0.000	1.310	-13.140	0.051	0.000
0.015	GRT1{1}	-1.433	7.031	-38.937	0.294	0.055
0.015	GRT2{1}	-1.433	5.920	-38.895	0.254	0.055
0.015	GRT3{1}	-1.433	1.492	-13.545	0.058	0.055
F08	Gravity{1}	-1.301	0.170	-0.404	0.004	0.056
0.015	Hydrotest{1}	-1.301	0.221	-0.806	0.006	0.056
0.015	Thermal 1{1}	0.000	6.155	-37.898	0.295	0.000
0.000	Thermal 2{1}	0.000	5.145	-37.856	0.251	0.000
0.000	Thermal 3{1}	0.000	1.183	-12.922	0.055	0.000
0.000	GRT1{1}	-1.301	6.326	-38.302	0.299	0.056
0.015	GRT2{1}	-1.301	5.315	-38.260	0.255	0.056
0.015	GRT3{1}	-1.301	1.353	-13.327	0.059	0.056
0.015						
F08 M	Gravity{1}	-1.081	0.155	-0.404	0.004	0.056
0.015	Hydrotest{1}	-1.081	0.196	-0.805	0.006	0.056
0.015	Thermal 1{1}	0.000	4.994	-36.845	0.295	0.000
0.000	Thermal 2{1}	0.000	4.158	-36.804	0.251	0.000
0.000	Thermal 3{1}	0.000	0.964	-12.561	0.056	0.000
0.000	GRT1{1}	-1.081	5.149	-37.250	0.299	0.056
0.015	GRT2{1}	-1.081	4.313	-37.208	0.255	0.056
0.015	GRT3{1}	-1.081	1.120	-12.965	0.059	0.056
0.015						
F09	Gravity{1}	-0.860	0.140	-0.404	0.004	0.056
0.015	Hydrotest{1}	-0.860	0.172	-0.805	0.006	0.056
0.015	Thermal 1{1}	0.000	3.832	-35.793	0.295	0.000
0.000	Thermal 2{1}	0.000	3.171	-35.752	0.251	0.000
0.000	Thermal 3{1}	0.000	0.746	-12.199	0.056	0.000

circuitoprovabarre.txt

0.000	GRT1{1}	-0.860	3.972	-36.197	0.299	0.056
0.015	GRT2{1}	-0.860	3.311	-36.156	0.255	0.056
0.015	GRT3{1}	-0.860	0.886	-12.604	0.059	0.056
0.015						
F16	Gravity{1}	0.000	0.000	-0.400	0.021	0.062
0.013	Hydrotest{1}	0.000	0.000	-0.757	0.022	0.062
0.013	Thermal 1{1}	0.000	0.000	-31.886	0.209	0.000
0.000	Thermal 2{1}	0.000	0.000	-31.844	0.167	0.000
0.000	Thermal 3{1}	0.000	0.000	-10.857	0.040	0.000
0.000	GRT1{1}	0.000	0.000	-32.286	0.229	0.062
0.013	GRT2{1}	0.000	0.000	-32.245	0.188	0.062
0.013	GRT3{1}	0.000	0.000	-11.258	0.060	0.062
0.013						

□

 CIRCUITOPROVABARRE

07/30/2010 CIRCUITO PROVA BARRE
 BENTLEY

02:16 PM

AutoPIPE Plus 9.2.1

RESULT PAGE 19

 D I S P L A C E M E N T S

Point) name Z	Load combination	TRANSLATIONS (mm)			ROTATIONS (deg)	
		X	Y	Z	X	Y
----- F10	Gravity{1}	0.617	-0.284	-0.398	0.039	0.070
0.012	Hydrotest{1}	0.617	-0.297	-0.726	0.040	0.070
0.012	Thermal 1{1}	0.000	-1.544	-29.360	0.120	0.000
0.000	Thermal 2{1}	0.000	-1.204	-29.318	0.089	0.000
0.000	Thermal 3{1}	0.000	-0.271	-9.990	0.018	0.000
0.000	GRT1{1}	0.617	-1.828	-29.758	0.159	0.070
0.012	GRT2{1}	0.617	-1.488	-29.716	0.128	0.070
0.012	GRT3{1}	0.617	-0.556	-10.388	0.057	0.070
0.012						
F11	Gravity{1}	2.739	-1.478	-0.389	0.059	0.122
0.009	Hydrotest{1}	2.739	-1.493	-0.647	0.059	0.122
0.009						

circuitoprovabarre.txt

0.000	Thermal 1{1}	0.000	-2.268	-23.193	-0.045	0.000
0.000	Thermal 2{1}	0.000	-1.481	-23.152	-0.054	0.000
0.000	Thermal 3{1}	0.000	-0.202	-7.872	-0.021	0.000
0.009	GRT1{1}	2.739	-3.746	-23.582	0.014	0.122
0.009	GRT2{1}	2.739	-2.959	-23.540	0.005	0.122
0.009	GRT3{1}	2.739	-1.681	-8.260	0.038	0.122
A13 0.000	Gravity{1}	0.486	-1.524	-0.299	-0.124	-0.087
0.000	Hydrotest{1}	0.486	-1.443	-0.317	-0.125	-0.087
0.000	Thermal 1{1}	0.000	7.897	-1.845	-0.066	0.000
0.000	Thermal 2{1}	0.000	7.480	-1.803	-0.037	0.000
0.000	Thermal 3{1}	0.000	2.619	-0.539	-0.012	0.000
0.000	GRT1{1}	0.486	6.373	-2.144	-0.190	-0.087
0.000	GRT2{1}	0.486	5.956	-2.103	-0.162	-0.087
0.000	GRT3{1}	0.486	1.095	-0.839	-0.136	-0.087

*** Segment F end ***

*** Segment G begin ***

F04 0.015	Gravity{1}	-1.469	0.194	-0.431	0.012	0.054
0.015	Hydrotest{1}	-1.469	0.245	-0.848	0.014	0.054
0.000	Thermal 1{1}	0.000	6.572	-39.557	0.267	0.000
0.000	Thermal 2{1}	0.000	5.412	-39.434	0.237	0.000
0.000	Thermal 3{1}	0.000	1.149	-13.369	0.040	0.000
0.015	GRT1{1}	-1.469	6.766	-39.988	0.279	0.054
0.015	GRT2{1}	-1.469	5.605	-39.865	0.249	0.054
0.015	GRT3{1}	-1.469	1.343	-13.800	0.052	0.054
G01 0.015	Gravity{1}	-1.527	0.207	-0.431	0.012	0.054
0.015	Hydrotest{1}	-1.527	0.261	-0.850	0.014	0.054
0.000	Thermal 1{1}	0.000	6.863	-39.849	0.267	0.000
0.000	Thermal 2{1}	0.000	5.670	-39.726	0.237	0.000
0.000	Thermal 3{1}	0.000	1.193	-13.470	0.040	0.000
0.015	GRT1{1}	-1.527	7.070	-40.280	0.279	0.054
0.015	GRT2{1}	-1.527	5.877	-40.157	0.249	0.054
0.015	GRT3{1}	-1.527	1.400	-13.901	0.052	0.054

*** Segment G end ***

*** Segment H begin ***

□

 CIRCUITOPROVABARRE

07/30/2010 CIRCUITO PROVA BARRE
 BENTLEY

02:16 PM

AutoPIPE Plus 9.2.1

RESULT PAGE 20

D I S P L A C E M E N T S

Point) name Z	Load combination	TRANSLATIONS (mm)			ROTATIONS (deg)	
		X	Y	Z	X	Y
----- F13 0.016	Gravity{1}	-1.117	0.193	-0.530	-0.013	0.044
0.016	Hydrotest{1}	-1.117	0.177	-0.970	-0.013	0.044
0.000	Thermal 1{1}	0.000	0.597	-43.945	0.112	0.000
0.000	Thermal 2{1}	0.000	-0.564	-43.665	0.127	0.000
0.000	Thermal 3{1}	0.000	-0.903	-13.614	-0.020	0.000
0.016	GRT1{1}	-1.117	0.790	-44.475	0.099	0.044
0.016	GRT2{1}	-1.117	-0.370	-44.194	0.113	0.044
0.016	GRT3{1}	-1.117	-0.710	-14.144	-0.033	0.044
H01 N 0.017	Gravity{1}	-1.372	0.311	-0.530	0.003	0.043
0.017	Hydrotest{1}	-1.372	0.309	-0.982	0.008	0.043
0.000	Thermal 1{1}	0.000	2.624	-45.512	0.578	0.000
0.000	Thermal 2{1}	0.000	0.757	-43.769	0.328	0.000
0.000	Thermal 3{1}	0.000	-1.021	-14.152	-0.018	0.000
0.017	GRT1{1}	-1.372	2.935	-46.042	0.581	0.043
0.017	GRT2{1}	-1.372	1.069	-44.298	0.332	0.043
0.017	GRT3{1}	-1.372	-0.710	-14.682	-0.014	0.043
H01 M 0.017	Gravity{1}	-1.381	0.311	-0.530	-0.005	0.043
0.017	Hydrotest{1}	-1.381	0.310	-0.982	0.000	0.043
0.000	Thermal 1{1}	0.000	2.728	-45.469	0.604	0.000
0.000	Thermal 2{1}	0.000	0.818	-43.747	0.341	0.000

circuitoprovabarre.txt

0.000	Thermal 3{1}	0.000	-1.017	-14.170	-0.017	0.000
0.017	GRT1{1}	-1.381	3.039	-45.999	0.600	0.043
0.017	GRT2{1}	-1.381	1.129	-44.277	0.336	0.043
0.017	GRT3{1}	-1.381	-0.706	-14.700	-0.021	0.043
H01 F 0.017	Gravity{1}	-1.387	0.311	-0.531	-0.013	0.043
0.017	Hydrotest{1}	-1.387	0.310	-0.982	-0.007	0.043
0.000	Thermal 1{1}	0.000	2.773	-45.360	0.631	0.000
0.000	Thermal 2{1}	0.000	0.846	-43.687	0.353	0.000
0.000	Thermal 3{1}	0.000	-1.002	-14.179	-0.016	0.000
0.017	GRT1{1}	-1.387	3.084	-45.891	0.619	0.043
0.017	GRT2{1}	-1.387	1.157	-44.218	0.341	0.043
0.017	GRT3{1}	-1.387	-0.692	-14.711	-0.029	0.043
H02 0.013	Gravity{1}	-1.948	0.313	-0.410	0.135	0.029
0.013	Hydrotest{1}	-1.948	0.380	-0.450	0.145	0.029
0.000	Thermal 1{1}	0.000	2.773	-2.951	1.023	0.000
0.000	Thermal 2{1}	0.000	1.465	-21.449	0.567	0.000
0.000	Thermal 3{1}	0.000	2.210	-13.405	0.063	0.000
0.013	GRT1{1}	-1.948	3.086	-3.360	1.157	0.029
0.013	GRT2{1}	-1.948	1.778	-21.858	0.701	0.029
0.013	GRT3{1}	-1.948	2.523	-13.814	0.198	0.029

□

 CIRCUITOPROVABARRE

07/30/2010 CIRCUITO PROVA BARRE
 BENTLEY

02:16 PM

AutoPIPE Plus 9.2.1

RESULT PAGE 21

 D I S P L A C E M E N T S

Point) name Z -----	Load combination -----	TRANSLATIONS (mm)			ROTATIONS (deg)	
		X	Y	Z	X	Y
H03 0.013	Gravity{1}	-1.951	0.313	-0.378	0.134	0.029
	Hydrotest{1}	-1.951	0.380	-0.416	0.144	0.029

circuitoprovabarre.txt

0.013						
0.000	Thermal 1{1}	0.000	2.773	-2.711	1.010	0.000
0.000	Thermal 2{1}	0.000	1.469	-21.316	0.561	0.000
0.000	Thermal 3{1}	0.000	2.232	-13.390	0.064	0.000
0.000	GRT1{1}	-1.951	3.086	-3.089	1.143	0.029
0.013	GRT2{1}	-1.951	1.782	-21.694	0.695	0.029
0.013	GRT3{1}	-1.951	2.545	-13.768	0.197	0.029
0.013						
H04	Gravity{1}	-1.954	0.313	-0.347	0.132	0.029
0.013	Hydrotest{1}	-1.954	0.381	-0.382	0.143	0.029
0.013	Thermal 1{1}	0.000	2.773	-2.475	0.996	0.000
0.000	Thermal 2{1}	0.000	1.473	-21.184	0.555	0.000
0.000	Thermal 3{1}	0.000	2.253	-13.375	0.064	0.000
0.000	GRT1{1}	-1.954	3.086	-2.821	1.129	0.029
0.013	GRT2{1}	-1.954	1.786	-21.531	0.688	0.029
0.013	GRT3{1}	-1.954	2.566	-13.721	0.197	0.029
0.013						
H12	Gravity{1}	-1.972	0.313	-0.173	0.122	0.028
0.013	Hydrotest{1}	-1.972	0.383	-0.195	0.132	0.028
0.013	Thermal 1{1}	0.000	2.773	-1.181	0.916	0.000
0.000	Thermal 2{1}	0.000	1.497	-20.457	0.520	0.000
0.000	Thermal 3{1}	0.000	2.378	-13.286	0.067	0.000
0.000	GRT1{1}	-1.972	3.086	-1.354	1.038	0.028
0.013	GRT2{1}	-1.972	1.810	-20.630	0.642	0.028
0.013	GRT3{1}	-1.972	2.691	-13.459	0.190	0.028
0.013						
H05 N	Gravity{1}	-1.986	0.313	-0.046	0.109	0.028
0.012	Hydrotest{1}	-1.986	0.385	-0.057	0.118	0.028
0.012	Thermal 1{1}	0.000	2.773	-0.208	0.846	0.000
0.000	Thermal 2{1}	0.000	1.516	-19.900	0.489	0.000
0.000	Thermal 3{1}	0.000	2.479	-13.210	0.070	0.000
0.000	GRT1{1}	-1.986	3.086	-0.254	0.954	0.028
0.012	GRT2{1}	-1.986	1.830	-19.945	0.598	0.028
0.012	GRT3{1}	-1.986	2.792	-13.255	0.179	0.028
0.012						
H05 M	Gravity{1}	-1.986	0.306	-0.027	0.104	0.028
0.012	Hydrotest{1}	-1.986	0.377	-0.036	0.113	0.028

circuitoprovabarre.txt

0.012	Thermal 1{1}	0.000	2.712	-0.061	0.823	0.000
0.000	Thermal 2{1}	0.000	1.484	-19.813	0.479	0.000
0.000	Thermal 3{1}	0.000	2.490	-13.191	0.071	0.000
0.000	GRT1{1}	-1.986	3.018	-0.088	0.927	0.028
0.012	GRT2{1}	-1.986	1.790	-19.840	0.583	0.028
0.012	GRT3{1}	-1.986	2.796	-13.218	0.175	0.028
0.012						

□

 CIRCUITOPROVABARRE

07/30/2010 CIRCUITO PROVA BARRE
 BENTLEY

02:16 PM

AutoPIPE Plus 9.2.1

RESULT PAGE 22

 D I S P L A C E M E N T S

Point) name Z	Load combination	TRANSLATIONS (mm)			ROTATIONS (deg)	
		X	Y	Z	X	Y
----- H05 F 0.012	Gravity{1}	-1.982	0.288	-0.019	0.099	0.028
0.012	Hydrotest{1}	-1.982	0.358	-0.028	0.108	0.028
0.000	Thermal 1{1}	0.000	2.569	-0.002	0.800	0.000
0.000	Thermal 2{1}	0.000	1.402	-19.775	0.469	0.000
0.000	Thermal 3{1}	0.000	2.484	-13.169	0.072	0.000
0.012	GRT1{1}	-1.982	2.857	-0.021	0.899	0.028
0.012	GRT2{1}	-1.982	1.690	-19.795	0.568	0.028
0.012	GRT3{1}	-1.982	2.772	-13.189	0.171	0.028
H06 0.008	Gravity{1}	-1.702	-1.783	-0.019	0.454	0.025
0.008	Hydrotest{1}	-1.702	-1.772	-0.007	0.456	0.025
0.000	Thermal 1{1}	0.000	-2.229	-0.001	0.106	0.000
0.000	Thermal 2{1}	0.000	-1.767	-19.586	0.112	0.000
0.000	Thermal 3{1}	0.000	1.692	-12.189	0.066	0.000
0.008	GRT1{1}	-1.702	-4.012	-0.020	0.560	0.025
0.008	GRT2{1}	-1.702	-3.550	-19.605	0.566	0.025
0.008	GRT3{1}	-1.702	-0.092	-12.208	0.520	0.025

circuitoprovabarre.txt

0.008						
H07	Gravity{1}	-1.680	-2.193	-0.019	0.471	0.025
0.008	Hydrotest{1}	-1.680	-2.183	-0.004	0.473	0.025
0.008	Thermal 1{1}	0.000	-2.317	-0.001	0.093	0.000
0.000	Thermal 2{1}	0.000	-1.862	-19.571	0.104	0.000
0.000	Thermal 3{1}	0.000	1.633	-12.108	0.066	0.000
0.000	GRT1{1}	-1.680	-4.510	-0.020	0.564	0.025
0.008	GRT2{1}	-1.680	-4.055	-19.589	0.575	0.025
0.008	GRT3{1}	-1.680	-0.560	-12.127	0.537	0.025
0.008						
H08	Gravity{1}	-1.647	-2.816	-0.019	0.481	0.025
0.008	Hydrotest{1}	-1.647	-2.809	0.000	0.483	0.025
0.008	Thermal 1{1}	0.000	-2.435	-0.001	0.087	0.000
0.000	Thermal 2{1}	0.000	-1.995	-19.547	0.100	0.000
0.000	Thermal 3{1}	0.000	1.547	-11.988	0.065	0.000
0.000	GRT1{1}	-1.647	-5.251	-0.020	0.568	0.025
0.008	GRT2{1}	-1.647	-4.811	-19.566	0.581	0.025
0.008	GRT3{1}	-1.647	-1.268	-12.006	0.546	0.025
0.008						
H08 M	Gravity{1}	-1.591	-3.882	-0.019	0.481	0.025
0.008	Hydrotest{1}	-1.591	-3.879	0.000	0.483	0.025
0.008	Thermal 1{1}	0.000	-2.627	-0.001	0.087	0.000
0.000	Thermal 2{1}	0.000	-2.217	-19.508	0.100	0.000
0.000	Thermal 3{1}	0.000	1.403	-11.784	0.065	0.000
0.000	GRT1{1}	-1.591	-6.509	-0.020	0.568	0.025
0.008	GRT2{1}	-1.591	-6.099	-19.527	0.581	0.025
0.008	GRT3{1}	-1.591	-2.479	-11.803	0.546	0.025
0.008						

□

 CIRCUITOPROVABARRE

07/30/2010 CIRCUITO PROVA BARRE
 BENTLEY

02:16 PM

AutoPIPE Plus 9.2.1

RESULT PAGE 23

 D I S P L A C E M E N T S

circuitoprovabarre.txt

Point) name Z	Load combination	TRANSLATIONS (mm)			ROTATIONS (deg)	
		X	Y	Z	X	Y
H09 0.008	Gravity{1}	-1.536	-4.948	-0.019	0.480	0.025
0.008	Hydrotest{1}	-1.536	-4.949	0.000	0.482	0.025
0.000	Thermal 1{1}	0.000	-2.819	-0.001	0.087	0.000
0.000	Thermal 2{1}	0.000	-2.438	-19.469	0.100	0.000
0.000	Thermal 3{1}	0.000	1.258	-11.580	0.065	0.000
0.008	GRT1{1}	-1.536	-7.767	-0.020	0.567	0.025
0.008	GRT2{1}	-1.536	-7.385	-19.488	0.580	0.025
0.008	GRT3{1}	-1.536	-3.690	-11.599	0.546	0.025
H17 0.006	Gravity{1}	0.000	0.000	-0.027	-0.208	0.026
0.006	Hydrotest{1}	0.000	0.000	-0.017	-0.210	0.026
0.000	Thermal 1{1}	0.000	0.000	-0.001	-0.161	0.000
0.000	Thermal 2{1}	0.000	0.000	-18.402	-0.215	0.000
0.000	Thermal 3{1}	0.000	0.000	-6.000	-0.051	0.000
0.006	GRT1{1}	0.000	0.000	-0.027	-0.369	0.026
0.006	GRT2{1}	0.000	0.000	-18.429	-0.423	0.026
0.006	GRT3{1}	0.000	0.000	-6.027	-0.259	0.026
H10 0.006	Gravity{1}	0.159	1.085	-0.027	-0.149	0.026
0.006	Hydrotest{1}	0.159	1.100	-0.018	-0.152	0.026
0.000	Thermal 1{1}	0.000	1.037	-0.001	-0.177	0.000
0.000	Thermal 2{1}	0.000	1.430	-18.295	-0.251	0.000
0.000	Thermal 3{1}	0.000	0.366	-5.440	-0.068	0.000
0.006	GRT1{1}	0.159	2.121	-0.028	-0.326	0.026
0.006	GRT2{1}	0.159	2.515	-18.322	-0.400	0.026
0.006	GRT3{1}	0.159	1.451	-5.468	-0.217	0.026
H20 0.004	Gravity{1}	0.353	-0.617	0.000	0.112	-0.037
0.004	Hydrotest{1}	0.353	-0.484	0.000	0.113	-0.037
0.000	Thermal 1{1}	0.000	8.587	0.000	0.033	0.000
0.000	Thermal 2{1}	0.000	12.321	0.000	0.093	0.000
0.000	Thermal 3{1}	0.000	4.048	0.000	0.023	0.000

circuitoprovabarre.txt

0.004	GRT1{1}	0.353	7.970	0.000	0.146	-0.037
0.004	GRT2{1}	0.353	11.704	0.000	0.205	-0.037
0.004	GRT3{1}	0.353	3.431	0.000	0.135	-0.037
D07 0.003	Gravity{1}	0.280	-0.825	0.001	0.111	-0.041
0.003	Hydrotest{1}	0.280	-0.694	0.007	0.113	-0.041
0.000	Thermal 1{1}	0.000	8.509	0.000	0.051	0.000
0.000	Thermal 2{1}	0.000	12.123	0.575	0.124	0.000
0.000	Thermal 3{1}	0.000	3.997	0.171	0.033	0.000
0.003	GRT1{1}	0.280	7.684	0.001	0.162	-0.041
0.003	GRT2{1}	0.280	11.297	0.576	0.235	-0.041
0.003	GRT3{1}	0.280	3.172	0.172	0.144	-0.041

*** Segment H end ***

*** Segment I begin ***

□

 CIRCUITOPROVABARRE

07/30/2010 CIRCUITO PROVA BARRE
 BENTLEY

02:16 PM

AutoPIPE Plus 9.2.1

RESULT PAGE 24

D I S P L A C E M E N T S

Point) name Z	Load combination	TRANSLATIONS (mm)			ROTATIONS (deg)	
		X	Y	Z	X	Y
H03 0.013	Gravity{1}	-1.951	0.313	-0.378	0.134	0.029
0.013	Hydrotest{1}	-1.951	0.380	-0.416	0.144	0.029
0.000	Thermal 1{1}	0.000	2.773	-2.711	1.010	0.000
0.000	Thermal 2{1}	0.000	1.469	-21.316	0.561	0.000
0.000	Thermal 3{1}	0.000	2.232	-13.390	0.064	0.000
0.013	GRT1{1}	-1.951	3.086	-3.089	1.143	0.029
0.013	GRT2{1}	-1.951	1.782	-21.694	0.695	0.029
0.013	GRT3{1}	-1.951	2.545	-13.768	0.197	0.029
I02	Gravity{1}	-2.014	0.605	-0.378	0.134	0.029

circuitoprovabarre.txt

0.013						
0.013	Hydrotest{1}	-2.014	0.695	-0.420	0.144	0.029
0.013	Thermal 1{1}	0.000	4.976	-2.711	1.010	0.000
0.000	Thermal 2{1}	0.000	2.693	-21.354	0.561	0.000
0.000	Thermal 3{1}	0.000	2.370	-13.590	0.064	0.000
0.013	GRT1{1}	-2.014	5.580	-3.089	1.143	0.029
0.013	GRT2{1}	-2.014	3.297	-21.732	0.695	0.029
0.013	GRT3{1}	-2.014	2.975	-13.968	0.197	0.029
0.013						
I01	Gravity{1}	-1.958	0.345	-0.378	0.134	0.029
0.013	Hydrotest{1}	-1.958	0.414	-0.416	0.144	0.029
0.013	Thermal 1{1}	0.000	3.011	-2.711	1.010	0.000
0.000	Thermal 2{1}	0.000	1.601	-21.320	0.561	0.000
0.000	Thermal 3{1}	0.000	2.247	-13.411	0.064	0.000
0.000	GRT1{1}	-1.958	3.356	-3.089	1.143	0.029
0.013	GRT2{1}	-1.958	1.945	-21.698	0.695	0.029
0.013	GRT3{1}	-1.958	2.591	-13.789	0.197	0.029
0.013						

*** Segment I end ***

*** Segment J begin ***

B05	Gravity{1}	0.321	6.931	0.063	-0.144	0.005
0.001	Hydrotest{1}	0.321	6.998	0.345	-0.145	0.005
0.001	Thermal 1{1}	0.000	7.995	27.297	-0.124	0.000
0.000	Thermal 2{1}	0.000	10.354	27.288	-0.161	0.000
0.000	Thermal 3{1}	0.000	1.419	10.012	-0.022	0.000
0.000	GRT1{1}	0.321	14.926	27.360	-0.269	0.005
0.001	GRT2{1}	0.321	17.284	27.351	-0.305	0.005
0.001	GRT3{1}	0.321	8.349	10.075	-0.166	0.005
0.001						
J01	Gravity{1}	0.316	6.931	-1.678	-0.252	0.005
0.001	Hydrotest{1}	0.316	7.025	-1.406	-0.253	0.005
0.001	Thermal 1{1}	0.000	10.716	26.287	-0.124	0.000
0.000	Thermal 2{1}	0.000	13.075	25.980	-0.161	0.000
0.000	Thermal 3{1}	0.000	2.417	9.833	-0.022	0.000
0.000	GRT1{1}	0.316	17.647	24.608	-0.377	0.005
0.001	GRT2{1}	0.316	20.006	24.302	-0.413	0.005
0.001						

0.001 GRT3{1} 0.316 9.347 8.155 -0.274 0.005

□

CIRCUITOPROVABARRE

07/30/2010 CIRCUITO PROVA BARRE
BENTLEY

02:16 PM

AutoPIPE Plus 9.2.1 RESULT PAGE 25

D I S P L A C E M E N T S

Point) name Z	Load combination	TRANSLATIONS (mm)			ROTATIONS (deg)	
		X	Y	Z	X	Y
0.001 J02 N	Gravity{1}	0.316	6.931	-1.681	-0.252	0.005
0.001	Hydrotest{1}	0.316	7.025	-1.408	-0.253	0.005
0.000	Thermal 1{1}	0.000	10.720	26.285	-0.124	0.000
0.000	Thermal 2{1}	0.000	13.079	25.978	-0.161	0.000
0.000	Thermal 3{1}	0.000	2.418	9.833	-0.022	0.000
0.001	GRT1{1}	0.316	17.651	24.604	-0.377	0.005
0.001	GRT2{1}	0.316	20.009	24.297	-0.413	0.005
0.001	GRT3{1}	0.316	9.349	8.152	-0.274	0.005
0.001 J02 F	Gravity{1}	0.319	7.097	-1.847	-0.253	0.005
0.001	Hydrotest{1}	0.319	7.194	-1.573	-0.255	0.005
0.000	Thermal 1{1}	0.000	11.021	26.423	-0.124	0.000
0.000	Thermal 2{1}	0.000	13.403	26.092	-0.161	0.000
0.000	Thermal 3{1}	0.000	2.513	9.899	-0.022	0.000
0.001	GRT1{1}	0.319	18.117	24.577	-0.378	0.005
0.001	GRT2{1}	0.319	20.500	24.245	-0.415	0.005
0.001	GRT3{1}	0.319	9.609	8.052	-0.276	0.005
0.001 J03	Gravity{1}	0.319	7.099	-1.847	-0.253	0.005
0.001	Hydrotest{1}	0.319	7.196	-1.573	-0.255	0.005
0.000	Thermal 1{1}	0.000	11.022	26.427	-0.124	0.000
0.000	Thermal 2{1}	0.000	13.405	26.096	-0.161	0.000
0.000	Thermal 3{1}	0.000	2.513	9.900	-0.022	0.000

circuitoprovabarre.txt

0.000						
0.001	GRT1{1}	0.319	18.121	24.580	-0.378	0.005
0.001	GRT2{1}	0.319	20.504	24.249	-0.415	0.005
0.001	GRT3{1}	0.319	9.613	8.053	-0.276	0.005
0.001						
J04	Gravity{1}	0.340	8.166	-1.847	-0.253	0.005
0.001	Hydrotest{1}	0.340	8.267	-1.559	-0.255	0.005
0.001	Thermal 1{1}	0.000	11.545	27.837	-0.124	0.000
0.000	Thermal 2{1}	0.000	14.083	27.506	-0.161	0.000
0.000	Thermal 3{1}	0.000	2.606	10.417	-0.022	0.000
0.000	GRT1{1}	0.340	19.711	25.990	-0.378	0.005
0.001	GRT2{1}	0.340	22.248	25.659	-0.415	0.005
0.001	GRT3{1}	0.340	10.772	8.570	-0.276	0.005
0.001						

*** Segment J end ***

*** Segment K begin ***

D03	Gravity{1}	0.181	-1.084	-0.142	0.104	-0.050
0.003	Hydrotest{1}	0.181	-0.961	-0.131	0.106	-0.050
0.003	Thermal 1{1}	0.000	8.361	-0.112	0.091	0.000
0.000	Thermal 2{1}	0.000	11.370	1.053	0.196	0.000
0.000	Thermal 3{1}	0.000	3.780	0.315	0.058	0.000
0.000	GRT1{1}	0.181	7.278	-0.254	0.195	-0.050
0.003	GRT2{1}	0.181	10.286	0.910	0.300	-0.050
0.003	GRT3{1}	0.181	2.696	0.172	0.162	-0.050
0.003						

□

 CIRCUITOPROVABARRE

07/30/2010 CIRCUITO PROVA BARRE
 BENTLEY

02:16 PM

AutoPIPE Plus 9.2.1

RESULT PAGE 26

 D I S P L A C E M E N T S

Point) name Z	Load combination	TRANSLATIONS (mm)			ROTATIONS (deg)	
		X	Y	Z	X	Y
-----	-----	-----	-----	-----	-----	-----
-----	-----	-----	-----	-----	-----	-----

circuitoprovabarre.txt

K01	Gravity{1}	0.037	-1.384	-0.142	0.104	-0.050
0.003	Hydrotest{1}	0.037	-1.267	-0.125	0.106	-0.050
0.003	Thermal 1{1}	0.000	8.100	-0.112	0.091	0.000
0.000	Thermal 2{1}	0.000	10.806	1.942	0.196	0.000
0.000	Thermal 3{1}	0.000	3.614	0.579	0.058	0.000
0.000	GRT1{1}	0.037	6.716	-0.254	0.195	-0.050
0.003	GRT2{1}	0.037	9.421	1.799	0.300	-0.050
0.003	GRT3{1}	0.037	2.230	0.437	0.162	-0.050
0.003						

*** Segment K end ***

H08 M	Gravity{1}	-1.591	-3.882	-0.019	0.481	0.025
0.008	Hydrotest{1}	-1.591	-3.879	0.000	0.483	0.025
0.008	Thermal 1{1}	0.000	-2.627	-0.001	0.087	0.000
0.000	Thermal 2{1}	0.000	-2.217	-19.508	0.100	0.000
0.000	Thermal 3{1}	0.000	1.403	-11.784	0.065	0.000
0.000	GRT1{1}	-1.591	-6.509	-0.020	0.568	0.025
0.008	GRT2{1}	-1.591	-6.099	-19.527	0.581	0.025
0.008	GRT3{1}	-1.591	-2.479	-11.803	0.546	0.025
0.008						

H08 D	Gravity{1}	-1.551	-3.882	-2.538	0.481	0.025
0.008	Hydrotest{1}	-1.551	-3.879	-2.530	0.483	0.025
0.008	Thermal 1{1}	0.000	-2.627	-0.455	0.087	0.000
0.000	Thermal 2{1}	0.000	-2.217	-20.030	0.100	0.000
0.000	Thermal 3{1}	0.000	1.403	-12.125	0.065	0.000
0.000	GRT1{1}	-1.551	-6.509	-2.993	0.568	0.025
0.008	GRT2{1}	-1.551	-6.099	-22.569	0.581	0.025
0.008	GRT3{1}	-1.551	-2.479	-14.664	0.546	0.025
0.008						

 CIRCUITOPROVABARRE

07/30/2010 CIRCUITO PROVA BARRE
 BENTLEY

02:16 PM

AutoPIPE Plus 9.2.1

RESULT PAGE 27

 S U P P O R T F O R C E S
 (Force - N , Moment - N.m , Tran. - mm , Rot. - deg)

circuitoprovabarre.txt

Point/ B A L	Connect/ Supp. ID	Load Type	Combination	Dirn	L O C A L Force	Deform	G L O Dirn
Tag No.: <None>							
A22			Gravity{1}	down	2	0.000	X
-2	0.000						
A22	1	Guide		right	135	0.000	Y
135	0.000						
Stiff		:RIGID		back		0.314	Z
-0.314							
			Hydrotest{1}	down	2	0.000	X
-2	0.000						
				right	132	0.000	Y
132	0.000						
				back		0.668	Z
-0.668							
			Thermal 1{1}	down		0.000	X
	0.000						
				left	314	0.000	Y
-314	0.000						
				back		36.145	Z
-36.145							
			Thermal 2{1}	down		0.000	X
	0.000						
				left	245	0.000	Y
-245	0.000						
				back		36.121	Z
-36.121							
			Thermal 3{1}	down		0.000	X
	0.000						
				left	112	0.000	Y
-112	0.000						
				back		10.760	Z
-10.760							
			GRT1{1}	down	2	0.000	X
-2	0.000						
				left	178	0.000	Y
-178	0.000						
				back		36.460	Z
-36.460							
			GRT2{1}	down	2	0.000	X
-2	0.000						
				left	110	0.000	Y
-110	0.000						
				back		36.435	Z
-36.435							
			GRT3{1}	down	2	0.000	X
-2	0.000						
				right	24	0.000	Y
24	0.000						
				back		11.074	Z
-11.074							
Tag No.: <None>							
A25			Gravity{1}	down	5709	0.000	X
15	0.000						
A25	1	Guide		right	15	0.000	Y

circuitoprovabarre.txt

```

-0.711
Stiff :RIGID
-5709 0.000
    back 0.711 Z

15 0.000 Hydrotest{1}
    down 5709 0.000 X
    right 15 0.000 Y
-0.728
-5709 0.000
    back 0.728 Z

0.000 Thermal 1{1}
    up 153 0.000 X
    left 0.000 Y
-2.034
153 0.000
    back 2.034 Z

0.000 Thermal 2{1}
    up 131 0.000 X
    left 0.000 Y
-2.612
131 0.000
    back 2.612 Z

0.000 Thermal 3{1}
    up 3 0.000 X

```

□

CIRCUITOPROVABARRE

07/30/2010 CIRCUITO PROVA BARRE
BENTLEY

02:16 PM

AutoPIPE Plus 9.2.1 RESULT PAGE 28

S U P P O R T F O R C E S

(Force - N , Moment - N.m , Tran. - mm , Rot. - deg)

Point/ B A L	Connect/ Supp. ID	Load Type	Combination	L O C A L		G L O
				Dirn	Force	Deform
				left	0.000	Y
				back	0.377	Z
3	0.000					
		GRT1{1}		down	5557	X
15	0.000			right	15	Y
				back	2.745	Z
-5557	0.000					
		GRT2{1}		down	5579	X
15	0.000			right	15	Y
				back	3.323	Z
-5579	0.000					

15	0.000	GRT3{1}	down	5706	0.000	X
	-1.088		right	15	0.000	Y
			back		1.088	Z
-5706	0.000					
Tag No.: <None>						
A26		Gravity{1}	down	6416	0.000	X
42	0.000		right	42	0.000	Y
A26	1	Guide	back		0.711	Z
	-0.711					
Stiff	:RIGID					
-6416	0.000					
		Hydrotest{1}	down	6414	0.000	X
42	0.000		right	42	0.000	Y
	-0.633		back		0.633	Z
-6414	0.000					
		Thermal 1{1}	down	5	0.000	X
	0.000		left		0.000	Y
	7.645		forw		7.645	Z
-5	0.000					
		Thermal 2{1}	up	97	0.000	X
	0.000		left		0.000	Y
	7.066		forw		7.066	Z
97	0.000					
		Thermal 3{1}	up	68	0.000	X
	0.000		left		0.000	Y
	2.503		forw		2.503	Z
68	0.000					
		GRT1{1}	down	6421	0.000	X
42	0.000		right	42	0.000	Y
	6.934		forw		6.934	Z
-6421	0.000					
		GRT2{1}	down	6319	0.000	X
42	0.000		right	42	0.000	Y
	6.355		forw		6.355	Z
-6319	0.000					
		GRT3{1}	down	6349	0.000	X
42	0.000		right	42	0.000	Y
	1.792		forw		1.792	Z
-6349	0.000					
Tag No.: <None>						
B09		Gravity{1}	down	15	0.000	X
-15	0.000		right	11	0.000	Y
B09	1	Guide				

circuitoprovabarre.txt

11 0.000
 Stiff :RIGID forw 0.071 Z
 0.071

□

CIRCUITOPROVABARRE

07/30/2010 CIRCUITO PROVA BARRE
 BENTLEY

02:16 PM AutoPIPE Plus 9.2.1 RESULT PAGE 29

S U P P O R T F O R C E S

(Force - N , Moment - N.m , Tran. - mm , Rot. - deg)

Point/ B A L	Connect/ Supp. ID	Load Type Combination	L O C A L		G L O	
			Dirn	Force		Deform
Force	Deform					
-15	0.000	Hydrotest{1}	down	15	0.000	X
11	0.000		rght	11	0.000	Y
	0.123		forw		0.123	Z
	0.000	Thermal 1{1}	down		0.000	X
-52	0.000		left	52	0.000	Y
	5.752		forw		5.752	Z
	0.000	Thermal 2{1}	down		0.000	X
-61	0.000		left	61	0.000	Y
	5.744		forw		5.744	Z
	0.000	Thermal 3{1}	down		0.000	X
-11	0.000		left	11	0.000	Y
	2.110		forw		2.110	Z
-15	0.000	GRT1{1}	down	15	0.000	X
-41	0.000		left	41	0.000	Y
	5.823		forw		5.823	Z
-15	0.000	GRT2{1}	down	15	0.000	X
-49	0.000		left	49	0.000	Y
	5.815		forw		5.815	Z

-15	0.000	GRT3{1}	down	15	0.000	X
1	0.000		rght	1	0.000	Y
	2.182		forw		2.182	Z
Tag No.: <None>						
F16		Gravity{1}	down	42	0.000	X
-42	0.000					
F16	1	Guide	left	106	0.000	Y
-106	0.000					
Stiff		:RIGID	back		0.400	Z
	-0.400					
-42	0.000	Hydrotest{1}	down	42	0.000	X
			left	102	0.000	Y
-102	0.000		back		0.757	Z
	-0.757					
	0.000	Thermal 1{1}	down		0.000	X
			rght	358	0.000	Y
358	0.000		back		31.886	Z
	-31.886					
	0.000	Thermal 2{1}	down		0.000	X
			rght	287	0.000	Y
287	0.000		back		31.844	Z
	-31.844					
	0.000	Thermal 3{1}	down		0.000	X
			rght	114	0.000	Y
114	0.000		back		10.857	Z
	-10.857					
-42	0.000	GRT1{1}	down	42	0.000	X
			rght	252	0.000	Y
252	0.000		back		32.286	Z
	-32.286					

□

 CIRCUITOPROVABARRE

07/30/2010 CIRCUITO PROVA BARRE
 BENTLEY

02:16 PM

AutoPIPE Plus 9.2.1

RESULT PAGE 30

S U P P O R T F O R C E S

(Force - N , Moment - N.m , Tran. - mm , Rot. - deg)

Point/ Connect/ Load
 B A L

L O C A L

G L O

circuitoprovabarre.txt

Supp. Force	ID Deform	Type	Combination	Dirn	Force	Deform	Dirn
-42	0.000		GRT2{1}	down	42	0.000	X
181	0.000			right	181	0.000	Y
	-32.245			back		32.245	Z
-42	0.000		GRT3{1}	down	42	0.000	X
8	0.000			right	8	0.000	Y
	-11.258			back		11.258	Z
Tag No.: <None>							
H08	M		Gravity{1}	down	1042	0.019	X
	-1.591						Y
H08	M1	Spr. Hgr					Z
	-3.882						
Stiff	:	11					
-1042	-0.019						
Preload :	1041		Hydrotest{1}	down	6060	0.000	X
	-1.591						Y
	-3.879						Z
-6060	0.000						
	0.000		Thermal 1{1}	down	0	0.001	X
	-2.627						Y
0	-0.001						Z
	0.000		Thermal 2{1}	down	215	19.508	X
	-2.217						Y
-215	-19.508						Z
	0.000		Thermal 3{1}	down	130	11.784	X
	1.403						Y
-130	-11.784						Z
	-1.591		GRT1{1}	down	1042	0.020	X
	-6.509						Y
-1042	-0.020						Z
	-1.591		GRT2{1}	down	1257	19.527	X
	-6.099						Y
-1257	-19.527						Z

-1.591	GRT3{1}	down	1172	11.803	X
-2.479					Y
					Z
-1172	-11.803				
Tag No.: <None>					
H17	Gravity{1}	up	1	0.000	X
1	0.000				
H17	1 Guide	left	41	0.000	Y
-41	0.000				
Stiff	:RIGID	back		0.027	Z
	-0.027				
	Hydrotest{1}	up	1	0.000	X
1	0.000				
		left	40	0.000	Y
-40	0.000				
		back		0.017	Z
	-0.017				
	Thermal 1{1}	down		0.000	X
	0.000				
		right	7	0.000	Y
7	0.000				

 CIRCUITOPROVABARRE

07/30/2010 CIRCUITO PROVA BARRE
 BENTLEY

02:16 PM

AutoPIPE Plus 9.2.1 RESULT PAGE 31

S U P P O R T F O R C E S

(Force - N , Moment - N.m , Tran. - mm , Rot. - deg)

Point/ B A L	Connect/ Supp. ID	Load Type Combination	L O C A L		G L O	
			Dirn	Force	Deform	Dirn
			back		0.001	Z
		Thermal 2{1}	down		0.000	X
			right	19	0.000	Y
19	0.000		back		18.402	Z
		-18.402				
		Thermal 3{1}	down		0.000	X
			right	8	0.000	Y
8	0.000		back		6.000	Z
		-6.000				
		GRT1{1}	up	1	0.000	X
1	0.000		left	33	0.000	Y

circuitoprovabarre.txt

-33	0.000						
	-0.027		back		0.027	Z	
1	0.000	GRT2{1}	up	1	0.000	X	
-21	0.000		left	21	0.000	Y	
	-18.429		back		18.429	Z	
1	0.000	GRT3{1}	up	1	0.000	X	
-32	0.000		left	32	0.000	Y	
	-6.027		back		6.027	Z	

□

 CIRCUITOPROVABARRE

07/30/2010 CIRCUITO PROVA BARRE
 BENTLEY

02:16 PM

AutoPIPE Plus 9.2.1

RESULT PAGE 32

 R E S T R A I N T R E A C T I O N S

Point) name Z	Load combination Result	FORCES (N)			Result	MOMENTS (N.m)	
		X	Y	Z		X	Y
A22	Guide Tag No.: <None>	[ID: A22 1]					
0	Gravity{1}	-2	135	0	135	0	0
0	Hydrotest{1}	-2	132	0	132	0	0
0	Thermal 1{1}	0	-314	0	314	0	0
0	Thermal 2{1}	0	-245	0	245	0	0
0	Thermal 3{1}	0	-112	0	112	0	0
0	GRT1{1}	-2	-178	0	178	0	0
0	GRT2{1}	-2	-110	0	110	0	0
0	GRT3{1}	-2	24	0	24	0	0
A25	Guide Tag No.: <None>	[ID: A25 1]					
0	Gravity{1}	15	0	-5709	5709	0	0
0	Hydrotest{1}	15	0	-5709	5709	0	0
0	Thermal 1{1}	0	0	153	153	0	0
0	Thermal 2{1}	0	0	131	131	0	0
0	Thermal 3{1}	0	0	3	3	0	0

circuitoprovabarre.txt

0	0						
	GRT1{1}	15	0	-5557	5557	0	0
0	0						
	GRT2{1}	15	0	-5579	5579	0	0
0	0						
	GRT3{1}	15	0	-5706	5706	0	0
0	0						
A26	Guide Tag No.: <None>	[ID: A26	1]				
	Gravity{1}	42	0	-6416	6416	0	0
0	0						
	Hydrotest{1}	42	0	-6414	6414	0	0
0	0						
	Thermal 1{1}	0	0	-5	5	0	0
0	0						
	Thermal 2{1}	0	0	97	97	0	0
0	0						
	Thermal 3{1}	0	0	68	68	0	0
0	0						
	GRT1{1}	42	0	-6421	6421	0	0
0	0						
	GRT2{1}	42	0	-6319	6319	0	0
0	0						
	GRT3{1}	42	0	-6349	6349	0	0
0	0						
B09	Guide Tag No.: <None>	[ID: B09	1]				
	Gravity{1}	-15	11	0	19	0	0
0	0						
	Hydrotest{1}	-15	11	0	18	0	0
0	0						
	Thermal 1{1}	0	-52	0	52	0	0
0	0						
	Thermal 2{1}	0	-61	0	61	0	0
0	0						
	Thermal 3{1}	0	-11	0	11	0	0
0	0						
	GRT1{1}	-15	-41	0	43	0	0
0	0						
	GRT2{1}	-15	-49	0	51	0	0
0	0						
	GRT3{1}	-15	1	0	15	0	0
0	0						
F16	Guide Tag No.: <None>	[ID: F16	1]				
	Gravity{1}	-42	-106	0	114	0	0
0	0						
	Hydrotest{1}	-42	-102	0	111	0	0
0	0						
	Thermal 1{1}	0	358	0	358	0	0
0	0						
	Thermal 2{1}	0	287	0	287	0	0
0	0						
	Thermal 3{1}	0	114	0	114	0	0
0	0						
	GRT1{1}	-42	252	0	255	0	0
0	0						
	GRT2{1}	-42	181	0	185	0	0
0	0						
	GRT3{1}	-42	8	0	43	0	0
0	0						

□

 CIRCUITOPROVABARRE

07/30/2010 CIRCUITO PROVA BARRE

R E S T R A I N T R E A C T I O N S

Point) name Z	Load combination Result	FORCES (N)				MOMENTS (N.m)	
		X	Y	Z	Result	X	Y
H08 M	Spr. Hgr Tag No.: <None> [ID: H08 M1]						
0	Gravity{1}	0	0	-1042	1042	0	0
0	Hydrotest{1}	0	0	-6060	6060	0	0
0	Thermal 1{1}	0	0	0	0	0	0
0	Thermal 2{1}	0	0	-215	215	0	0
0	Thermal 3{1}	0	0	-130	130	0	0
0	GRT1{1}	0	0	-1042	1042	0	0
0	GRT2{1}	0	0	-1257	1257	0	0
0	GRT3{1}	0	0	-1172	1172	0	0
H17	Guide Tag No.: <None> [ID: H17 1]						
0	Gravity{1}	1	-41	0	41	0	0
0	Hydrotest{1}	1	-40	0	40	0	0
0	Thermal 1{1}	0	7	0	7	0	0
0	Thermal 2{1}	0	19	0	19	0	0
0	Thermal 3{1}	0	8	0	8	0	0
0	GRT1{1}	1	-33	0	33	0	0
0	GRT2{1}	1	-21	0	21	0	0
0	GRT3{1}	1	-32	0	32	0	0
H20	Anchor Tag No.: <None>						
0	Gravity{1}	0	0	-975	975	0	0
0	Hydrotest{1}	0	0	4041	4041	0	0
0	Thermal 1{1}	0	0	-147	147	0	0
0	Thermal 2{1}	0	0	-13	13	0	0
0	Thermal 3{1}	0	0	59	59	0	0
0	GRT1{1}	0	0	-1123	1123	0	0
0	GRT2{1}	0	0	-988	988	0	0
0	GRT3{1}	0	0	-916	916	0	0

0 0

□

CIRCUITOPROVABARRE

07/30/2010 CIRCUITO PROVA BARRE
BENTLEY

02:16 PM

AutoPIPE Plus 9.2.1 RESULT PAGE 34

G L O B A L F O R C E S & M O M E N T S

Point) name Z	Load combination Result	FORCES (N)				MOMENTS (N.m)	
		X	Y	Z	Result	X	Y

*** Segment A begin ***

A20	Gravity{1}	0	0	-1275	1275	0	0
0	0						
	Hydrotest{1}	0	0	-1275	1275	0	0
0	0						
	Thermal 1{1}	0	0	0	0	0	0
0	0						
	Thermal 2{1}	0	0	0	0	0	0
0	0						
	Thermal 3{1}	0	0	0	0	0	0
0	0						
	GRT1{1}	0	0	-1275	1275	0	0
0	0						
	GRT2{1}	0	0	-1275	1275	0	0
0	0						
	GRT3{1}	0	0	-1275	1275	0	0
0	0						
A19	Gravity{1}	0	0	-1349	1349	0	0
0	0						
	Hydrotest{1}	0	0	-1349	1349	0	0
0	0						
	Thermal 1{1}	0	0	0	0	0	0
0	0						
	Thermal 2{1}	0	0	0	0	0	0
0	0						
	Thermal 3{1}	0	0	0	0	0	0
0	0						
	GRT1{1}	0	0	-1349	1349	0	0
0	0						
	GRT2{1}	0	0	-1349	1349	0	0
0	0						
	GRT3{1}	0	0	-1349	1349	0	0
0	0						
A18	Gravity{1}	0	0	-1413	1413	0	0
0	0						
	Hydrotest{1}	0	0	-1413	1413	0	0
0	0						
	Thermal 1{1}	0	0	0	0	0	0
0	0						
	Thermal 2{1}	0	0	0	0	0	0
0	0						

circuitoprovabarre.txt

0	Thermal 3{1}	0	0	0	0	0	0
0	GRT1{1}	0	0	-1413	1413	0	0
0	GRT2{1}	0	0	-1413	1413	0	0
0	GRT3{1}	0	0	-1413	1413	0	0
A18	Gravity{1}	0	0	-1787	1787	0	0
0	Hydrotest{1}	0	0	-1787	1787	0	0
0	Thermal 1{1}	0	0	0	0	0	0
0	Thermal 2{1}	0	0	0	0	0	0
0	Thermal 3{1}	0	0	0	0	0	0
0	GRT1{1}	0	0	-1787	1787	0	0
0	GRT2{1}	0	0	-1787	1787	0	0
0	GRT3{1}	0	0	-1787	1787	0	0
A17	Gravity{1}	0	0	-1877	1877	0	0
0	Hydrotest{1}	0	0	-1877	1877	0	0
0	Thermal 1{1}	0	0	0	0	0	0
0	Thermal 2{1}	0	0	0	0	0	0
0	Thermal 3{1}	0	0	0	0	0	0
0	GRT1{1}	0	0	-1877	1877	0	0
0	GRT2{1}	0	0	-1877	1877	0	0
0	GRT3{1}	0	0	-1877	1877	0	0

□

CIRCUITOPROVABARRE

07/30/2010 CIRCUITO PROVA BARRE
BENTLEY

02:16 PM

AutoPIPE Plus 9.2.1 RESULT PAGE 35

G L O B A L F O R C E S & M O M E N T S

Point) name Z	Load combination Result	FORCES (N)				MOMENTS (N.m)	
		X	Y	Z	Result	X	Y
A15	Gravity{1}	0	0	-1886	1886	0	0
0	Hydrotest{1}	0	0	-1886	1886	0	0

circuitoprovabarre.txt

0	0							
	Thermal 1{1}	0	0	0	0	0	0	
0	0							
	Thermal 2{1}	0	0	0	0	0	0	
0	0							
	Thermal 3{1}	0	0	0	0	0	0	
0	0							
	GRT1{1}	0	0	-1886	1886	0	0	
0	0							
	GRT2{1}	0	0	-1886	1886	0	0	
0	0							
	GRT3{1}	0	0	-1886	1886	0	0	
0	0							
A15	+	Gravity{1}	-2	107	-2391	2393	-106	9
2		106						
		Hydrotest{1}	-2	104	-2390	2392	-103	9
2		103						
		Thermal 1{1}	0	-288	99	304	333	0
0		333						
		Thermal 2{1}	0	-225	100	246	271	0
0		271						
		Thermal 3{1}	0	-98	9	98	89	0
0		89						
		GRT1{1}	-2	-180	-2291	2299	227	9
2		228						
		GRT2{1}	-2	-118	-2290	2293	165	9
2		165						
		GRT3{1}	-2	9	-2382	2382	-17	9
2		19						
A16		Gravity{1}	-2	107	-2400	2402	-99	10
2		100						
		Hydrotest{1}	-2	104	-2399	2401	-96	10
2		97						
		Thermal 1{1}	0	-288	99	304	315	0
0		315						
		Thermal 2{1}	0	-225	100	246	256	0
0		256						
		Thermal 3{1}	0	-98	9	98	83	0
0		83						
		GRT1{1}	-2	-180	-2300	2307	216	10
2		216						
		GRT2{1}	-2	-118	-2299	2302	157	10
2		157						
		GRT3{1}	-2	9	-2391	2391	-16	10
2		19						
A22	-	Gravity{1}	-2	107	-2611	2613	62	13
2		63						
		Hydrotest{1}	-2	104	-2611	2613	60	13
2		61						
		Thermal 1{1}	0	-288	99	304	-116	0
0		116						
		Thermal 2{1}	0	-225	100	246	-81	0
0		81						
		Thermal 3{1}	0	-98	9	98	-64	0
0		64						
		GRT1{1}	-2	-180	-2512	2519	-54	13
2		56						
		GRT2{1}	-2	-118	-2511	2514	-19	13
2		24						
		GRT3{1}	-2	9	-2602	2602	-2	13
2		14						
A22	+	Gravity{1}	-1	-28	-2611	2611	62	13
2		63						
		Hydrotest{1}	-1	-28	-2611	2611	60	13

circuitoprovabarre.txt

2	61	Thermal 1{1}	0	26	99	103	-116	0
0	116	Thermal 2{1}	0	20	100	102	-81	0
0	81	Thermal 3{1}	0	14	9	16	-64	0
0	64	GRT1{1}	-1	-2	-2512	2512	-54	13
2	56	GRT2{1}	-1	-8	-2511	2511	-19	13
2	24	GRT3{1}	-1	-14	-2602	2602	-2	13
2	14							

□

CIRCUITOPROVABARRE

07/30/2010 CIRCUITO PROVA BARRE
BENTLEY

02:16 PM

AutoPIPE Plus 9.2.1 RESULT PAGE 36

G L O B A L F O R C E S & M O M E N T S

Point) name Z	Load combination Result	FORCES (N)				MOMENTS (N.m)	
		X	Y	Z	Result	X	Y
A14	- Gravity{1}	-1	-28	-3172	3172	-50	16
2	52 Hydrotest{1}	-1	-28	-3171	3171	-50	16
2	53 Thermal 1{1}	0	26	99	103	-13	0
0	13 Thermal 2{1}	0	20	100	102	0	0
0	0 Thermal 3{1}	0	14	9	16	-9	0
0	9 GRT1{1}	-1	-2	-3072	3072	-62	16
2	64 GRT2{1}	-1	-8	-3071	3071	-50	16
2	53 GRT3{1}	-1	-14	-3163	3163	-59	16
2	61						
A14	+ Gravity{1}	-1	-28	-3546	3546	-50	16
2	52 Hydrotest{1}	-1	-28	-3546	3546	-50	16
2	53 Thermal 1{1}	0	26	99	103	-13	0
0	13 Thermal 2{1}	0	20	100	102	0	0
0	0 Thermal 3{1}	0	14	9	16	-9	0
0	9 GRT1{1}	-1	-2	-3447	3447	-62	16
2	64 GRT2{1}	-1	-8	-3446	3446	-50	16
2	53 GRT3{1}	-1	-14	-3537	3537	-59	16

circuitoprovabarre.txt

2	61							
A04	-	Gravity{1}	-1	-28	-3891	3891	-118	18
2		120						
		Hydrotest{1}	-1	-28	-3891	3891	-118	18
2		119						
		Thermal 1{1}	0	26	99	103	51	0
0		51						
		Thermal 2{1}	0	20	100	102	50	0
0		50						
		Thermal 3{1}	0	14	9	16	24	0
0		24						
		GRT1{1}	-1	-2	-3792	3792	-67	18
2		69						
		GRT2{1}	-1	-8	-3791	3791	-69	18
2		71						
		GRT3{1}	-1	-14	-3882	3882	-94	18
2		96						
A04	+	Gravity{1}	-1	-28	-4266	4266	-118	18
2		120						
		Hydrotest{1}	-1	-28	-4265	4265	-118	18
2		119						
		Thermal 1{1}	0	26	99	103	51	0
0		51						
		Thermal 2{1}	0	20	100	102	50	0
0		50						
		Thermal 3{1}	0	14	9	16	24	0
0		24						
		GRT1{1}	-1	-2	-4167	4167	-67	18
2		69						
		GRT2{1}	-1	-8	-4166	4166	-69	18
2		71						
		GRT3{1}	-1	-14	-4257	4257	-94	18
2		96						
A03	N	Gravity{1}	-1	-28	-4295	4295	-124	18
2		125						
		Hydrotest{1}	-1	-28	-4295	4295	-123	18
2		125						
		Thermal 1{1}	0	26	99	103	57	0
0		57						
		Thermal 2{1}	0	20	100	102	54	0
0		54						
		Thermal 3{1}	0	14	9	16	27	0
0		27						
		GRT1{1}	-1	-2	-4196	4196	-67	18
2		70						
		GRT2{1}	-1	-8	-4195	4195	-70	18
2		73						
		GRT3{1}	-1	-14	-4286	4286	-97	18
2		99						

□

 CIRCUITOPROVABARRE

07/30/2010 CIRCUITO PROVA BARRE
 BENTLEY

02:16 PM

AutoPIPE Plus 9.2.1

RESULT PAGE 37

 G L O B A L F O R C E S & M O M E N T S

circuitoprovabarre.txt

Point) name Z	Load combination Result	FORCES (N)				MOMENTS (N.m)	
		X	Y	Z	Result	X	Y
A03 M 2	Gravity{1} 34	-1	-28	-4304	4304	-29	18
2	Hydrotest{1} 34	-1	-28	-4303	4303	-28	18
0	Thermal 1{1} 56	0	26	99	103	56	0
0	Thermal 2{1} 53	0	20	100	102	53	0
0	Thermal 3{1} 28	0	14	9	16	28	0
2	GRT1{1} 33	-1	-2	-4204	4204	27	18
2	GRT2{1} 30	-1	-8	-4203	4203	24	18
2	GRT3{1} 18	-1	-14	-4295	4295	-1	18
A03 F 2	Gravity{1} 202	-1	-28	-4312	4312	201	18
2	Hydrotest{1} 202	-1	-28	-4312	4312	202	18
0	Thermal 1{1} 51	0	26	99	103	51	0
0	Thermal 2{1} 48	0	20	100	102	48	0
0	Thermal 3{1} 27	0	14	9	16	27	0
2	GRT1{1} 253	-1	-2	-4213	4213	252	18
2	GRT2{1} 249	-1	-8	-4212	4212	248	18
2	GRT3{1} 229	-1	-14	-4303	4303	228	18
A00 2	Gravity{1} 204	-1	-28	-4312	4312	203	18
2	Hydrotest{1} 205	-1	-28	-4312	4312	204	18
0	Thermal 1{1} 51	0	26	99	103	51	0
0	Thermal 2{1} 48	0	20	100	102	48	0
0	Thermal 3{1} 27	0	14	9	16	27	0
2	GRT1{1} 255	-1	-2	-4213	4213	255	18
2	GRT2{1} 252	-1	-8	-4212	4212	251	18
2	GRT3{1} 232	-1	-14	-4303	4303	231	18
A25 2	Gravity{1} 315	-1	-28	-4316	4316	315	18
2	Hydrotest{1} 316	-1	-28	-4315	4315	316	18
0	Thermal 1{1} 49	0	26	99	103	49	0
0	Thermal 2{1} 45	0	20	100	102	45	0
0	Thermal 3{1} 27	0	14	9	16	27	0

circuitoprovabarre.txt

2	GRT1{1}	-1	-2	-4217	4217	363	18	
	364							
2	GRT2{1}	-1	-8	-4215	4215	360	18	
	360							
2	GRT3{1}	-1	-14	-4307	4307	342	18	
	342							
A25	+	Gravity{1}	-15	-28	1393	1394	315	18
2		315						
2		Hydrotest{1}	-15	-28	1393	1394	316	18
		316						
0		Thermal 1{1}	0	26	-53	59	49	0
		49						
0		Thermal 2{1}	0	20	-30	36	45	0
		45						
0		Thermal 3{1}	0	14	6	15	27	0
		27						
2		GRT1{1}	-15	-2	1340	1340	363	18
		364						
2		GRT2{1}	-15	-8	1363	1363	360	18
		360						
2		GRT3{1}	-15	-14	1399	1399	342	18
		342						

□

CIRCUITOPROVABARRE

07/30/2010 CIRCUITO PROVA BARRE
BENTLEY

02:16 PM

AutoPIPE Plus 9.2.1

RESULT PAGE 38

G L O B A L F O R C E S & M O M E N T S

Point) name Z	Load combination Result	FORCES (N)				MOMENTS (N.m)		
		X	Y	Z	Result	X	Y	
A01	- Gravity{1}	-15	-28	1388	1388	262	18	
2	263							
2	Hydrotest{1}	-15	-28	1388	1388	263	18	
	264							
0	Thermal 1{1}	0	26	-53	59	51	0	
	51							
0	Thermal 2{1}	0	20	-30	36	46	0	
	46							
0	Thermal 3{1}	0	14	6	15	27	0	
	27							
2	GRT1{1}	-15	-2	1335	1335	313	18	
	313							
2	GRT2{1}	-15	-8	1358	1358	309	18	
	309							
2	GRT3{1}	-15	-14	1394	1394	289	18	
	290							
A01	+	Gravity{1}	-1	-40	22	45	206	33
2		208						
2		Hydrotest{1}	-1	-39	22	44	206	33
		209						
		Thermal 1{1}	0	78	-53	95	-1	0

circuitoprovabarre.txt

0	1						
0	Thermal 2{1}	0	81	-30	87	-13	0
	13						
0	Thermal 3{1}	0	24	6	25	16	0
	16						
0	GRT1{1}	-1	39	-32	50	205	33
2	208						
2	GRT2{1}	-1	42	-9	43	193	33
	195						
2	GRT3{1}	-1	-15	27	31	222	33
	225						
A05	Gravity{1}	-1	-40	-212	216	364	33
1	365						
	Hydrotest{1}	-1	-39	-212	216	364	33
1	366						
0	Thermal 1{1}	0	78	-53	95	88	0
	88						
0	Thermal 2{1}	0	81	-30	87	37	0
	37						
0	Thermal 3{1}	0	24	6	25	7	0
	7						
1	GRT1{1}	-1	39	-266	268	452	33
	453						
1	GRT2{1}	-1	42	-242	246	400	33
	402						
1	GRT3{1}	-1	-15	-207	207	371	33
	372						
A07	- Gravity{1}	-1	-40	-221	225	378	33
1	379						
	Hydrotest{1}	-1	-39	-221	225	378	33
1	379						
0	Thermal 1{1}	0	78	-53	95	91	0
	91						
0	Thermal 2{1}	0	81	-30	87	38	0
	38						
0	Thermal 3{1}	0	24	6	25	7	0
	7						
1	GRT1{1}	-1	39	-274	277	469	33
	470						
1	GRT2{1}	-1	42	-251	255	416	33
	417						
1	GRT3{1}	-1	-15	-215	216	384	33
	386						
A07	+ Gravity{1}	-1	-40	-225	228	378	33
1	379						
	Hydrotest{1}	-1	-39	-225	228	378	33
1	379						
0	Thermal 1{1}	0	78	-53	95	91	0
	91						
0	Thermal 2{1}	0	81	-30	87	38	0
	38						
0	Thermal 3{1}	0	24	6	25	7	0
	7						
1	GRT1{1}	-1	39	-278	281	469	33
	470						
1	GRT2{1}	-1	42	-255	258	416	33
	417						
1	GRT3{1}	-1	-15	-219	219	384	33
	386						

□

CIRCUITOPROVABARRE

G L O B A L F O R C E S & M O M E N T S

Point) name Z	Load combination Result	FORCES (N)				MOMENTS (N.m)	
		X	Y	Z	Result	X	Y
A26 1	- Gravity{1} 388	-1	-40	-230	233	386	33
1	Hydrotest{1} 388	-1	-39	-230	233	387	33
0	Thermal 1{1} 93	0	78	-53	95	93	0
0	Thermal 2{1} 40	0	81	-30	87	40	0
0	Thermal 3{1} 6	0	24	6	25	6	0
1	GRT1{1} 480	-1	39	-283	286	479	33
1	GRT2{1} 427	-1	42	-260	263	426	33
1	GRT3{1} 394	-1	-15	-224	225	393	33
A26 1	+ Gravity{1} 388	-43	-40	6186	6186	386	33
1	Hydrotest{1} 388	-43	-39	6184	6184	387	33
0	Thermal 1{1} 93	0	78	-48	92	93	0
0	Thermal 2{1} 40	0	81	-128	151	40	0
0	Thermal 3{1} 6	0	24	-62	66	6	0
1	GRT1{1} 480	-43	39	6138	6138	479	33
1	GRT2{1} 427	-43	42	6059	6059	426	33
1	GRT3{1} 394	-43	-15	6124	6124	393	33
A08 -1	Gravity{1} 229	-43	-40	6182	6183	227	33
-1	Hydrotest{1} 229	-43	-39	6181	6181	227	33
0	Thermal 1{1} 94	0	78	-48	92	94	0
0	Thermal 2{1} 43	0	81	-128	151	43	0
0	Thermal 3{1} 8	0	24	-62	66	8	0
-1	GRT1{1} 323	-43	39	6134	6135	321	33
-1	GRT2{1} 272	-43	42	6055	6055	270	33
-1	GRT3{1} 237	-43	-15	6121	6121	235	33

circuitoprovabarre.txt

A09 N	Gravity{1}	-43	-40	6182	6183	223	33
-1	225						
-1	Hydrotest{1}	-43	-39	6180	6181	223	33
	225						
0	Thermal 1{1}	0	78	-48	92	94	0
	94						
0	Thermal 2{1}	0	81	-128	151	43	0
	43						
0	Thermal 3{1}	0	24	-62	66	8	0
	8						
-1	GRT1{1}	-43	39	6134	6134	317	33
	319						
-1	GRT2{1}	-43	42	6055	6055	266	33
	268						
-1	GRT3{1}	-43	-15	6121	6121	231	33
	233						
A09 M	Gravity{1}	-43	-40	6174	6174	-105	32
-3	110						
-3	Hydrotest{1}	-43	-39	6172	6172	-105	32
	110						
0	Thermal 1{1}	0	78	-48	92	95	0
	95						
0	Thermal 2{1}	0	81	-128	151	48	0
	48						
0	Thermal 3{1}	0	24	-62	66	11	0
	11						
-3	GRT1{1}	-43	39	6126	6126	-10	32
	33						
-3	GRT2{1}	-43	42	6046	6047	-57	32
	66						
-3	GRT3{1}	-43	-15	6112	6112	-95	32
	100						

□

CIRCUITOPROVABARRE

07/30/2010 CIRCUITO PROVA BARRE
BENTLEY

02:16 PM

AutoPIPE Plus 9.2.1

RESULT PAGE 40

G L O B A L F O R C E S & M O M E N T S

Point) name Z	Load combination Result	FORCES (N)				MOMENTS (N.m)	
		X	Y	Z	Result	X	Y
A09 F	Gravity{1}	-43	-40	6166	6166	-241	29
-4	243						
-4	Hydrotest{1}	-43	-39	6164	6164	-241	29
	242						
0	Thermal 1{1}	0	78	-48	92	92	0
	92						
0	Thermal 2{1}	0	81	-128	151	46	0
	46						
0	Thermal 3{1}	0	24	-62	66	11	0
	11						
-4	GRT1{1}	-43	39	6117	6118	-149	29
	152						

circuitoprovabarre.txt

-4	GRT2{1}	-43	42	6038	6038	-194	29
	197						
-4	GRT3{1}	-43	-15	6104	6104	-230	29
	232						
A11	Gravity{1}	-43	-40	6166	6166	-241	29
-4	243						
-4	Hydrotest{1}	-43	-39	6164	6164	-241	29
	242						
0	Thermal 1{1}	0	78	-48	92	92	0
	92						
0	Thermal 2{1}	0	81	-128	151	46	0
	46						
0	Thermal 3{1}	0	24	-62	66	11	0
	11						
-4	GRT1{1}	-43	39	6117	6118	-149	29
	152						
-4	GRT2{1}	-43	42	6038	6038	-195	29
	197						
-4	GRT3{1}	-43	-15	6104	6104	-230	29
	232						
A10	- Gravity{1}	-43	-40	6157	6157	-238	27
-4	240						
-4	Hydrotest{1}	-43	-39	6155	6155	-238	27
	240						
0	Thermal 1{1}	0	78	-48	92	87	0
	87						
0	Thermal 2{1}	0	81	-128	151	41	0
	41						
0	Thermal 3{1}	0	24	-62	66	9	0
	9						
-4	GRT1{1}	-43	39	6108	6109	-151	27
	154						
-4	GRT2{1}	-43	42	6029	6029	-197	27
	199						
-4	GRT3{1}	-43	-15	6095	6095	-229	27
	231						
A10	+ Gravity{1}	-44	-32	6256	6256	-147	32
-3	151						
-3	Hydrotest{1}	-44	-31	6256	6256	-146	32
	149						
0	Thermal 1{1}	0	69	85	110	164	0
	164						
0	Thermal 2{1}	0	65	94	114	166	0
	166						
0	Thermal 3{1}	0	18	9	20	48	0
	48						
-3	GRT1{1}	-44	37	6340	6341	17	32
	37						
-3	GRT2{1}	-44	32	6349	6350	19	32
	38						
-3	GRT3{1}	-44	-14	6264	6265	-99	32
	104						
A12	Gravity{1}	-44	-32	6247	6247	-145	30
-3	148						
-3	Hydrotest{1}	-44	-31	6247	6247	-144	30
	147						
0	Thermal 1{1}	0	69	85	110	160	0
	160						
0	Thermal 2{1}	0	65	94	114	162	0
	162						
0	Thermal 3{1}	0	18	9	20	47	0
	47						
-3	GRT1{1}	-44	37	6331	6332	15	30
	33						

circuitoprovabarre.txt

-3	GRT2{1}	-44	32	6340	6341	17	30
	34						
-3	GRT3{1}	-44	-14	6256	6256	-98	30
	102						

□

CIRCUITOPROVABARRE

07/30/2010 CIRCUITO PROVA BARRE
BENTLEY

02:16 PM

AutoPIPE Plus 9.2.1 RESULT PAGE 41

G L O B A L F O R C E S & M O M E N T S

Point) name Z	Load combination Result	FORCES (N)				MOMENTS (N.m)	
		X	Y	Z	Result	X	Y
A13	Gravity{1}	-44	-32	6229	6229	-141	24
-3	143						
-3	Hydrotest{1}	-44	-31	6229	6229	-140	24
	142						
0	Thermal 1{1}	0	69	85	110	151	0
	151						
0	Thermal 2{1}	0	65	94	114	154	0
	154						
0	Thermal 3{1}	0	18	9	20	45	0
	45						
-3	GRT1{1}	-44	37	6313	6314	10	24
	26						
-3	GRT2{1}	-44	32	6322	6323	13	24
	27						
-3	GRT3{1}	-44	-14	6238	6238	-96	24
	99						

*** Segment A end ***

*** Segment B begin ***

A01	Gravity{1}	-15	11	1366	1367	56	-15
0	58						
0	Hydrotest{1}	-15	11	1366	1367	57	-15
	59						
0	Thermal 1{1}	0	-52	0	52	51	0
	51						
0	Thermal 2{1}	0	-61	0	61	60	0
	60						
0	Thermal 3{1}	0	-11	0	11	11	0
	11						
0	GRT1{1}	-15	-41	1366	1367	108	-15
	109						
0	GRT2{1}	-15	-49	1366	1367	116	-15
	117						
0	GRT3{1}	-15	1	1366	1367	67	-15
	68						
B01	Gravity{1}	-15	11	1361	1362	58	-13
0	59						
0	Hydrotest{1}	-15	11	1361	1362	58	-13

circuitoprovabarre.txt

0	60						
	Thermal 1{1}	0	-52	0	52	45	0
0	45						
	Thermal 2{1}	0	-61	0	61	52	0
0	52						
	Thermal 3{1}	0	-11	0	11	9	0
0	9						
	GRT1{1}	-15	-41	1361	1362	103	-13
0	103						
	GRT2{1}	-15	-49	1361	1362	110	-13
0	111						
	GRT3{1}	-15	1	1361	1361	67	-13
0	68						
B01	+ Gravity{1}	-15	11	1281	1281	58	-13
0	59						
	Hydrotest{1}	-15	11	1281	1281	58	-13
0	60						
	Thermal 1{1}	0	-52	0	52	45	0
0	45						
	Thermal 2{1}	0	-61	0	61	52	0
0	52						
	Thermal 3{1}	0	-11	0	11	9	0
0	9						
	GRT1{1}	-15	-41	1281	1282	103	-13
0	103						
	GRT2{1}	-15	-49	1281	1282	110	-13
0	111						
	GRT3{1}	-15	1	1281	1281	67	-13
0	68						
B02	Gravity{1}	-15	11	1277	1277	59	-11
0	60						
	Hydrotest{1}	-15	11	1277	1277	59	-11
0	60						
	Thermal 1{1}	0	-52	0	52	40	0
0	40						
	Thermal 2{1}	0	-61	0	61	47	0
0	47						
	Thermal 3{1}	0	-11	0	11	8	0
0	8						
	GRT1{1}	-15	-41	1277	1278	99	-11
0	100						
	GRT2{1}	-15	-49	1277	1278	106	-11
0	106						
	GRT3{1}	-15	1	1277	1277	67	-11
0	68						

□

 CIRCUITOPROVABARRE

07/30/2010 CIRCUITO PROVA BARRE
 BENTLEY

02:16 PM

AutoPIPE Plus 9.2.1 RESULT PAGE 42

G L O B A L F O R C E S & M O M E N T S

Point) name Z	Load combination Result	FORCES (N)			MOMENTS (N.m)	
		X	Y	Z	Result	X

circuitoprovabarre.txt

B03	Gravity{1}	-15	11	1273	1273	60	-10
0	60						
	Hydrotest{1}	-15	11	1273	1273	60	-10
0	61						
	Thermal 1{1}	0	-52	0	52	37	0
0	37						
	Thermal 2{1}	0	-61	0	61	43	0
0	43						
	Thermal 3{1}	0	-11	0	11	8	0
0	8						
	GRT1{1}	-15	-41	1273	1274	96	-10
0	97						
	GRT2{1}	-15	-49	1273	1274	102	-10
0	103						
	GRT3{1}	-15	1	1273	1273	67	-10
0	68						
B04	Gravity{1}	-15	11	1260	1260	61	-9
0	61						
	Hydrotest{1}	-15	11	1260	1260	61	-9
0	62						
	Thermal 1{1}	0	-52	0	52	32	0
0	32						
	Thermal 2{1}	0	-61	0	61	37	0
0	37						
	Thermal 3{1}	0	-11	0	11	7	0
0	7						
	GRT1{1}	-15	-41	1260	1261	93	-9
0	93						
	GRT2{1}	-15	-49	1260	1261	98	-9
0	98						
	GRT3{1}	-15	1	1260	1260	67	-9
0	68						
B09	- Gravity{1}	-15	11	1144	1144	68	0
0	68						
	Hydrotest{1}	-15	11	1144	1144	68	0
0	68						
	Thermal 1{1}	0	-52	0	52	0	0
0	0						
	Thermal 2{1}	0	-61	0	61	0	0
0	0						
	Thermal 3{1}	0	-11	0	11	0	0
0	0						
	GRT1{1}	-15	-41	1144	1144	68	0
0	68						
	GRT2{1}	-15	-49	1144	1145	68	0
0	68						
	GRT3{1}	-15	1	1144	1144	68	0
0	68						
B09	+ Gravity{1}	0	0	1144	1144	68	0
0	68						
	Hydrotest{1}	0	0	1144	1144	68	0
0	68						
	Thermal 1{1}	0	0	0	0	0	0
0	0						
	Thermal 2{1}	0	0	0	0	0	0
0	0						
	Thermal 3{1}	0	0	0	0	0	0
0	0						
	GRT1{1}	0	0	1144	1144	68	0
0	68						
	GRT2{1}	0	0	1144	1144	68	0
0	68						
	GRT3{1}	0	0	1144	1144	68	0
0	68						

circuitoprovabarre.txt

0	68							
B05	-	Gravity{1}	0	0	447	447	68	0
0		68						
		Hydrotest{1}	0	0	447	447	68	0
0		68						
		Thermal 1{1}	0	0	0	0	0	0
0		0						
		Thermal 2{1}	0	0	0	0	0	0
0		0						
		Thermal 3{1}	0	0	0	0	0	0
0		0						
		GRT1{1}	0	0	447	447	68	0
0		68						
		GRT2{1}	0	0	447	447	68	0
0		68						
		GRT3{1}	0	0	447	447	68	0
0		68						

□

CIRCUITOPROVABARRE

07/30/2010 CIRCUITO PROVA BARRE
BENTLEY

02:16 PM

AutoPIPE Plus 9.2.1 RESULT PAGE 43

G L O B A L F O R C E S & M O M E N T S

Point) name Z	Load combination Result	FORCES (N)				MOMENTS (N.m)		
		X	Y	Z	Result	X	Y	
B05	+	Gravity{1}	0	0	303	303	0	0
0		0						
		Hydrotest{1}	0	0	303	303	0	0
0		0						
		Thermal 1{1}	0	0	0	0	0	0
0		0						
		Thermal 2{1}	0	0	0	0	0	0
0		0						
		Thermal 3{1}	0	0	0	0	0	0
0		0						
		GRT1{1}	0	0	303	303	0	0
0		0						
		GRT2{1}	0	0	303	303	0	0
0		0						
		GRT3{1}	0	0	303	303	0	0
0		0						
B10		Gravity{1}	0	0	291	291	0	0
0		0						
		Hydrotest{1}	0	0	291	291	0	0
0		0						
		Thermal 1{1}	0	0	0	0	0	0
0		0						
		Thermal 2{1}	0	0	0	0	0	0
0		0						
		Thermal 3{1}	0	0	0	0	0	0
0		0						

circuitoprovabarre.txt

0	GRT1{1}	0	0	291	291	0	0
0	0						
0	GRT2{1}	0	0	291	291	0	0
0	0						
0	GRT3{1}	0	0	291	291	0	0
0	0						
B06	Gravity{1}	0	0	278	278	0	0
0	0						
0	Hydrotest{1}	0	0	278	278	0	0
0	0						
0	Thermal 1{1}	0	0	0	0	0	0
0	0						
0	Thermal 2{1}	0	0	0	0	0	0
0	0						
0	Thermal 3{1}	0	0	0	0	0	0
0	0						
0	GRT1{1}	0	0	278	278	0	0
0	0						
0	GRT2{1}	0	0	278	278	0	0
0	0						
0	GRT3{1}	0	0	278	278	0	0
0	0						
B07	Gravity{1}	0	0	268	268	0	0
0	0						
0	Hydrotest{1}	0	0	268	268	0	0
0	0						
0	Thermal 1{1}	0	0	0	0	0	0
0	0						
0	Thermal 2{1}	0	0	0	0	0	0
0	0						
0	Thermal 3{1}	0	0	0	0	0	0
0	0						
0	GRT1{1}	0	0	268	268	0	0
0	0						
0	GRT2{1}	0	0	268	268	0	0
0	0						
0	GRT3{1}	0	0	268	268	0	0
0	0						
B08	Gravity{1}	0	0	258	258	0	0
0	0						
0	Hydrotest{1}	0	0	258	258	0	0
0	0						
0	Thermal 1{1}	0	0	0	0	0	0
0	0						
0	Thermal 2{1}	0	0	0	0	0	0
0	0						
0	Thermal 3{1}	0	0	0	0	0	0
0	0						
0	GRT1{1}	0	0	258	258	0	0
0	0						
0	GRT2{1}	0	0	258	258	0	0
0	0						
0	GRT3{1}	0	0	258	258	0	0
0	0						

*** Segment B end ***

*** Segment C begin ***

□

 CIRCUITOPROVABARRE

07/30/2010 CIRCUITO PROVA BARRE

G L O B A L F O R C E S & M O M E N T S

Point) name Z	Load combination Result	FORCES (N)				MOMENTS (N.m)	
		X	Y	Z	Result	X	Y
A07	Gravity{1}	0	0	3	3	0	0
0	0						
	Hydrotest{1}	0	0	3	3	0	0
0	0						
	Thermal 1{1}	0	0	0	0	0	0
0	0						
	Thermal 2{1}	0	0	0	0	0	0
0	0						
	Thermal 3{1}	0	0	0	0	0	0
0	0						
	GRT1{1}	0	0	3	3	0	0
0	0						
	GRT2{1}	0	0	3	3	0	0
0	0						
	GRT3{1}	0	0	3	3	0	0
0	0						
C01	Gravity{1}	0	0	0	0	0	0
0	0						
	Hydrotest{1}	0	0	0	0	0	0
0	0						
	Thermal 1{1}	0	0	0	0	0	0
0	0						
	Thermal 2{1}	0	0	0	0	0	0
0	0						
	Thermal 3{1}	0	0	0	0	0	0
0	0						
	GRT1{1}	0	0	0	0	0	0
0	0						
	GRT2{1}	0	0	0	0	0	0
0	0						
	GRT3{1}	0	0	0	0	0	0
0	0						

*** Segment C end ***

*** Segment D begin ***

A10	Gravity{1}	1	-8	-99	99	-91	-6
-1	91						
	Hydrotest{1}	1	-7	-101	102	-93	-6
-1	93						
	Thermal 1{1}	0	9	-133	133	-77	0
0	77						
	Thermal 2{1}	0	17	-221	222	-125	0
0	125						
	Thermal 3{1}	0	6	-71	71	-39	0
0	39						
	GRT1{1}	1	1	-232	232	-168	-6
-1	168						
	GRT2{1}	1	9	-320	320	-216	-6
-1	216						

circuitoprovabarre.txt

-1	GRT3{1}	1	-1	-170	170	-130	-6
	130						
D01	Gravity{1}	1	-8	-101	101	-86	-6
-1	86						
-1	Hydrotest{1}	1	-7	-103	103	-87	-6
	88						
0	Thermal 1{1}	0	9	-133	133	-70	0
	70						
0	Thermal 2{1}	0	17	-221	222	-114	0
	114						
0	Thermal 3{1}	0	6	-71	71	-35	0
	35						
-1	GRT1{1}	1	1	-234	234	-156	-6
	157						
-1	GRT2{1}	1	9	-322	322	-200	-6
	200						
-1	GRT3{1}	1	-1	-172	172	-121	-6
	122						
D08	Gravity{1}	1	-8	-103	103	-81	-6
-1	81						
-1	Hydrotest{1}	1	-7	-105	105	-82	-6
	82						
0	Thermal 1{1}	0	9	-133	133	-64	0
	64						
0	Thermal 2{1}	0	17	-221	222	-103	0
	103						
0	Thermal 3{1}	0	6	-71	71	-32	0
	32						
-1	GRT1{1}	1	1	-236	236	-145	-6
	145						
-1	GRT2{1}	1	9	-324	324	-184	-6
	184						
-1	GRT3{1}	1	-1	-173	173	-113	-6
	113						

□

CIRCUITOPROVABARRE

07/30/2010 CIRCUITO PROVA BARRE
BENTLEY

02:16 PM

AutoPIPE Plus 9.2.1 RESULT PAGE 45

G L O B A L F O R C E S & M O M E N T S

Point) name Z	Load combination Result	FORCES (N)				MOMENTS (N.m)	
		X	Y	Z	Result	X	Y
D02	Gravity{1}	1	-8	-123	124	-17	-6
0	18						
0	Hydrotest{1}	1	-7	-126	126	-17	-6
	18						
0	Thermal 1{1}	0	9	-133	133	12	0
	12						
0	Thermal 2{1}	0	17	-221	222	23	0
	23						
0	Thermal 3{1}	0	6	-71	71	8	0

circuitprovabarre.txt

0	8						
0	GRT1{1}	1	1	-256	256	-6	-6
0	8						
0	GRT2{1}	1	9	-345	345	5	-6
0	8						
0	GRT3{1}	1	-1	-194	194	-9	-6
0	11						
D03	- Gravity{1}	1	-8	-125	125	-12	-6
0	14						
0	Hydrotest{1}	1	-7	-127	127	-12	-6
0	13						
0	Thermal 1{1}	0	9	-133	133	17	0
0	17						
0	Thermal 2{1}	0	17	-221	222	31	0
0	31						
0	Thermal 3{1}	0	6	-71	71	11	0
0	11						
0	GRT1{1}	1	1	-258	258	4	-6
0	7						
0	GRT2{1}	1	9	-346	346	19	-6
0	19						
0	GRT3{1}	1	-1	-195	195	-2	-6
0	6						
D03	+ Gravity{1}	1	-8	-128	128	-12	-6
0	14						
0	Hydrotest{1}	1	-7	-130	130	-12	-6
0	13						
0	Thermal 1{1}	0	9	-133	133	17	0
0	17						
0	Thermal 2{1}	0	17	-221	222	31	0
0	31						
0	Thermal 3{1}	0	6	-71	71	11	0
0	11						
0	GRT1{1}	1	1	-261	261	4	-6
0	7						
0	GRT2{1}	1	9	-349	349	19	-6
0	19						
0	GRT3{1}	1	-1	-198	198	-2	-6
0	6						
D04	Gravity{1}	1	-8	-129	129	-8	-6
0	9						
0	Hydrotest{1}	1	-7	-131	132	-7	-6
0	9						
0	Thermal 1{1}	0	9	-133	133	22	0
0	22						
0	Thermal 2{1}	0	17	-221	222	40	0
0	40						
0	Thermal 3{1}	0	6	-71	71	14	0
0	14						
0	GRT1{1}	1	1	-262	262	14	-6
0	15						
0	GRT2{1}	1	9	-350	350	32	-6
0	32						
0	GRT3{1}	1	-1	-200	200	6	-6
0	8						
D05	N Gravity{1}	1	-8	-129	129	-7	-6
0	9						
0	Hydrotest{1}	1	-7	-131	132	-7	-6
0	9						
0	Thermal 1{1}	0	9	-133	133	22	0
0	22						
0	Thermal 2{1}	0	17	-221	222	40	0
0	40						
0	Thermal 3{1}	0	6	-71	71	14	0

circuitoprovabarre.txt

0	14						
	GRT1{1}	1	1	-262	262	14	-6
0	15						
	GRT2{1}	1	9	-350	350	32	-6
0	33						
	GRT3{1}	1	-1	-200	200	6	-6
0	8						

□

CIRCUITOPROVABARRE

07/30/2010 CIRCUITO PROVA BARRE
BENTLEY

02:16 PM

AutoPIPE Plus 9.2.1 RESULT PAGE 46

G L O B A L F O R C E S & M O M E N T S

Point) name Z	Load combination Result	FORCES (N)				MOMENTS (N.m)	
		X	Y	Z	Result	X	Y
D05 M	Gravity{1}	1	-8	-130	130	-4	-6
0	7						
	Hydrotest{1}	1	-7	-132	133	-4	-6
0	7						
	Thermal 1{1}	0	9	-133	133	25	0
0	25						
	Thermal 2{1}	0	17	-221	222	45	0
0	45						
	Thermal 3{1}	0	6	-71	71	15	0
0	15						
	GRT1{1}	1	1	-263	263	21	-6
0	22						
	GRT2{1}	1	9	-351	352	41	-6
0	42						
	GRT3{1}	1	-1	-201	201	11	-6
0	13						
D05 F	Gravity{1}	1	-8	-131	131	-2	-6
0	6						
	Hydrotest{1}	1	-7	-134	134	-2	-6
0	6						
	Thermal 1{1}	0	9	-133	133	26	0
0	26						
	Thermal 2{1}	0	17	-221	222	47	0
0	47						
	Thermal 3{1}	0	6	-71	71	16	0
0	16						
	GRT1{1}	1	1	-264	264	24	-6
0	25						
	GRT2{1}	1	9	-353	353	45	-6
0	45						
	GRT3{1}	1	-1	-202	202	14	-6
0	15						
D06	Gravity{1}	1	-8	-131	131	-2	-6
0	6						
	Hydrotest{1}	1	-7	-134	134	-2	-6
0	6						

circuitoprovabarre.txt

0	Thermal 1{1}	0	9	-133	133	26	0
0	26						
0	Thermal 2{1}	0	17	-221	222	47	0
0	47						
0	Thermal 3{1}	0	6	-71	71	16	0
0	16						
0	GRT1{1}	1	1	-264	264	24	-6
0	25						
0	GRT2{1}	1	9	-353	353	45	-6
0	45						
0	GRT3{1}	1	-1	-202	202	14	-6
0	15						
D07	Gravity{1}	1	-8	-135	135	-2	-5
0	6						
0	Hydrotest{1}	1	-7	-137	137	-1	-5
0	6						
0	Thermal 1{1}	0	9	-133	133	26	0
0	26						
0	Thermal 2{1}	0	17	-221	222	46	0
0	46						
0	Thermal 3{1}	0	6	-71	71	15	0
0	15						
0	GRT1{1}	1	1	-268	268	24	-5
0	25						
0	GRT2{1}	1	9	-356	356	44	-5
0	44						
0	GRT3{1}	1	-1	-205	205	14	-5
0	15						

*** Segment D end ***

*** Segment F begin ***

A15	Gravity{1}	2	-107	505	516	106	-9
-2	106						
-2	Hydrotest{1}	2	-104	504	515	103	-9
-2	103						
0	Thermal 1{1}	0	288	-99	304	-333	0
0	333						
0	Thermal 2{1}	0	225	-100	246	-271	0
0	271						
0	Thermal 3{1}	0	98	-9	98	-89	0
0	89						
-2	GRT1{1}	2	180	405	444	-227	-9
-2	228						
-2	GRT2{1}	2	118	404	421	-165	-9
-2	165						
-2	GRT3{1}	2	-9	496	496	17	-9
-2	19						

□

CIRCUITOPROVABARRE

07/30/2010 CIRCUITO PROVA BARRE
BENTLEY

02:16 PM

AutoPIPE Plus 9.2.1 RESULT PAGE 47

G L O B A L F O R C E S & M O M E N T S

Point Load FORCES (N) MOMENTS (N.m)

circuitoprovabarre.txt

) name Z	combination Result	X	Y	Z	Result	X	Y
F01	Gravity{1}	2	-107	496	507	74	-9
-2	75						
	Hydrotest{1}	2	-104	495	506	71	-9
-2	72						
	Thermal 1{1}	0	288	-99	304	-327	0
0	327						
	Thermal 2{1}	0	225	-100	246	-264	0
0	264						
	Thermal 3{1}	0	98	-9	98	-89	0
0	89						
	GRT1{1}	2	180	396	436	-253	-9
-2	253						
	GRT2{1}	2	118	395	412	-190	-9
-2	190						
	GRT3{1}	2	-9	487	487	-15	-9
-2	18						
F02	- Gravity{1}	2	-107	462	474	-41	-9
-2	42						
	Hydrotest{1}	2	-104	461	473	-44	-9
-2	45						
	Thermal 1{1}	0	288	-99	304	-303	0
0	303						
	Thermal 2{1}	0	225	-100	246	-240	0
0	240						
	Thermal 3{1}	0	98	-9	98	-87	0
0	87						
	GRT1{1}	2	180	363	405	-344	-9
-2	344						
	GRT2{1}	2	118	361	380	-281	-9
-2	281						
	GRT3{1}	2	-9	453	453	-128	-9
-2	128						
F02	+ Gravity{1}	2	-107	87	138	-41	-9
-2	42						
	Hydrotest{1}	2	-104	87	135	-44	-9
-2	45						
	Thermal 1{1}	0	288	-99	304	-303	0
0	303						
	Thermal 2{1}	0	225	-100	246	-240	0
0	240						
	Thermal 3{1}	0	98	-9	98	-87	0
0	87						
	GRT1{1}	2	180	-12	181	-344	-9
-2	344						
	GRT2{1}	2	118	-13	119	-281	-9
-2	281						
	GRT3{1}	2	-9	78	79	-128	-9
-2	128						
F13	- Gravity{1}	2	-107	48	118	-60	-9
-1	60						
	Hydrotest{1}	2	-104	48	114	-63	-9
-1	63						
	Thermal 1{1}	0	288	-99	304	-276	0
0	276						
	Thermal 2{1}	0	225	-100	246	-212	0
0	212						
	Thermal 3{1}	0	98	-9	98	-84	0
0	84						
	GRT1{1}	2	180	-51	187	-335	-9
-1	336						

circuitoprovabarre.txt

-1	GRT2{1}	2	118	-52	129	-272	-9
-1	GRT3{1}	2	-9	39	40	-144	-9
F13 +	Gravity{1}	2	-74	30	80	-53	-10
-1	Hydrotest{1}	2	-71	30	77	-56	-10
0	Thermal 1{1}	0	289	-85	301	-258	0
0	Thermal 2{1}	0	222	-94	241	-205	0
0	Thermal 3{1}	0	96	-9	96	-84	0
-1	GRT1{1}	2	215	-55	222	-312	-10
-1	GRT2{1}	2	148	-64	161	-259	-10
-1	GRT3{1}	2	22	21	30	-138	-10

□

CIRCUITOPROVABARRE

07/30/2010 CIRCUITO PROVA BARRE
BENTLEY

02:16 PM

AutoPIPE Plus 9.2.1 RESULT PAGE 48

G L O B A L F O R C E S & M O M E N T S

Point) name Z	Load combination Result	FORCES (N)				MOMENTS (N.m)	
		X	Y	Z	Result	X	Y
F03	Gravity{1}	2	-74	-142	160	14	-10
2	Hydrotest{1}	2	-71	-142	159	12	-10
0	Thermal 1{1}	0	289	-85	301	-155	0
0	Thermal 2{1}	0	222	-94	241	-91	0
0	Thermal 3{1}	0	96	-9	96	-74	0
2	GRT1{1}	2	215	-226	312	-141	-10
2	GRT2{1}	2	148	-235	278	-77	-10
2	GRT3{1}	2	22	-151	152	-59	-10
F04	Gravity{1}	2	-74	-151	168	24	-10
2	Hydrotest{1}	2	-71	-151	167	22	-10
0	Thermal 1{1}	0	289	-85	301	-150	0
0	Thermal 2{1}	0	222	-94	241	-85	0

circuitoprovabarre.txt

0	85						
0	Thermal 3{1}	0	96	-9	96	-73	0
	73						
	GRT1{1}	2	215	-235	319	-126	-10
2	126						
	GRT2{1}	2	148	-244	286	-61	-10
2	62						
	GRT3{1}	2	22	-160	161	-49	-10
2	50						
F04	+ Gravity{1}	2	-74	-152	169	24	-10
2	26						
	Hydrotest{1}	2	-71	-152	168	22	-10
2	24						
	Thermal 1{1}	0	289	-85	301	-150	0
0	150						
	Thermal 2{1}	0	222	-94	241	-85	0
0	85						
	Thermal 3{1}	0	96	-9	96	-73	0
0	73						
	GRT1{1}	2	215	-237	320	-126	-10
2	126						
	GRT2{1}	2	148	-246	287	-61	-10
2	62						
	GRT3{1}	2	22	-161	162	-49	-10
2	50						
F05	Gravity{1}	2	-74	-161	177	34	-10
2	35						
	Hydrotest{1}	2	-71	-161	176	31	-10
2	33						
	Thermal 1{1}	0	289	-85	301	-144	0
0	144						
	Thermal 2{1}	0	222	-94	241	-79	0
0	79						
	Thermal 3{1}	0	96	-9	96	-72	0
0	72						
	GRT1{1}	2	215	-246	326	-111	-10
2	111						
	GRT2{1}	2	148	-255	295	-46	-10
2	47						
	GRT3{1}	2	22	-170	171	-39	-10
2	40						
F06	N Gravity{1}	2	-74	-161	177	34	-10
2	35						
	Hydrotest{1}	2	-71	-161	176	32	-10
2	33						
	Thermal 1{1}	0	289	-85	301	-144	0
0	144						
	Thermal 2{1}	0	222	-94	241	-79	0
0	79						
	Thermal 3{1}	0	96	-9	96	-72	0
0	72						
	GRT1{1}	2	215	-246	326	-110	-10
2	111						
	GRT2{1}	2	148	-255	295	-45	-10
2	46						
	GRT3{1}	2	22	-170	171	-39	-10
2	40						

□

 CIRCUITOPROVABARRE

07/30/2010 CIRCUITO PROVA BARRE
 BENTLEY

G L O B A L F O R C E S & M O M E N T S

Point) name Z	Load combination Result	FORCES (N)				MOMENTS (N.m)	
		X	Y	Z	Result	X	Y
F06 M 3	Gravity{1} 42	2	-74	-169	185	41	-10
3	Hydrotest{1} 40	2	-71	-170	184	39	-10
0	Thermal 1{1} 133	0	289	-85	301	-133	0
0	Thermal 2{1} 69	0	222	-94	241	-69	0
0	Thermal 3{1} 70	0	96	-9	96	-70	0
3	GRT1{1} 93	2	215	-254	333	-92	-10
3	GRT2{1} 30	2	148	-263	302	-28	-10
3	GRT3{1} 31	2	22	-178	180	-29	-10
F06 F 3	Gravity{1} 42	2	-74	-178	193	41	-10
3	Hydrotest{1} 40	2	-71	-178	192	39	-10
0	Thermal 1{1} 116	0	289	-85	301	-116	0
0	Thermal 2{1} 55	0	222	-94	241	-55	0
0	Thermal 3{1} 65	0	96	-9	96	-65	0
3	GRT1{1} 76	2	215	-262	339	-75	-10
3	GRT2{1} 18	2	148	-271	309	-14	-10
3	GRT3{1} 26	2	22	-187	188	-24	-10
F07 3	Gravity{1} 42	2	-74	-178	193	41	-10
3	Hydrotest{1} 40	2	-71	-178	192	39	-10
0	Thermal 1{1} 116	0	289	-85	301	-116	0
0	Thermal 2{1} 55	0	222	-94	241	-55	0
0	Thermal 3{1} 64	0	96	-9	96	-64	0
3	GRT1{1} 76	2	215	-263	339	-75	-10
3	GRT2{1} 18	2	148	-272	309	-14	-10
3	GRT3{1} 26	2	22	-187	188	-24	-10
F08 3	- Gravity{1} 32	2	-74	-197	210	31	-10

circuitoprovabarre.txt

3	Hydrotest{1}	2	-71	-197	210	29	-10
0	Thermal 1{1}	0	289	-85	301	-76	0
0	Thermal 2{1}	0	222	-94	241	-25	0
0	Thermal 3{1}	0	96	-9	96	-51	0
3	GRT1{1}	2	215	-282	354	-46	-10
3	GRT2{1}	2	148	-291	326	6	-10
3	GRT3{1}	2	22	-206	207	-21	-10
F08 +	Gravity{1}	2	-74	-384	391	31	-10
3	Hydrotest{1}	2	-71	-385	391	29	-10
0	Thermal 1{1}	0	289	-85	301	-76	0
0	Thermal 2{1}	0	222	-94	241	-25	0
0	Thermal 3{1}	0	96	-9	96	-51	0
3	GRT1{1}	2	215	-469	516	-46	-10
3	GRT2{1}	2	148	-478	500	6	-10
3	GRT3{1}	2	22	-393	394	-21	-10

□

CIRCUITOPROVABARRE

07/30/2010 CIRCUITO PROVA BARRE
BENTLEY

02:16 PM

AutoPIPE Plus 9.2.1 RESULT PAGE 50

G L O B A L F O R C E S & M O M E N T S

Point) name Z	Load combination Result	FORCES (N)				MOMENTS (N.m)	
		X	Y	Z	Result	X	Y
F08 M 3	Gravity{1}	2	-74	-731	734	14	-11
3	Hydrotest{1}	2	-71	-731	735	13	-11
0	Thermal 1{1}	0	289	-85	301	-11	0
0	Thermal 2{1}	0	222	-94	241	25	0
0	Thermal 3{1}	0	96	-9	96	-30	0
3	GRT1{1}	2	215	-815	843	3	-11
3	GRT2{1}	2	148	-824	838	39	-11

circuitoprovabarre.txt

3		GRT3{1}	2	22	-740	740	-16	-11
		19						
F09	-	Gravity{1}	2	-74	-1077	1080	-3	-11
3		12						
		Hydrotest{1}	2	-71	-1077	1080	-3	-11
3		12						
		Thermal 1{1}	0	289	-85	301	54	0
0		54						
		Thermal 2{1}	0	222	-94	241	75	0
0		75						
		Thermal 3{1}	0	96	-9	96	-8	0
0		8						
		GRT1{1}	2	215	-1162	1182	51	-11
3		52						
		GRT2{1}	2	148	-1171	1180	72	-11
3		73						
		GRT3{1}	2	22	-1086	1086	-11	-11
3		16						
F09	+	Gravity{1}	2	-74	-1264	1267	-3	-11
3		12						
		Hydrotest{1}	2	-71	-1265	1267	-3	-11
3		12						
		Thermal 1{1}	0	289	-85	301	54	0
0		54						
		Thermal 2{1}	0	222	-94	241	75	0
0		75						
		Thermal 3{1}	0	96	-9	96	-8	0
0		8						
		GRT1{1}	2	215	-1349	1366	51	-11
3		52						
		GRT2{1}	2	148	-1358	1366	72	-11
3		73						
		GRT3{1}	2	22	-1273	1273	-11	-11
3		16						
F16	-	Gravity{1}	2	-74	-1382	1384	-65	-13
3		66						
		Hydrotest{1}	2	-71	-1383	1385	-62	-13
3		64						
		Thermal 1{1}	0	289	-85	301	296	0
0		296						
		Thermal 2{1}	0	222	-94	241	261	0
0		261						
		Thermal 3{1}	0	96	-9	96	72	0
0		72						
		GRT1{1}	2	215	-1467	1483	231	-13
3		231						
		GRT2{1}	2	148	-1476	1484	196	-13
3		197						
		GRT3{1}	2	22	-1391	1392	7	-13
3		15						
F16	+	Gravity{1}	44	32	-1382	1384	-65	-13
3		66						
		Hydrotest{1}	44	31	-1383	1384	-62	-13
3		64						
		Thermal 1{1}	0	-69	-85	110	296	0
0		296						
		Thermal 2{1}	0	-65	-94	114	261	0
0		261						
		Thermal 3{1}	0	-18	-9	20	72	0
0		72						
		GRT1{1}	44	-37	-1467	1468	231	-13
3		231						
		GRT2{1}	44	-32	-1476	1477	196	-13
3		197						

3 GRT3{1} 44 14 -1391 1392 7 -13
15

□

CIRCUITOPROVABARRE

07/30/2010 CIRCUITO PROVA BARRE
BENTLEY

02:16 PM

AutoPIPE Plus 9.2.1 RESULT PAGE 51

G L O B A L F O R C E S & M O M E N T S

Point) name Z	Load combination Result	FORCES (N)				MOMENTS (N.m)	
		X	Y	Z	Result	X	Y
F10 3	- Gravity{1} 60	44	32	-1459	1460	-48	-37
3	Hydrotest{1} 59	44	31	-1459	1460	-45	-37
0	Thermal 1{1} 258	0	-69	-85	110	258	0
0	Thermal 2{1} 226	0	-65	-94	114	226	0
0	Thermal 3{1} 62	0	-18	-9	20	62	0
3	GRT1{1} 214	44	-37	-1544	1545	210	-37
3	GRT2{1} 183	44	-32	-1553	1554	179	-37
3	GRT3{1} 40	44	14	-1468	1468	15	-37
F10 3	+ Gravity{1} 60	44	32	-1833	1834	-48	-37
3	Hydrotest{1} 59	44	31	-1834	1835	-45	-37
0	Thermal 1{1} 258	0	-69	-85	110	258	0
0	Thermal 2{1} 226	0	-65	-94	114	226	0
0	Thermal 3{1} 62	0	-18	-9	20	62	0
3	GRT1{1} 214	44	-37	-1918	1919	210	-37
3	GRT2{1} 183	44	-32	-1927	1928	179	-37
3	GRT3{1} 40	44	14	-1842	1843	15	-37
F11 3	- Gravity{1} 96	44	32	-2020	2021	-5	-96
3	Hydrotest{1} 96	44	31	-2020	2021	-4	-96
0	Thermal 1{1} 166	0	-69	-85	110	166	0
0	Thermal 2{1} 141	0	-65	-94	114	141	0
0	Thermal 3{1}	0	-18	-9	20	38	0

circuitoprovabarre.txt

0	38							
	GRT1{1}	44	-37	-2105	2105	161	-96	
3	187							
	GRT2{1}	44	-32	-2114	2114	136	-96	
3	166							
	GRT3{1}	44	14	-2029	2029	33	-96	
3	101							
F11	+ Gravity{1}	44	32	-5209	5209	-5	178	
3	178							
	Hydrotest{1}	44	31	-5209	5210	-4	178	
3	178							
	Thermal 1{1}	0	-69	-85	110	166	0	
0	166							
	Thermal 2{1}	0	-65	-94	114	141	0	
0	141							
	Thermal 3{1}	0	-18	-9	20	38	0	
0	38							
	GRT1{1}	44	-37	-5294	5294	161	178	
3	240							
	GRT2{1}	44	-32	-5303	5303	136	178	
3	224							
	GRT3{1}	44	14	-5218	5218	33	178	
3	181							
A13	Gravity{1}	44	32	-5854	5854	141	-24	
3	143							
	Hydrotest{1}	44	31	-5854	5855	140	-24	
3	142							
	Thermal 1{1}	0	-69	-85	110	-151	0	
0	151							
	Thermal 2{1}	0	-65	-94	114	-154	0	
0	154							
	Thermal 3{1}	0	-18	-9	20	-45	0	
0	45							
	GRT1{1}	44	-37	-5939	5939	-10	-24	
3	26							
	GRT2{1}	44	-32	-5948	5948	-13	-24	
3	27							
	GRT3{1}	44	14	-5863	5863	96	-24	
3	99							

*** Segment F end ***

*** Segment G begin ***

□

 CIRCUITOPROVABARRE

07/30/2010 CIRCUITO PROVA BARRE
 BENTLEY

02:16 PM

AutoPIPE Plus 9.2.1 RESULT PAGE 52

 GLOBAL FORCES & MOMENTS

Point) name	Load combination Result	FORCES (N)			MOMENTS (N.m)	
		X	Y	Z	Result	X

circuitoprovabarre.txt

F04	Gravity{1}	0	0	1	1	0	0
0	0						
	Hydrotest{1}	0	0	1	1	0	0
0	0						
	Thermal 1{1}	0	0	0	0	0	0
0	0						
	Thermal 2{1}	0	0	0	0	0	0
0	0						
	Thermal 3{1}	0	0	0	0	0	0
0	0						
	GRT1{1}	0	0	1	1	0	0
0	0						
	GRT2{1}	0	0	1	1	0	0
0	0						
	GRT3{1}	0	0	1	1	0	0
0	0						

G01	Gravity{1}	0	0	0	0	0	0
0	0						
	Hydrotest{1}	0	0	0	0	0	0
0	0						
	Thermal 1{1}	0	0	0	0	0	0
0	0						
	Thermal 2{1}	0	0	0	0	0	0
0	0						
	Thermal 3{1}	0	0	0	0	0	0
0	0						
	GRT1{1}	0	0	0	0	0	0
0	0						
	GRT2{1}	0	0	0	0	0	0
0	0						
	GRT3{1}	0	0	0	0	0	0
0	0						

*** Segment G end ***

*** Segment H begin ***

F13	Gravity{1}	0	-33	18	38	-6	0
0	6						
	Hydrotest{1}	0	-33	18	38	-6	0
0	6						
	Thermal 1{1}	0	-1	-14	14	-18	0
0	18						
	Thermal 2{1}	0	3	-7	7	-7	0
0	7						
	Thermal 3{1}	0	2	0	2	0	0
0	0						
	GRT1{1}	0	-34	4	35	-24	0
0	24						
	GRT2{1}	0	-30	12	32	-13	0
0	13						
	GRT3{1}	0	-31	18	36	-6	0
0	6						

H01 N	Gravity{1}	0	-33	14	36	5	0
0	5						
	Hydrotest{1}	0	-33	14	36	5	0
0	5						
	Thermal 1{1}	0	-1	-14	14	-17	0
0	17						
	Thermal 2{1}	0	3	-7	7	-8	0
0	8						
	Thermal 3{1}	0	2	0	2	0	0
0	0						
	GRT1{1}	0	-34	0	34	-12	0
0	12						
	GRT2{1}	0	-30	8	31	-3	0

circuitoprovabarre.txt

0	3						
0	GRT3{1}	0	-31	14	34	4	0
	4						
H01 M	Gravity{1}	0	-33	14	36	5	0
0	5						
0	Hydrotest{1}	0	-33	14	36	5	0
0	5						
0	Thermal 1{1}	0	-1	-14	14	-17	0
0	17						
0	Thermal 2{1}	0	3	-7	7	-8	0
0	8						
0	Thermal 3{1}	0	2	0	2	0	0
0	0						
0	GRT1{1}	0	-34	0	34	-12	0
0	12						
0	GRT2{1}	0	-30	8	31	-3	0
0	3						
0	GRT3{1}	0	-31	14	34	5	0
0	5						

□

CIRCUITOPROVABARRE

07/30/2010 CIRCUITO PROVA BARRE
BENTLEY

02:16 PM

AutoPIPE Plus 9.2.1 RESULT PAGE 53

G L O B A L F O R C E S & M O M E N T S

Point) name Z	Load combination Result	FORCES (N)				MOMENTS (N.m)	
		X	Y	Z	Result	X	Y
H01 F	Gravity{1}	0	-33	14	36	5	0
0	5						
0	Hydrotest{1}	0	-33	14	36	5	0
0	5						
0	Thermal 1{1}	0	-1	-14	14	-17	0
0	17						
0	Thermal 2{1}	0	3	-7	7	-8	0
0	8						
0	Thermal 3{1}	0	2	0	2	0	0
0	0						
0	GRT1{1}	0	-34	0	34	-12	0
0	12						
0	GRT2{1}	0	-30	7	31	-3	0
0	3						
0	GRT3{1}	0	-31	14	34	5	0
0	5						
H02	Gravity{1}	0	-33	-10	34	1	0
0	1						
0	Hydrotest{1}	0	-33	-10	34	1	0
0	1						
0	Thermal 1{1}	0	-1	-14	14	12	0
0	12						
0	Thermal 2{1}	0	3	-7	7	5	0
0	5						

circuitoprovabarre.txt

0	0	Thermal 3{1}	1	0	2	0	2	-1	0
0	0	GRT1{1}	13	0	-34	-24	42	13	0
0	0	GRT2{1}	6	0	-30	-16	34	6	0
0	0	GRT3{1}	0	0	-31	-10	32	0	0
H03	-	Gravity{1}	1	0	-33	-10	34	1	0
0	0	Hydrotest{1}	1	0	-33	-10	34	1	0
0	0	Thermal 1{1}	12	0	-1	-14	14	12	0
0	0	Thermal 2{1}	5	0	3	-7	7	5	0
0	0	Thermal 3{1}	1	0	2	0	2	-1	0
0	0	GRT1{1}	13	0	-34	-24	42	13	0
0	0	GRT2{1}	6	0	-30	-16	34	6	0
0	0	GRT3{1}	0	0	-31	-10	32	0	0
H03	+	Gravity{1}	1	0	-33	-13	35	1	0
0	0	Hydrotest{1}	1	0	-33	-13	35	1	0
0	0	Thermal 1{1}	12	0	-1	-14	14	12	0
0	0	Thermal 2{1}	5	0	3	-7	7	5	0
0	0	Thermal 3{1}	1	0	2	0	2	-1	0
0	0	GRT1{1}	13	0	-34	-27	44	13	0
0	0	GRT2{1}	6	0	-30	-19	36	6	0
0	0	GRT3{1}	0	0	-31	-13	33	0	0
H04		Gravity{1}	1	0	-33	-13	35	1	0
0	0	Hydrotest{1}	1	0	-33	-13	35	1	0
0	0	Thermal 1{1}	12	0	-1	-14	14	12	0
0	0	Thermal 2{1}	5	0	3	-7	7	5	0
0	0	Thermal 3{1}	1	0	2	0	2	-1	0
0	0	GRT1{1}	14	0	-34	-27	44	14	0
0	0	GRT2{1}	7	0	-30	-19	36	7	0
0	0	GRT3{1}	1	0	-31	-13	33	1	0

□

CIRCUITOPROVABARRE

07/30/2010 CIRCUITO PROVA BARRE
BENTLEY

02:16 PM

G L O B A L F O R C E S & M O M E N T S

Point) name Z	Load combination Result	FORCES (N)				MOMENTS (N.m)	
		X	Y	Z	Result	X	Y
H12	Gravity{1}	0	-33	-14	36	2	0
0	2						
	Hydrotest{1}	0	-33	-14	36	2	0
0	2						
	Thermal 1{1}	0	-1	-14	14	14	0
0	14						
	Thermal 2{1}	0	3	-7	7	6	0
0	6						
	Thermal 3{1}	0	2	0	2	-1	0
0	1						
	GRT1{1}	0	-34	-28	44	16	0
0	16						
	GRT2{1}	0	-30	-20	36	8	0
0	8						
	GRT3{1}	0	-31	-14	34	2	0
0	2						
H05 N	Gravity{1}	0	-33	-14	36	3	0
0	3						
	Hydrotest{1}	0	-33	-15	36	3	0
0	3						
	Thermal 1{1}	0	-1	-14	14	14	0
0	14						
	Thermal 2{1}	0	3	-7	7	6	0
0	6						
	Thermal 3{1}	0	2	0	2	-1	0
0	1						
	GRT1{1}	0	-34	-29	45	18	0
0	18						
	GRT2{1}	0	-30	-21	37	9	0
0	9						
	GRT3{1}	0	-31	-14	34	3	0
0	3						
H05 M	Gravity{1}	0	-33	-15	36	3	0
0	3						
	Hydrotest{1}	0	-33	-15	36	3	0
0	3						
	Thermal 1{1}	0	-1	-14	14	15	0
0	15						
	Thermal 2{1}	0	3	-7	7	6	0
0	6						
	Thermal 3{1}	0	2	0	2	-1	0
0	1						
	GRT1{1}	0	-34	-29	45	18	0
0	18						
	GRT2{1}	0	-30	-21	37	10	0
0	10						
	GRT3{1}	0	-31	-15	34	3	0
0	3						
H05 F	Gravity{1}	0	-33	-15	36	3	0
0	3						
	Hydrotest{1}	0	-33	-15	36	3	0

circuitoprovabarre.txt

0	3	Thermal 1{1}	0	-1	-14	14	15	0
0	15	Thermal 2{1}	0	3	-7	7	6	0
0	6	Thermal 3{1}	0	2	0	2	-1	0
0	1	GRT1{1}	0	-34	-29	45	17	0
0	17	GRT2{1}	0	-30	-21	37	9	0
0	9	GRT3{1}	0	-31	-15	34	2	0
0	2							
H06		Gravity{1}	0	-33	-22	40	-17	0
0	17	Hydrotest{1}	0	-33	-22	40	-17	0
0	17	Thermal 1{1}	0	-1	-14	14	14	0
0	14	Thermal 2{1}	0	3	-7	7	8	0
0	8	Thermal 3{1}	0	2	0	2	1	0
0	1	GRT1{1}	0	-34	-36	50	-4	0
0	4	GRT2{1}	0	-30	-28	42	-9	0
0	9	GRT3{1}	0	-31	-22	38	-17	0
0	17							

□

CIRCUITOPROVABARRE

07/30/2010 CIRCUITO PROVA BARRE
BENTLEY

02:16 PM

AutoPIPE Plus 9.2.1 RESULT PAGE 55

GLOBAL FORCES & MOMENTS

Point) name Z	Load combination Result	FORCES (N)				MOMENTS (N.m)	
		X	Y	Z	Result	X	Y
H07	Gravity{1}	0	-33	-23	40	-19	0
0	19						
0	Hydrotest{1}	0	-33	-23	40	-19	0
0	19						
0	Thermal 1{1}	0	-1	-14	14	14	0
0	14						
0	Thermal 2{1}	0	3	-7	7	8	0
0	8						
0	Thermal 3{1}	0	2	0	2	1	0
0	1						
0	GRT1{1}	0	-34	-38	51	-5	0
0	5						
0	GRT2{1}	0	-30	-30	42	-11	0
0	11						
0	GRT3{1}	0	-31	-23	39	-18	0

circuitprovabarre.txt

0	18							
H08	-	Gravity{1}	0	-33	-26	42	-22	0
0		22						
		Hydrotest{1}	0	-33	-26	42	-21	0
0		21						
		Thermal 1{1}	0	-1	-14	14	14	0
0		14						
		Thermal 2{1}	0	3	-7	7	8	0
0		8						
		Thermal 3{1}	0	2	0	2	1	0
0		1						
		GRT1{1}	0	-34	-40	53	-8	0
0		8						
		GRT2{1}	0	-30	-32	44	-13	0
0		13						
		GRT3{1}	0	-31	-26	40	-21	0
0		21						
H08	+	Gravity{1}	0	-33	-66	74	-22	0
0		22						
		Hydrotest{1}	0	-33	-66	74	-21	0
0		21						
		Thermal 1{1}	0	-1	-14	14	14	0
0		14						
		Thermal 2{1}	0	3	-7	7	8	0
0		8						
		Thermal 3{1}	0	2	0	2	1	0
0		1						
		GRT1{1}	0	-34	-81	88	-8	0
0		8						
		GRT2{1}	0	-30	-73	79	-13	0
0		13						
		GRT3{1}	0	-31	-66	73	-21	0
0		21						
H08	M-	Gravity{1}	0	-33	-214	216	-26	0
0		26						
		Hydrotest{1}	0	-33	-214	216	-26	0
0		26						
		Thermal 1{1}	0	-1	-14	14	13	0
0		13						
		Thermal 2{1}	0	3	-7	7	9	0
0		9						
		Thermal 3{1}	0	2	0	2	1	0
0		1						
		GRT1{1}	0	-34	-228	231	-12	0
0		12						
		GRT2{1}	0	-30	-220	222	-17	0
0		17						
		GRT3{1}	0	-31	-214	216	-24	0
0		24						
H08	M+	Gravity{1}	0	-33	436	437	92	0
0		92						
		Hydrotest{1}	0	-33	5454	5454	92	0
0		92						
		Thermal 1{1}	0	-1	-14	14	13	0
0		13						
		Thermal 2{1}	0	3	209	209	9	0
0		9						
		Thermal 3{1}	0	2	130	130	1	0
0		1						
		GRT1{1}	0	-34	421	423	105	0
0		105						
		GRT2{1}	0	-30	644	645	101	0
0		101						
		GRT3{1}	0	-31	566	567	93	0
0								

□

CIRCUITOPROVABARRE

07/30/2010 CIRCUITO PROVA BARRE
BENTLEY

02:16 PM

AutoPIPE Plus 9.2.1 RESULT PAGE 56

G L O B A L F O R C E S & M O M E N T S

Point) name Z	Load combination Result	FORCES (N)				MOMENTS (N.m)	
		X	Y	Z	Result	X	Y
H09 0	- Gravity{1} 88	0	-33	288	290	88	0
0	Hydrotest{1} 88	0	-33	5306	5306	88	0
0	Thermal 1{1} 13	0	-1	-14	14	13	0
0	Thermal 2{1} 9	0	3	209	209	9	0
0	Thermal 3{1} 2	0	2	130	130	2	0
0	GRT1{1} 101	0	-34	274	276	101	0
0	GRT2{1} 97	0	-30	497	498	97	0
0	GRT3{1} 89	0	-31	418	419	89	0
H09 0	+ Gravity{1} 88	0	-33	248	250	88	0
0	Hydrotest{1} 88	0	-33	5266	5266	88	0
0	Thermal 1{1} 13	0	-1	-14	14	13	0
0	Thermal 2{1} 9	0	3	209	209	9	0
0	Thermal 3{1} 2	0	2	130	130	2	0
0	GRT1{1} 101	0	-34	233	236	101	0
0	GRT2{1} 97	0	-30	456	457	97	0
0	GRT3{1} 89	0	-31	378	379	89	0
H17 0	- Gravity{1} 27	0	-33	120	125	-27	0
0	Hydrotest{1} 27	0	-33	5139	5139	-27	0
0	Thermal 1{1} 9	0	-1	-14	14	9	0
0	Thermal 2{1} 19	0	3	209	209	19	0
0	Thermal 3{1} 9	0	2	130	130	9	0

circuitoprovabarre.txt

0	GRT1{1}	0	-34	106	111	-19	0
0	19						
0	GRT2{1}	0	-30	329	330	-9	0
0	9						
0	GRT3{1}	0	-31	250	252	-18	0
0	18						
H17	+ Gravity{1}	-1	8	120	120	-27	0
0	27						
0	Hydrotest{1}	-1	7	5139	5139	-27	0
0	27						
0	Thermal 1{1}	0	-9	-14	17	9	0
0	9						
0	Thermal 2{1}	0	-17	209	209	19	0
0	19						
0	Thermal 3{1}	0	-6	130	130	9	0
0	9						
0	GRT1{1}	-1	-1	106	106	-19	0
0	19						
0	GRT2{1}	-1	-9	329	329	-9	0
0	9						
0	GRT3{1}	-1	1	250	250	-18	0
0	18						
H10	- Gravity{1}	-1	8	107	108	-25	0
0	25						
0	Hydrotest{1}	-1	7	5126	5126	-24	0
0	24						
0	Thermal 1{1}	0	-9	-14	17	5	0
0	5						
0	Thermal 2{1}	0	-17	209	209	13	0
0	13						
0	Thermal 3{1}	0	-6	130	130	7	0
0	7						
0	GRT1{1}	-1	-1	93	93	-19	0
0	19						
0	GRT2{1}	-1	-9	316	316	-12	0
0	12						
0	GRT3{1}	-1	1	237	238	-18	0
0	18						

□

CIRCUITOPROVABARRE

07/30/2010 CIRCUITO PROVA BARRE
BENTLEY

02:16 PM

AutoPIPE Plus 9.2.1 RESULT PAGE 57

G L O B A L F O R C E S & M O M E N T S

Point) name Z	Load combination Result	FORCES (N)				MOMENTS (N.m)	
		X	Y	Z	Result	X	Y
H10	+ Gravity{1}	-1	8	-597	597	-25	0
0	25						
0	Hydrotest{1}	-1	7	4422	4422	-24	0
0	24						
0	Thermal 1{1}	0	-9	-14	17	5	0

circuitoprovabarre.txt

0	5						
0	Thermal 2{1}	0	-17	209	209	13	0
0	13						
0	Thermal 3{1}	0	-6	130	130	7	0
0	7						
0	GRT1{1}	-1	-1	-611	611	-19	0
0	19						
0	GRT2{1}	-1	-9	-388	388	-12	0
0	12						
0	GRT3{1}	-1	1	-467	467	-18	0
0	18						
H20	- Gravity{1}	-1	8	-721	721	1	5
0	5						
0	Hydrotest{1}	-1	7	4297	4297	0	5
0	5						
0	Thermal 1{1}	0	-9	-14	17	-25	0
0	25						
0	Thermal 2{1}	0	-17	209	209	-44	0
0	44						
0	Thermal 3{1}	0	-6	130	130	-15	0
0	15						
0	GRT1{1}	-1	-1	-735	735	-24	5
0	24						
0	GRT2{1}	-1	-9	-512	512	-43	5
0	43						
0	GRT3{1}	-1	1	-591	591	-14	5
0	15						
H20	+ Gravity{1}	-1	8	254	254	1	5
0	5						
0	Hydrotest{1}	-1	7	257	257	0	5
0	5						
0	Thermal 1{1}	0	-9	133	133	-25	0
0	25						
0	Thermal 2{1}	0	-17	221	222	-44	0
0	44						
0	Thermal 3{1}	0	-6	71	71	-15	0
0	15						
0	GRT1{1}	-1	-1	387	387	-24	5
0	24						
0	GRT2{1}	-1	-9	476	476	-43	5
0	43						
0	GRT3{1}	-1	1	325	325	-14	5
0	15						
D07	Gravity{1}	-1	8	250	250	2	5
0	6						
0	Hydrotest{1}	-1	7	253	253	1	5
0	6						
0	Thermal 1{1}	0	-9	133	133	-26	0
0	26						
0	Thermal 2{1}	0	-17	221	222	-46	0
0	46						
0	Thermal 3{1}	0	-6	71	71	-15	0
0	15						
0	GRT1{1}	-1	-1	383	383	-24	5
0	25						
0	GRT2{1}	-1	-9	472	472	-44	5
0	44						
0	GRT3{1}	-1	1	321	321	-14	5
0	15						

*** Segment H end ***

*** Segment I begin ***

H03	Gravity{1}	0	0	3	3	0	0
-----	------------	---	---	---	---	---	---

circuitoprovabarre.txt

0	0						
0	Hydrotest{1}	0	0	3	3	0	0
0	0						
0	Thermal 1{1}	0	0	0	0	0	0
0	0						
0	Thermal 2{1}	0	0	0	0	0	0
0	0						
0	Thermal 3{1}	0	0	0	0	0	0
0	0						
0	GRT1{1}	0	0	3	3	0	0
0	0						
0	GRT2{1}	0	0	3	3	0	0
0	0						
0	GRT3{1}	0	0	3	3	0	0
0	0						

□

CIRCUITOPROVABARRE

07/30/2010 CIRCUITO PROVA BARRE
BENTLEY

02:16 PM

AutoPIPE Plus 9.2.1

RESULT PAGE 58

GLOBAL FORCES & MOMENTS

Point) name Z	Load combination Result	FORCES (N)				MOMENTS (N.m)	
		X	Y	Z	Result	X	Y
I02	Gravity{1}	0	0	1	1	0	0
0	0						
0	Hydrotest{1}	0	0	1	1	0	0
0	0						
0	Thermal 1{1}	0	0	0	0	0	0
0	0						
0	Thermal 2{1}	0	0	0	0	0	0
0	0						
0	Thermal 3{1}	0	0	0	0	0	0
0	0						
0	GRT1{1}	0	0	1	1	0	0
0	0						
0	GRT2{1}	0	0	1	1	0	0
0	0						
0	GRT3{1}	0	0	1	1	0	0
0	0						
I01	Gravity{1}	0	0	0	0	0	0
0	0						
0	Hydrotest{1}	0	0	0	0	0	0
0	0						
0	Thermal 1{1}	0	0	0	0	0	0
0	0						
0	Thermal 2{1}	0	0	0	0	0	0
0	0						
0	Thermal 3{1}	0	0	0	0	0	0
0	0						
0	GRT1{1}	0	0	0	0	0	0
0	0						
0	GRT2{1}	0	0	0	0	0	0

circuitoprovabarre.txt

0	0						
0	GRT3{1}	0	0	0	0	0	0
0	0						
*** Segment I end ***							
*** Segment J begin ***							
B05	Gravity{1}	0	0	144	144	68	0
0	68						
0	Hydrotest{1}	0	0	144	144	68	0
0	68						
0	Thermal 1{1}	0	0	0	0	0	0
0	0						
0	Thermal 2{1}	0	0	0	0	0	0
0	0						
0	Thermal 3{1}	0	0	0	0	0	0
0	0						
0	GRT1{1}	0	0	144	144	68	0
0	68						
0	GRT2{1}	0	0	144	144	68	0
0	68						
0	GRT3{1}	0	0	144	144	68	0
0	68						
J01	Gravity{1}	0	0	127	127	5	0
0	5						
0	Hydrotest{1}	0	0	127	127	5	0
0	5						
0	Thermal 1{1}	0	0	0	0	0	0
0	0						
0	Thermal 2{1}	0	0	0	0	0	0
0	0						
0	Thermal 3{1}	0	0	0	0	0	0
0	0						
0	GRT1{1}	0	0	127	127	5	0
0	5						
0	GRT2{1}	0	0	127	127	5	0
0	5						
0	GRT3{1}	0	0	127	127	5	0
0	5						
J02 N	Gravity{1}	0	0	127	127	5	0
0	5						
0	Hydrotest{1}	0	0	127	127	5	0
0	5						
0	Thermal 1{1}	0	0	0	0	0	0
0	0						
0	Thermal 2{1}	0	0	0	0	0	0
0	0						
0	Thermal 3{1}	0	0	0	0	0	0
0	0						
0	GRT1{1}	0	0	127	127	5	0
0	5						
0	GRT2{1}	0	0	127	127	5	0
0	5						
0	GRT3{1}	0	0	127	127	5	0
0	5						

□

 CIRCUITOPROVABARRE

07/30/2010 CIRCUITO PROVA BARRE
 BENTLEY

02:16 PM

AutoPIPE Plus 9.2.1

RESULT PAGE 59
 Pagina 121

GLOBAL FORCES & MOMENTS

Point) name Z	Load combination Result	FORCES (N)				MOMENTS (N.m)	
		X	Y	Z	Result	X	Y
J02	Gravity{1}	0	0	125	125	0	0
0	Hydrotest{1}	0	0	125	125	0	0
0	Thermal 1{1}	0	0	0	0	0	0
0	Thermal 2{1}	0	0	0	0	0	0
0	Thermal 3{1}	0	0	0	0	0	0
0	GRT1{1}	0	0	125	125	0	0
0	GRT2{1}	0	0	125	125	0	0
0	GRT3{1}	0	0	125	125	0	0
J03	Gravity{1}	0	0	125	125	0	0
0	Hydrotest{1}	0	0	125	125	0	0
0	Thermal 1{1}	0	0	0	0	0	0
0	Thermal 2{1}	0	0	0	0	0	0
0	Thermal 3{1}	0	0	0	0	0	0
0	GRT1{1}	0	0	125	125	0	0
0	GRT2{1}	0	0	125	125	0	0
0	GRT3{1}	0	0	125	125	0	0
J04	Gravity{1}	0	0	116	116	0	0
0	Hydrotest{1}	0	0	116	116	0	0
0	Thermal 1{1}	0	0	0	0	0	0
0	Thermal 2{1}	0	0	0	0	0	0
0	Thermal 3{1}	0	0	0	0	0	0
0	GRT1{1}	0	0	116	116	0	0
0	GRT2{1}	0	0	116	116	0	0
0	GRT3{1}	0	0	116	116	0	0

*** Segment J end ***

*** Segment K begin ***

circuitoprovabarre.txt

D03	Gravity{1}	0	0	3	3	0	0
0	0						
	Hydrotest{1}	0	0	3	3	0	0
0	0						
	Thermal 1{1}	0	0	0	0	0	0
0	0						
	Thermal 2{1}	0	0	0	0	0	0
0	0						
	Thermal 3{1}	0	0	0	0	0	0
0	0						
	GRT1{1}	0	0	3	3	0	0
0	0						
	GRT2{1}	0	0	3	3	0	0
0	0						
	GRT3{1}	0	0	3	3	0	0
0	0						
K01	Gravity{1}	0	0	0	0	0	0
0	0						
	Hydrotest{1}	0	0	0	0	0	0
0	0						
	Thermal 1{1}	0	0	0	0	0	0
0	0						
	Thermal 2{1}	0	0	0	0	0	0
0	0						
	Thermal 3{1}	0	0	0	0	0	0
0	0						
	GRT1{1}	0	0	0	0	0	0
0	0						
	GRT2{1}	0	0	0	0	0	0
0	0						
	GRT3{1}	0	0	0	0	0	0
0	0						

*** Segment K end ***

□

 CIRCUITOPROVABARRE

07/30/2010 CIRCUITO PROVA BARRE
 BENTLEY

02:16 PM

AutoPIPE Plus 9.2.1 RESULT PAGE 60

 G E N E R A L P I P E S T R E S S R E P O R T

(Stress in N/mm2)

Point Total name Stress	Load combination Loc	Hoop	Longitudinal		Shear	Principal	
		Stress	Max	Min	Stress	Max	Min
-----	-----	-----	-----	-----	-----	-----	-----
-----	---	-----	-----	-----	-----	-----	-----

*** Segment A begin ***

A20	SIFI= 1.00	SIFO= 1.00					
	Gravity{1}		0	1	1	0	1
1	270						
	Hydrotest{1}		65	21	21	0	65
57	270						
	Thermal 1{1}		0	0	0	0	0
0	270						
	Thermal 2{1}		0	0	0	0	0

circuitoprovabarre.txt

0	270						
	Thermal 3{1}	0	0	0	0	0	0
0	90						
	GRT1{1}	0	1	1	0	1	0
1	270						
	GRT2{1}	0	1	1	0	1	0
1	270						
	GRT3{1}	0	1	1	0	1	0
1	270						
A19	- SIFI= 1.00 SIFO= 1.00						
	Gravity{1}	0	1	1	0	1	0
1	270						
	Hydrotest{1}	65	21	21	0	65	21
57	270						
	Thermal 1{1}	0	0	0	0	0	0
0	270						
	Thermal 2{1}	0	0	0	0	0	0
0	270						
	Thermal 3{1}	0	0	0	0	0	0
0	90						
	GRT1{1}	0	1	1	0	1	0
1	270						
	GRT2{1}	0	1	1	0	1	0
1	270						
	GRT3{1}	0	1	1	0	1	0
1	270						
A19	+ SIFI= 1.00 SIFO= 1.00						
	Gravity{1}	0	1	1	0	1	0
1	270						
	Hydrotest{1}	76	27	27	0	76	27
67	270						
	Thermal 1{1}	0	0	0	0	0	0
0	90						
	Thermal 2{1}	0	0	0	0	0	0
0	90						
	Thermal 3{1}	0	0	0	0	0	0
0	90						
	GRT1{1}	0	1	1	0	1	0
1	270						
	GRT2{1}	0	1	1	0	1	0
1	270						
	GRT3{1}	0	1	1	0	1	0
1	270						
A18	SIFI= 1.00 SIFO= 1.00						
	Gravity{1}	0	1	1	0	1	0
1	270						
	Hydrotest{1}	76	27	27	0	76	27
67	270						
	Thermal 1{1}	0	0	0	0	0	0
0	90						
	Thermal 2{1}	0	0	0	0	0	0
0	90						
	Thermal 3{1}	0	0	0	0	0	0
0	90						
	GRT1{1}	0	1	1	0	1	0
1	270						
	GRT2{1}	0	1	1	0	1	0
1	270						
	GRT3{1}	0	1	1	0	1	0
1	270						
A17	SIFI= 1.00 SIFO= 1.00						
	Gravity{1}	0	1	1	0	1	0
1	270						
	Hydrotest{1}	76	28	28	0	76	28

circuitoprovabarre.txt

67	270	Thermal 1{1}	0	0	0	0	0	0
0	270	Thermal 2{1}	0	0	0	0	0	0
0	270	Thermal 3{1}	0	0	0	0	0	0
0	270	GRT1{1}	0	1	1	0	1	0
1	270	GRT2{1}	0	1	1	0	1	0
1	270	GRT3{1}	0	1	1	0	1	0
1	270							

□

CIRCUITOPROVABARRE

07/30/2010 CIRCUITO PROVA BARRE
BENTLEY

02:16 PM

AutoPIPE Plus 9.2.1 RESULT PAGE 61

GENERAL PIPE STRESS REPORT

(Stress in N/mm2)

Point Total name Stress	Load combination Loc	Hoop Stress	Longitudinal		Shear Stress	Principal	
			Max	Min		Max	Min
A15 -	SIFI= 2.10 SIFO= 2.10						
1	Gravity{1}	0	1	1	0	1	0
67	Hydrotest{1}	76	28	28	0	76	28
0	270 Thermal 1{1}	0	0	0	0	0	0
0	270 Thermal 2{1}	0	0	0	0	0	0
0	270 Thermal 3{1}	0	0	0	0	0	0
1	270 GRT1{1}	0	1	1	0	1	0
1	270 GRT2{1}	0	1	1	0	1	0
1	270 GRT3{1}	0	1	1	0	1	0
A15 +	SIFI= 2.10 SIFO= 2.10						
16	5 Gravity{1}	0	16	-12	0	16	-12
70	Hydrotest{1}	76	42	15	0	76	15
44	185 Thermal 1{1}	0	44	-44	0	44	-44
35	0 Thermal 2{1}	0	35	-35	0	35	-35
12	0 Thermal 3{1}	0	12	-12	0	12	-12
31	0 GRT1{1}	0	31	-28	0	31	-28
	178 GRT2{1}	0	23	-20	0	23	-20

circuitoprovabarre.txt

23	177							
4	GRT3{1}		0	4	-1	0	4	-1
	30							
A16	SIFI= 1.00	SIFO= 1.00						
8	Gravity{1}		0	8	-5	0	8	-5
	84							
68	Hydrotest{1}		76	34	22	0	76	22
	264							
20	Thermal 1{1}		0	20	-20	0	20	-20
	90							
16	Thermal 2{1}		0	16	-16	0	16	-16
	90							
5	Thermal 3{1}		0	5	-5	0	5	-5
	90							
15	GRT1{1}		0	15	-12	0	15	-12
	273							
11	GRT2{1}		0	11	-8	0	11	-8
	274							
3	GRT3{1}		0	3	1	0	3	0
	59							
A22	SIFI= 1.00	SIFO= 1.00						
6	Gravity{1}		0	6	-2	0	6	-2
	282							
68	Hydrotest{1}		76	32	24	0	76	24
	103							
7	Thermal 1{1}		0	7	-7	0	7	-7
	270							
5	Thermal 2{1}		0	5	-5	0	5	-5
	270							
4	Thermal 3{1}		0	4	-4	0	4	-4
	270							
5	GRT1{1}		0	5	-2	0	5	-2
	76							
3	GRT2{1}		0	3	0	0	3	0
	56							
3	GRT3{1}		0	3	1	0	3	0
	9							
A14	SIFI= 1.00	SIFO= 1.00						
5	Gravity{1}		0	5	-1	0	5	-1
	72							
67	Hydrotest{1}		76	32	25	0	76	25
	252							
1	Thermal 1{1}		0	1	-1	0	1	-1
	270							
0	Thermal 2{1}		0	0	0	0	0	0
	270							
1	Thermal 3{1}		0	1	-1	0	1	-1
	270							
6	GRT1{1}		0	6	-2	0	6	-2
	75							
5	GRT2{1}		0	5	-1	0	5	-1
	72							
6	GRT3{1}		0	6	-2	0	6	-2
	75							
A04	SIFI= 1.00	SIFO= 1.00						
10	Gravity{1}		0	10	-5	0	10	-5
	81							

□

 CIRCUITOPROVABARRE

07/30/2010 CIRCUITO PROVA BARRE
 BENTLEY

GENERAL PIPE STRESS REPORT

(Stress in N/mm2)

Point Total name Stress	Load combination Loc	Hoop Stress	Longitudinal Max Min	Shear Stress	Principal Max Min
68	Hydrotest{1} 261	76	36 22	0	76 22
3	Thermal 1{1} 90	0	3 -3	0	3 -3
3	Thermal 2{1} 90	0	3 -3	0	3 -3
2	Thermal 3{1} 90	0	2 -2	0	2 -2
7	GRT1{1} 75	0	7 -2	0	7 -2
7	GRT2{1} 75	0	7 -2	0	7 -2
9	GRT3{1} 79	0	9 -3	0	9 -3
A03 N-	SIFI= 1.00 SIFO= 1.00 Gravity{1}	0	11 -5	0	11 -5
11	82				
68	Hydrotest{1} 262	76	37 22	0	76 22
4	Thermal 1{1} 90	0	3 -4	0	3 -4
3	Thermal 2{1} 90	0	3 -3	0	3 -3
2	Thermal 3{1} 90	0	2 -2	0	2 -2
7	GRT1{1} 75	0	7 -1	0	7 -1
7	GRT2{1} 76	0	7 -2	0	7 -2
9	GRT3{1} 79	0	9 -3	0	9 -3
A03 N+	SIFI= 1.00 SIFO= 1.00 Gravity{1}	0	11 -5	0	11 -5
11	352				
68	Hydrotest{1} 172	76	37 22	0	76 22
4	Thermal 1{1} 0	0	3 -4	0	3 -4
3	Thermal 2{1} 0	0	3 -3	0	3 -3
2	Thermal 3{1} 0	0	2 -2	0	2 -2
7	GRT1{1} 345	0	7 -1	0	7 -1
7	GRT2{1} 346	0	7 -2	0	7 -2
9	GRT3{1} 349	0	9 -3	0	9 -3
A03 M	SIFI= 1.00 SIFO= 1.00 Gravity{1}	0	4 0	0	4 0

circuitoprovabarre.txt

4	339						
	Hydrotest{1}	76	30	27	0	76	27
67	158						
	Thermal 1{1}	0	3	-4	0	3	-4
4	0						
	Thermal 2{1}	0	3	-3	0	3	-3
3	0						
	Thermal 3{1}	0	2	-2	0	2	-2
2	0						
	GRT1{1}	0	4	0	0	4	0
4	203						
	GRT2{1}	0	4	0	0	4	0
4	205						
	GRT3{1}	0	3	1	0	3	0
3	277						
A03 F- SIFI= 2.10 SIFO= 2.10							
	Gravity{1}	0	26	-26	1	26	-26
26	179						
	Hydrotest{1}	76	53	0	1	76	0
76	359						
	Thermal 1{1}	0	7	-7	0	7	-7
7	0						
	Thermal 2{1}	0	6	-6	0	6	-6
6	0						
	Thermal 3{1}	0	4	-4	0	4	-4
4	0						
	GRT1{1}	0	33	-33	1	33	-33
33	180						
	GRT2{1}	0	32	-32	1	33	-32
33	179						
	GRT3{1}	0	30	-30	1	30	-30
30	179						
A03 F+ SIFI= 2.10 SIFO= 2.10							
	Gravity{1}	0	26	-26	1	26	-26
26	359						
	Hydrotest{1}	76	53	0	1	76	0
76	179						
	Thermal 1{1}	0	7	-7	0	7	-7
7	180						

□

CIRCUITOPROVABARRE

07/30/2010 CIRCUITO PROVA BARRE
BENTLEY

02:16 PM

AutoPIPE Plus 9.2.1 RESULT PAGE 63

GENERAL PIPE STRESS REPORT

(Stress in N/mm2)

Point Total name Stress	Load combination Loc	Hoop	Longitudinal		Shear	Principal	
		Stress	Max	Min	Stress	Max	Min
6	Thermal 2{1}	0	6	-6	0	6	-6
	180						
4	Thermal 3{1}	0	4	-4	0	4	-4
	180						
	GRT1{1}	0	33	-33	1	33	-33

circuitoprovabarre.txt

33	359							
	GRT2{1}		0	32	-32	1	32	-32
33	359							
	GRT3{1}		0	30	-30	1	30	-30
30	359							
A00	SIFI= 1.00	SIFO= 1.00						
	Gravity{1}		0	13	-13	1	13	-13
13	359							
	Hydrotest{1}		76	39	14	1	76	14
71	179							
	Thermal 1{1}		0	3	-3	0	3	-3
3	180							
	Thermal 2{1}		0	3	-3	0	3	-3
3	180							
	Thermal 3{1}		0	2	-2	0	2	-2
2	180							
	GRT1{1}		0	16	-16	1	16	-16
16	359							
	GRT2{1}		0	16	-16	1	16	-16
16	359							
	GRT3{1}		0	14	-14	1	14	-14
14	359							
A25	SIFI= 1.00	SIFO= 1.00						
	Gravity{1}		0	20	-20	1	20	-20
20	360							
	Hydrotest{1}		76	46	7	1	76	7
73	180							
	Thermal 1{1}		0	3	-3	0	3	-3
3	180							
	Thermal 2{1}		0	3	-3	0	3	-3
3	180							
	Thermal 3{1}		0	2	-2	0	2	-2
2	180							
	GRT1{1}		0	23	-23	1	23	-23
23	360							
	GRT2{1}		0	22	-22	1	22	-22
22	360							
	GRT3{1}		0	21	-21	1	21	-21
21	360							
A01 -	SIFI= 2.10	SIFO= 2.10						
	Gravity{1}		0	34	-34	1	34	-34
34	0							
	Hydrotest{1}		76	61	-8	1	76	-8
81	180							
	Thermal 1{1}		0	7	-7	0	7	-7
7	180							
	Thermal 2{1}		0	6	-6	0	6	-6
6	180							
	Thermal 3{1}		0	4	-4	0	4	-4
4	180							
	GRT1{1}		0	41	-41	1	41	-41
41	0							
	GRT2{1}		0	40	-40	1	40	-40
40	0							
	GRT3{1}		0	38	-38	1	38	-38
38	0							
A01 +	SIFI= 2.10	SIFO= 2.10						
	Gravity{1}		0	27	-27	1	27	-27
27	0							
	Hydrotest{1}		76	53	-1	1	76	-1
77	180							
	Thermal 1{1}		0	0	0	0	0	0
0	0							
	Thermal 2{1}		0	2	-2	0	2	-2

circuitoprovabarre.txt

2	0							
	Thermal 3{1}	0	2	-2	0	2	-2	
2	180							
	GRT1{1}	0	27	-27	1	27	-27	
27	180							
	GRT2{1}	0	25	-25	1	25	-25	
25	180							
	GRT3{1}	0	29	-29	1	29	-29	
29	0							
A05	SIFI= 1.00 SIFO= 1.00							
	Gravity{1}	0	23	-23	1	23	-23	
23	360							
	Hydrotest{1}	76	49	4	1	76	4	
75	180							
	Thermal 1{1}	0	5	-6	0	5	-6	
6	180							
	Thermal 2{1}	0	2	-2	0	2	-2	
2	180							
	Thermal 3{1}	0	0	0	0	0	0	
0	180							

□

CIRCUITOPROVABARRE

07/30/2010 CIRCUITO PROVA BARRE
BENTLEY

02:16 PM

AutoPIPE Plus 9.2.1 RESULT PAGE 64

GENERAL PIPE STRESS REPORT

(Stress in N/mm2)

Point Total name Stress	Load combination Loc	Hoop Stress	Longitudinal		Shear Stress	Principal	
			Max	Min		Max	Min
28	GRT1{1}	0	28	-28	1	28	-28
	180						
25	GRT2{1}	0	25	-25	1	25	-25
	180						
23	GRT3{1}	0	23	-23	1	23	-23
	360						
A07	SIFI= 2.10 SIFO= 2.10						
	Gravity{1}	0	49	-49	1	49	-49
49	0						
	Hydrotest{1}	76	76	-23	1	77	-23
90	180						
	Thermal 1{1}	0	12	-12	0	12	-12
12	180						
	Thermal 2{1}	0	5	-5	0	5	-5
5	180						
	Thermal 3{1}	0	1	-1	0	1	-1
1	180						
	GRT1{1}	0	61	-61	1	61	-61
61	180						
	GRT2{1}	0	54	-54	1	54	-54
54	180						
	GRT3{1}	0	50	-50	1	50	-50
50	0						

circuitoprovabarre.txt

A07	+	SIFI= 2.10	SIFO= 2.10					
		Gravity{1}		0	49	-49	1	49
49		0						
		Hydrotest{1}		76	76	-23	1	77
90		180						
		Thermal 1{1}		0	12	-12	0	12
12		180						
		Thermal 2{1}		0	5	-5	0	5
5		180						
		Thermal 3{1}		0	1	-1	0	1
1		180						
		GRT1{1}		0	61	-61	1	61
61		180						
		GRT2{1}		0	54	-54	1	54
54		180						
		GRT3{1}		0	50	-50	1	50
50		0						
A26		SIFI= 1.00	SIFO= 1.00					
		Gravity{1}		0	24	-24	1	24
24		360						
		Hydrotest{1}		76	50	2	1	76
75		180						
		Thermal 1{1}		0	6	-6	0	6
6		180						
		Thermal 2{1}		0	2	-3	0	2
3		180						
		Thermal 3{1}		0	0	0	0	0
0		180						
		GRT1{1}		0	30	-30	1	30
30		180						
		GRT2{1}		0	26	-27	1	27
27		180						
		GRT3{1}		0	24	-24	1	24
25		360						
A08		SIFI= 1.00	SIFO= 1.00					
		Gravity{1}		0	14	-14	1	14
14		0						
		Hydrotest{1}		76	41	12	1	76
71		180						
		Thermal 1{1}		0	6	-6	0	6
6		180						
		Thermal 2{1}		0	3	-3	0	3
3		180						
		Thermal 3{1}		0	0	-1	0	0
1		180						
		GRT1{1}		0	20	-20	1	20
20		180						
		GRT2{1}		0	17	-17	1	17
17		180						
		GRT3{1}		0	15	-15	1	15
15		0						
A09	N-	SIFI= 1.00	SIFO= 1.00					
		Gravity{1}		0	14	-14	1	14
14		0						
		Hydrotest{1}		76	40	12	1	76
71		180						
		Thermal 1{1}		0	6	-6	0	6
6		180						
		Thermal 2{1}		0	3	-3	0	3
3		180						
		Thermal 3{1}		0	0	-1	0	0
1		180						
		GRT1{1}		0	20	-20	1	20
20		180						
		GRT2{1}		0	17	-17	1	17

□

CIRCUITOPROVABARRE

07/30/2010 CIRCUITO PROVA BARRE
BENTLEY

02:16 PM

AutoPIPE Plus 9.2.1 RESULT PAGE 65

GENERAL PIPE STRESS REPORT

(Stress in N/mm2)

Point Total name Stress	Load combination Loc	Hoop Stress	Longitudinal Max Min	Shear Stress	Principal Max Min
14	GRT3{1} 0	0	14 -14	1	14 -14
A09 N+	SIFI= 1.00 SIFO= 1.00 Gravity{1}	0	14 -14	1	14 -14
14	180				
71	Hydrotest{1} 0	76	40 13	1	76 13
6	Thermal 1{1} 0	0	6 -6	0	6 -6
3	Thermal 2{1} 0	0	3 -3	0	3 -3
1	Thermal 3{1} 0	0	0 -1	0	0 -1
20	GRT1{1} 180	0	20 -20	1	20 -20
17	GRT2{1} 180	0	17 -17	1	17 -17
15	GRT3{1} 180	0	14 -14	1	14 -14
A09 M	SIFI= 1.00 SIFO= 1.00 Gravity{1}	0	10 -4	1	10 -4
10	11				
68	Hydrotest{1} 191	76	36 23	1	76 23
6	Thermal 1{1} 0	0	6 -6	0	6 -6
3	Thermal 2{1} 0	0	3 -3	0	3 -3
1	Thermal 3{1} 0	0	1 -1	0	1 -1
5	GRT1{1} 64	0	4 2	1	5 0
7	GRT2{1} 20	0	7 -1	1	7 -1
9	GRT3{1} 12	0	9 -3	1	9 -3
A09 F-	SIFI= 1.00 SIFO= 1.00 Gravity{1}	0	19 -11	0	19 -11
19	7				
70	Hydrotest{1} 187	76	46 16	0	76 16
	Thermal 1{1}	0	6 -6	0	6 -6

circuitoprovabarre.txt

6	0							
	Thermal	2{1}	0	3	-3	0	3	-3
3	0							
	Thermal	3{1}	0	1	-1	0	1	-1
1	0							
	GRT1{1}		0	14	-5	0	14	-5
14	11							
	GRT2{1}		0	17	-8	0	17	-8
17	9							
	GRT3{1}		0	19	-10	0	19	-10
19	7							
A09	F+	SIFI= 1.00	SIFO= 1.00					
	Gravity{1}			0	19	-11	0	19
19	97							
	Hydrotest{1}		76	46	16	0	76	16
70	277							
	Thermal	1{1}	0	6	-6	0	6	-6
6	90							
	Thermal	2{1}	0	3	-3	0	3	-3
3	90							
	Thermal	3{1}	0	1	-1	0	1	-1
1	90							
	GRT1{1}		0	14	-5	0	14	-5
14	101							
	GRT2{1}		0	17	-8	0	17	-8
17	99							
	GRT3{1}		0	19	-10	0	19	-10
19	97							
A11		SIFI= 1.00	SIFO= 1.00					
	Gravity{1}			0	19	-11	0	19
19	97							
	Hydrotest{1}		76	46	16	0	76	16
70	277							
	Thermal	1{1}	0	6	-6	0	6	-6
6	90							
	Thermal	2{1}	0	3	-3	0	3	-3
3	90							
	Thermal	3{1}	0	1	-1	0	1	-1
1	90							
	GRT1{1}		0	14	-5	0	14	-5
14	101							
	GRT2{1}		0	17	-8	0	17	-8
17	99							
	GRT3{1}		0	19	-10	0	19	-10
19	97							

□

CIRCUITOPROVABARRE

07/30/2010 CIRCUITO PROVA BARRE
BENTLEY

02:16 PM

AutoPIPE Plus 9.2.1 RESULT PAGE 66

GENERAL PIPE STRESS REPORT

(Stress in N/mm2)

Point Total name Stress	Load combination Loc	Hoop Stress	Longitudinal Max Min	Shear Stress	Principal Max Min
----------------------------------	----------------------------	----------------	----------------------------	-----------------	-------------------------

 circuitprovabarre.txt

A10	-	SIFI= 2.10	SIFO= 2.10						
		Gravity{1}		0	36	-27	0	36	-27
36		174							
		Hydrotest{1}		76	62	-1	0	76	-1
77		354							
		Thermal 1{1}		0	11	-11	0	11	-11
11		180							
		Thermal 2{1}		0	5	-5	0	5	-5
5		180							
		Thermal 3{1}		0	1	-1	0	1	-1
1		180							
		GRT1{1}		0	24	-16	0	24	-16
24		170							
		GRT2{1}		0	30	-22	0	30	-22
30		172							
		GRT3{1}		0	34	-26	0	34	-26
34		173							
A10	+	SIFI= 2.10	SIFO= 2.10						
		Gravity{1}		0	24	-15	0	24	-15
24		168							
		Hydrotest{1}		76	50	11	0	76	11
71		347							
		Thermal 1{1}		0	22	-21	0	22	-21
22		0							
		Thermal 2{1}		0	22	-22	0	22	-22
22		0							
		Thermal 3{1}		0	6	-6	0	6	-6
6		0							
		GRT1{1}		0	9	0	0	9	0
9		62							
		GRT2{1}		0	9	0	0	9	0
9		60							
		GRT3{1}		0	18	-9	0	18	-9
18		162							
A12		SIFI= 1.00	SIFO= 1.00						
		Gravity{1}		0	14	-5	0	14	-5
14		102							
		Hydrotest{1}		76	40	22	0	76	22
68		282							
		Thermal 1{1}		0	10	-10	0	10	-10
10		270							
		Thermal 2{1}		0	10	-10	0	10	-10
10		270							
		Thermal 3{1}		0	3	-3	0	3	-3
3		270							
		GRT1{1}		0	7	2	0	7	0
7		206							
		GRT2{1}		0	7	2	0	7	0
7		210							
		GRT3{1}		0	11	-2	0	11	-2
11		107							
A13		SIFI= 1.00	SIFO= 1.00						
		Gravity{1}		0	13	-5	0	13	-5
13		100							
		Hydrotest{1}		76	40	22	0	76	22
68		280							
		Thermal 1{1}		0	9	-9	0	9	-9
9		270							
		Thermal 2{1}		0	10	-10	0	10	-10
10		270							
		Thermal 3{1}		0	3	-3	0	3	-3
3		270							
		GRT1{1}		0	6	3	0	6	0

circuitoprovabarre.txt

6	202		0	6	3	0	6	0
	GRT2{1}							
6	208		0	11	-2	0	11	-2
	GRT3{1}							
11	104							

*** Segment A end ***

*** Segment B begin ***

A01	SIFI= 2.10	SIFO= 2.10						
	Gravity{1}		0	71	-78	0	71	-78
78	14							
	Hydrotest{1}		49	84	-65	0	84	-65
99	14							
	Thermal 1{1}		0	65	-65	0	65	-65
65	180							
	Thermal 2{1}		0	76	-76	0	76	-76
76	180							
	Thermal 3{1}		0	13	-13	0	13	-13
13	180							
	GRT1{1}		0	135	-142	0	135	-142
142	8							
	GRT2{1}		0	145	-153	0	145	-153
153	7							

□

CIRCUITOPROVABARRE

07/30/2010 CIRCUITO PROVA BARRE
BENTLEY

02:16 PM

AutoPIPE Plus 9.2.1 RESULT PAGE 67

GENERAL PIPE STRESS REPORT

(Stress in N/mm2)

Point Total name Stress	Load combination Loc	Hoop Stress	Longitudinal		Shear Stress	Principal	
			Max	Min		Max	Min
91	GRT3{1} 12	0	84	-91	0	84	-91
B01	SIFI= 1.00	SIFO= 1.00					
	Gravity{1}	0	32	-40	0	32	-40
40	78						
	Hydrotest{1}	49	46	-27	0	49	-27
66	78						
	Thermal 1{1}	0	27	-27	0	27	-27
27	270						
	Thermal 2{1}	0	32	-32	0	32	-32
32	270						
	Thermal 3{1}	0	6	-6	0	6	-6
6	270						
	GRT1{1}	0	59	-66	0	59	-66
66	83						
	GRT2{1}	0	64	-71	0	64	-71
71	83						
	GRT3{1}	0	38	-45	0	38	-45
45	79						

circuitoprovabarre.txt

B02	SIFI= 2.00	SIFO= 2.00						
	Gravity{1}		0	69	-76	0	69	-76
76	79							
	Hydrotest{1}		49	83	-63	0	83	-63
98	79							
	Thermal 1{1}		0	49	-49	0	49	-49
49	270							
	Thermal 2{1}		0	57	-57	0	57	-57
57	270							
	Thermal 3{1}		0	10	-10	0	10	-10
10	270							
	GRT1{1}		0	117	-124	0	117	-124
124	83							
	GRT2{1}		0	125	-132	0	125	-132
132	84							
	GRT3{1}		0	79	-86	0	79	-86
86	80							
B03	SIFI= 2.00	SIFO= 2.00						
	Gravity{1}		0	13	-16	0	13	-16
16	80							
	Hydrotest{1}		75	39	9	0	75	9
70	80							
	Thermal 1{1}		0	9	-9	0	9	-9
9	270							
	Thermal 2{1}		0	10	-10	0	10	-10
10	270							
	Thermal 3{1}		0	2	-2	0	2	-2
2	270							
	GRT1{1}		0	22	-25	0	22	-25
25	84							
	GRT2{1}		0	23	-26	0	23	-26
26	84							
	GRT3{1}		0	15	-18	0	15	-18
18	81							
B04	SIFI= 2.00	SIFO= 2.00						
	Gravity{1}		0	4	-5	0	4	-5
5	81							
	Hydrotest{1}		86	35	26	0	86	26
77	81							
	Thermal 1{1}		0	2	-2	0	2	-2
2	270							
	Thermal 2{1}		0	3	-3	0	3	-3
3	270							
	Thermal 3{1}		0	0	0	0	0	0
0	270							
	GRT1{1}		0	6	-8	0	6	-8
8	84							
	GRT2{1}		0	7	-8	0	7	-8
8	85							
	GRT3{1}		0	4	-6	0	4	-6
6	82							
B09	SIFI= 1.00	SIFO= 1.00						
	Gravity{1}		0	2	-3	0	2	-3
3	90							
	Hydrotest{1}		86	33	28	0	86	28
76	90							
	Thermal 1{1}		0	0	0	0	0	0
0	270							
	Thermal 2{1}		0	0	0	0	0	0
0	270							
	Thermal 3{1}		0	0	0	0	0	0
0	270							
	GRT1{1}		0	2	-3	0	2	-3
3	90							
	GRT2{1}		0	2	-3	0	2	-3

circuitoprovabarre.txt

3 90
 GRT3{1} 0 2 -3 0 2 -3
 3 90

□

 CIRCUITOPROVABARRE

07/30/2010 CIRCUITO PROVA BARRE
 BENTLEY

02:16 PM

AutoPIPE Plus 9.2.1 RESULT PAGE 68

GENERAL PIPE STRESS REPORT

(Stress in N/mm2)

Point Total name Stress	Load combination Loc	Hoop Stress	Longitudinal		Shear Stress	Principal	
			Max	Min		Max	Min

B05	- SIFI= 2.10 SIFO= 2.10 Gravity{1}	0	5	-6	0	5	-6
6	0 Hydrotest{1}	86	36	26	0	86	26
77	0 Thermal 1{1}	0	0	0	0	0	0
0	270 Thermal 2{1}	0	0	0	0	0	0
0	270 Thermal 3{1}	0	0	0	0	0	0
0	270 GRT1{1}	0	5	-6	0	5	-6
6	0 GRT2{1}	0	5	-6	0	5	-6
6	0 GRT3{1}	0	5	-6	0	5	-6
6	0						
B05	+ SIFI= 2.10 SIFO= 2.10 Gravity{1}	0	0	0	0	0	0
0	270 Hydrotest{1}	86	31	31	0	86	31
76	270 Thermal 1{1}	0	0	0	0	0	0
0	90 Thermal 2{1}	0	0	0	0	0	0
0	90 Thermal 3{1}	0	0	0	0	0	0
0	90 GRT1{1}	0	0	0	0	0	0
0	270 GRT2{1}	0	0	0	0	0	0
0	270 GRT3{1}	0	0	0	0	0	0
0	270						
B10	SIFI= 1.00 SIFO= 1.00 Gravity{1}	0	0	0	0	0	0
0	270 Hydrotest{1}	86	31	31	0	86	31
76	270 Thermal 1{1}	0	0	0	0	0	0

circuitoprovabarre.txt

0	90						
	Thermal 2{1}		0	0	0	0	0
0	90						
	Thermal 3{1}		0	0	0	0	0
0	90						
	GRT1{1}		0	0	0	0	0
0	270						
	GRT2{1}		0	0	0	0	0
0	270						
	GRT3{1}		0	0	0	0	0
0	270						
B06	SIFI= 2.00	SIFO= 2.00					
	Gravity{1}		0	0	0	0	0
0	270						
	Hydrotest{1}		86	31	31	0	86 31
76	270						
	Thermal 1{1}		0	0	0	0	0
0	270						
	Thermal 2{1}		0	0	0	0	0
0	270						
	Thermal 3{1}		0	0	0	0	0
0	270						
	GRT1{1}		0	0	0	0	0
0	270						
	GRT2{1}		0	0	0	0	0
0	270						
	GRT3{1}		0	0	0	0	0
0	270						
B07	SIFI= 2.00	SIFO= 2.00					
	Gravity{1}		0	-1	-1	0	0 -1
1	270						
	Hydrotest{1}		82	28	28	0	82 28
72	270						
	Thermal 1{1}		0	0	0	0	0
0	270						
	Thermal 2{1}		0	0	0	0	0
0	270						
	Thermal 3{1}		0	0	0	0	0
0	270						
	GRT1{1}		0	-1	-1	0	0 -1
1	270						
	GRT2{1}		0	-1	-1	0	0 -1
1	270						
	GRT3{1}		0	-1	-1	0	0 -1
1	270						
B08	SIFI= 1.00	SIFO= 1.00					
	Gravity{1}		0	-1	-1	0	0 -1
1	270						

□

 CIRCUITOPROVABARRE

07/30/2010 CIRCUITO PROVA BARRE
 BENTLEY

02:16 PM

AutoPIPE Plus 9.2.1

RESULT PAGE 69

 G E N E R A L P I P E S T R E S S R E P O R T

(Stress in N/mm2)

Point	Load	Hoop	Longitudinal	Shear	Principal
-------	------	------	--------------	-------	-----------

circuitoprovabarre.txt

Total name Stress	combination Loc	Stress	Max	Min	Stress	Max	Min
72	Hydrotest{1} 270	82	29	29	0	82	29
0	Thermal 1{1} 270	0	0	0	0	0	0
0	Thermal 2{1} 270	0	0	0	0	0	0
0	Thermal 3{1} 270	0	0	0	0	0	0
1	GRT1{1} 270	0	-1	-1	0	0	-1
1	GRT2{1} 270	0	-1	-1	0	0	-1
1	GRT3{1} 270	0	-1	-1	0	0	-1

*** Segment B end ***

*** Segment C begin ***

A07	SIFI= 2.10 SIFO= 2.10 Gravity{1} 270	0	0	0	0	0	0
40	Hydrotest{1} 270	45	11	11	0	45	11
0	Thermal 1{1} 270	0	0	0	0	0	0
0	Thermal 2{1} 270	0	0	0	0	0	0
0	Thermal 3{1} 270	0	0	0	0	0	0
0	GRT1{1} 270	0	0	0	0	0	0
0	GRT2{1} 270	0	0	0	0	0	0
0	GRT3{1} 270	0	0	0	0	0	0

C01	SIFI= 1.00 SIFO= 1.00 Gravity{1} 270	0	0	0	0	0	0
40	Hydrotest{1} 270	45	11	11	0	45	11
0	Thermal 1{1} 270	0	0	0	0	0	0
0	Thermal 2{1} 270	0	0	0	0	0	0
0	Thermal 3{1} 270	0	0	0	0	0	0
0	GRT1{1} 270	0	0	0	0	0	0
0	GRT2{1} 270	0	0	0	0	0	0
0	GRT3{1} 270	0	0	0	0	0	0

*** Segment C end ***

*** Segment D begin ***

A10	SIFI= 2.10 SIFO= 2.10 Gravity{1}	0	73	-73	1	73	-73
73	1 Hydrotest{1}	82	103	-45	1	103	-45

circuitoprovabarre.txt

111	181							
	Thermal 1{1}	0	62	-62	0	62	-62	
62	180							
	Thermal 2{1}	0	100	-100	0	100	-100	
100	180							
	Thermal 3{1}	0	31	-31	0	31	-31	
31	180							
	GRT1{1}	0	134	-134	1	134	-134	
134	180							
	GRT2{1}	0	172	-172	1	172	-172	
172	180							
	GRT3{1}	0	104	-104	1	104	-104	
104	1							
D01	SIFI= 1.00 SIFO= 1.00							
	Gravity{1}	0	33	-33	1	33	-33	
33	179							
	Hydrotest{1}	82	62	-4	1	82	-4	
84	359							
	Thermal 1{1}	0	27	-27	0	27	-27	
27	0							
	Thermal 2{1}	0	43	-43	0	43	-43	
43	0							
	Thermal 3{1}	0	13	-13	0	13	-13	
13	0							

□

CIRCUITOPROVABARRE

07/30/2010 CIRCUITO PROVA BARRE
BENTLEY

02:16 PM

AutoPIPE Plus 9.2.1 RESULT PAGE 70

GENERAL PIPE STRESS REPORT

(Stress in N/mm2)

Point Total name Stress	Load combination Loc	Hoop	Longitudinal		Shear	Principal	
		Stress	Max	Min	Stress	Max	Min
---	---	---	---	---	---	---	---
59	GRT1{1}	0	59	-59	1	59	-59
	360						
76	GRT2{1}	0	76	-76	1	76	-76
	360						
46	GRT3{1}	0	46	-46	1	46	-46
	179						
D08	SIFI= 1.00 SIFO= 1.00						
	Gravity{1}	0	31	-31	1	31	-31
31	179						
	Hydrotest{1}	82	60	-2	1	82	-2
83	359						
	Thermal 1{1}	0	24	-24	0	24	-24
24	0						
	Thermal 2{1}	0	39	-39	0	39	-39
39	0						
	Thermal 3{1}	0	12	-12	0	12	-12
12	0						
	GRT1{1}	0	55	-55	1	55	-55
55	360						
	GRT2{1}	0	70	-70	1	70	-70

circuitoprovabarre.txt

70	360							
	GRT3{1}		0	43	-43	1	43	-43
43	179							
D02	SIFI= 1.00	SIFO= 1.00						
	Gravity{1}		0	7	-7	1	7	-7
7	179							
	Hydrotest{1}		82	36	23	1	82	23
73	359							
	Thermal 1{1}		0	4	-4	0	4	-4
4	180							
	Thermal 2{1}		0	9	-9	0	9	-9
9	180							
	Thermal 3{1}		0	3	-3	0	3	-3
3	180							
	GRT1{1}		0	2	-2	1	3	-3
3	358							
	GRT2{1}		0	2	-2	1	3	-3
3	182							
	GRT3{1}		0	3	-3	1	4	-4
4	179							
D03	- SIFI= 2.10	SIFO= 2.10						
	Gravity{1}		0	10	-10	1	10	-10
10	181							
	Hydrotest{1}		82	39	19	1	82	19
74	1							
	Thermal 1{1}		0	13	-13	0	13	-13
13	180							
	Thermal 2{1}		0	25	-25	0	25	-25
25	180							
	Thermal 3{1}		0	9	-9	0	9	-9
9	180							
	GRT1{1}		0	3	-3	1	4	-4
4	178							
	GRT2{1}		0	15	-15	1	15	-15
15	179							
	GRT3{1}		0	1	-1	1	2	-2
2	186							
D03	+ SIFI= 2.10	SIFO= 2.10						
	Gravity{1}		0	10	-10	1	10	-10
10	181							
	Hydrotest{1}		82	39	19	1	82	19
74	1							
	Thermal 1{1}		0	13	-13	0	13	-13
13	180							
	Thermal 2{1}		0	25	-25	0	25	-25
25	180							
	Thermal 3{1}		0	9	-9	0	9	-9
9	180							
	GRT1{1}		0	3	-3	1	4	-4
4	178							
	GRT2{1}		0	15	-15	1	15	-15
15	179							
	GRT3{1}		0	1	-1	1	2	-2
2	186							
D04	SIFI= 1.00	SIFO= 1.00						
	Gravity{1}		0	3	-3	1	3	-3
3	179							
	Hydrotest{1}		82	32	26	1	82	26
73	359							
	Thermal 1{1}		0	8	-8	0	8	-8
8	180							
	Thermal 2{1}		0	15	-15	0	15	-15
15	180							
	Thermal 3{1}		0	5	-5	0	5	-5

circuitoprovabarre.txt

5	180						
	GRT1{1}	0	5	-5	1	6	-6
6	181						
	GRT2{1}	0	12	-12	1	12	-12
12	180						

□

CIRCUITOPROVABARRE

07/30/2010 CIRCUITO PROVA BARRE
BENTLEY

02:16 PM

AutoPIPE Plus 9.2.1 RESULT PAGE 71

GENERAL PIPE STRESS REPORT

(Stress in N/mm2)

Point	Load	Hoop	Longitudinal		Shear	Principal	
Total	combination	Stress	Max	Min	Stress	Max	Min
name	Loc						
Stress							
3	GRT3{1}	0	2	-2	1	3	-3
	1						
D05 N-	SIFI= 1.00 SIFO= 1.00						
3	Gravity{1}	0	3	-3	1	3	-3
	179						
73	Hydrotest{1}	82	32	26	1	82	26
	359						
8	Thermal 1{1}	0	8	-8	0	8	-8
	180						
15	Thermal 2{1}	0	15	-15	0	15	-15
	180						
5	Thermal 3{1}	0	5	-5	0	5	-5
	180						
6	GRT1{1}	0	5	-5	1	6	-6
	180						
12	GRT2{1}	0	12	-12	1	12	-12
	180						
3	GRT3{1}	0	2	-2	1	3	-3
	1						
D05 N+	SIFI= 1.02 SIFO= 1.02						
3	Gravity{1}	0	3	-3	1	3	-3
	358						
73	Hydrotest{1}	82	32	26	1	82	26
	178						
8	Thermal 1{1}	0	8	-8	0	8	-8
	0						
15	Thermal 2{1}	0	15	-15	0	15	-15
	0						
5	Thermal 3{1}	0	5	-5	0	5	-5
	0						
6	GRT1{1}	0	5	-6	1	6	-6
	1						
13	GRT2{1}	0	12	-12	1	12	-13
	0						
3	GRT3{1}	0	2	-2	1	3	-3
	2						
D05 M	SIFI= 1.02 SIFO= 1.02						
	Gravity{1}	0	2	-2	1	2	-3

circuitoprovabarre.txt

3	135						
	Hydrotest{1}	82	31	27	1	82	27
73	131						
	Thermal 1{1}	0	9	-10	0	9	-10
10	0						
	Thermal 2{1}	0	17	-18	0	17	-18
18	0						
	Thermal 3{1}	0	6	-6	0	6	-6
6	0						
	GRT1{1}	0	8	-9	1	8	-9
9	11						
	GRT2{1}	0	15	-17	1	15	-17
17	6						
	GRT3{1}	0	4	-5	1	4	-5
5	20						
D05 F- SIFI= 1.02 SIFO= 1.02							
	Gravity{1}	0	2	-3	0	2	-3
3	113						
	Hydrotest{1}	82	31	27	0	82	27
73	108						
	Thermal 1{1}	0	10	-11	0	10	-11
11	0						
	Thermal 2{1}	0	18	-19	0	18	-19
19	0						
	Thermal 3{1}	0	6	-6	0	6	-6
6	0						
	GRT1{1}	0	9	-10	0	9	-10
10	13						
	GRT2{1}	0	17	-18	0	17	-18
18	7						
	GRT3{1}	0	5	-6	0	5	-6
6	22						
D05 F+ SIFI= 1.00 SIFO= 1.00							
	Gravity{1}	0	2	-3	0	2	-3
3	203						
	Hydrotest{1}	82	31	27	0	82	27
73	198						
	Thermal 1{1}	0	10	-10	0	10	-10
10	90						
	Thermal 2{1}	0	17	-19	0	17	-19
19	90						
	Thermal 3{1}	0	6	-6	0	6	-6
6	90						
	GRT1{1}	0	9	-10	0	9	-10
10	103						
	GRT2{1}	0	16	-18	0	16	-18
18	97						
	GRT3{1}	0	5	-6	0	5	-6
6	112						

□

 CIRCUITOPROVABARRE

07/30/2010 CIRCUITO PROVA BARRE
 BENTLEY

02:16 PM

AutoPIPE Plus 9.2.1

RESULT PAGE 72

 G E N E R A L P I P E S T R E S S R E P O R T

(Stress in N/mm2)

circuitoprovabarre.txt

Point Total name Stress	Load combination Loc	Hoop			Longitudinal		Shear Stress	Principal	
		Stress	Max	Min	Max	Min			

D06	SIFI= 1.00 SIFO= 1.00								
3	Gravity{1}	0	2	-3	0	2	-3		
73	203 Hydrotest{1}	82	31	27	0	82	27		
10	198 Thermal 1{1}	0	10	-10	0	10	-10		
19	90 Thermal 2{1}	0	17	-19	0	17	-19		
6	90 Thermal 3{1}	0	6	-6	0	6	-6		
10	90 GRT1{1}	0	9	-10	0	9	-10		
18	103 GRT2{1}	0	16	-18	0	16	-18		
6	97 GRT3{1}	0	5	-6	0	5	-6		
6	112								
D07	SIFI= 1.00 SIFO= 1.00								
2	Gravity{1}	0	2	-2	0	2	-2		
73	196 Hydrotest{1}	82	31	27	0	82	27		
10	192 Thermal 1{1}	0	9	-10	0	9	-10		
18	90 Thermal 2{1}	0	17	-18	0	17	-18		
6	90 Thermal 3{1}	0	6	-6	0	6	-6		
10	90 GRT1{1}	0	9	-10	0	9	-10		
18	103 GRT2{1}	0	16	-18	0	16	-18		
6	97 GRT3{1}	0	5	-6	0	5	-6		
6	112								
*** Segment D end ***									
*** Segment F begin ***									
A15	SIFI= 2.10 SIFO= 2.10								
14	Gravity{1}	0	14	-14	0	14	-14		
71	359 Hydrotest{1}	76	40	13	0	76	13		
44	179 Thermal 1{1}	0	43	-44	0	43	-44		
36	0 Thermal 2{1}	0	35	-36	0	35	-36		
12	0 Thermal 3{1}	0	12	-12	0	12	-12		
30	0 GRT1{1}	0	30	-30	0	30	-30		
22	1 GRT2{1}	0	21	-22	0	21	-22		
2	1 GRT3{1}	0	2	-2	0	2	-2		
2	352								
F01	SIFI= 1.00 SIFO= 1.00								
5	Gravity{1}	0	5	-5	0	5	-5		
	2 Hydrotest{1}	76	31	22	0	76	22		

circuitoprovabarre.txt

68	182							
	Thermal 1{1}	0	20	-21	0	20	-21	
21	0							
	Thermal 2{1}	0	16	-17	0	16	-17	
17	0							
	Thermal 3{1}	0	5	-6	0	5	-6	
6	0							
	GRT1{1}	0	16	-16	0	16	-16	
16	360							
	GRT2{1}	0	12	-12	0	12	-12	
12	359							
	GRT3{1}	0	1	-1	0	1	-1	
1	172							
F02	SIFI= 1.00 SIFO= 1.00							
	Gravity{1}	0	3	-2	0	3	-3	
3	178							
	Hydrotest{1}	76	29	24	0	76	24	
68	358							
	Thermal 1{1}	0	19	-19	0	19	-19	
19	0							
	Thermal 2{1}	0	15	-15	0	15	-15	
15	0							
	Thermal 3{1}	0	5	-5	0	5	-5	
5	0							
	GRT1{1}	0	21	-22	0	21	-22	
22	360							
	GRT2{1}	0	17	-18	0	17	-18	
18	360							

□

 CIRCUITOPROVABARRE

07/30/2010 CIRCUITO PROVA BARRE
 BENTLEY

02:16 PM

AutoPIPE Plus 9.2.1

RESULT PAGE 73

 G E N E R A L P I P E S T R E S S R E P O R T

(Stress in N/mm2)

Point Total name Stress	Load combination Loc	Hoop	Longitudinal		Shear	Principal	
		Stress	Max	Min	Stress	Max	Min
8	GRT3{1} 179	0	8	-8	0	8	-8
F13	SIFI= 2.10 SIFO= 2.10						
	Gravity{1}	0	8	-8	0	8	-8
8	1						
	Hydrotest{1}	76	35	18	0	76	18
69	181						
	Thermal 1{1}	0	36	-36	0	36	-36
36	180						
	Thermal 2{1}	0	28	-28	0	28	-28
28	180						
	Thermal 3{1}	0	11	-11	0	11	-11
11	180						
	GRT1{1}	0	44	-44	0	44	-44
44	180						
	GRT2{1}	0	35	-36	0	35	-36

circuitoprovabarre.txt

36	180							
	GRT3{1}		0	19	-19	0	19	-19
19	0							
F13	+ SIFI= 2.10	SIFO= 2.10						
	Gravity{1}		0	7	-7	0	7	-7
7	1							
	Hydrotest{1}		76	34	19	0	76	19
69	181							
	Thermal 1{1}		0	34	-34	0	34	-34
34	180							
	Thermal 2{1}		0	27	-27	0	27	-27
27	180							
	Thermal 3{1}		0	11	-11	0	11	-11
11	180							
	GRT1{1}		0	41	-41	0	41	-41
41	180							
	GRT2{1}		0	34	-34	0	34	-34
34	180							
	GRT3{1}		0	18	-18	0	18	-18
18	180							
F03	SIFI= 1.00	SIFO= 1.00						
	Gravity{1}		0	1	-1	0	1	-1
1	352							
	Hydrotest{1}		76	27	26	0	76	26
67	170							
	Thermal 1{1}		0	9	-10	0	9	-10
10	0							
	Thermal 2{1}		0	6	-6	0	6	-6
6	0							
	Thermal 3{1}		0	5	-5	0	5	-5
5	0							
	GRT1{1}		0	9	-9	0	9	-9
9	1							
	GRT2{1}		0	5	-5	0	5	-5
5	2							
	GRT3{1}		0	4	-4	0	4	-4
4	2							
F04	- SIFI= 2.10	SIFO= 2.10						
	Gravity{1}		0	3	-3	0	3	-3
3	185							
	Hydrotest{1}		76	29	24	0	76	24
68	6							
	Thermal 1{1}		0	19	-20	0	19	-20
20	180							
	Thermal 2{1}		0	11	-11	0	11	-11
11	180							
	Thermal 3{1}		0	9	-10	0	9	-10
10	180							
	GRT1{1}		0	16	-17	0	16	-17
17	179							
	GRT2{1}		0	8	-8	0	8	-8
8	178							
	GRT3{1}		0	6	-6	0	6	-6
6	177							
F04	+ SIFI= 2.10	SIFO= 2.10						
	Gravity{1}		0	3	-3	0	3	-3
3	185							
	Hydrotest{1}		76	29	24	0	76	24
68	6							
	Thermal 1{1}		0	19	-20	0	19	-20
20	180							
	Thermal 2{1}		0	11	-11	0	11	-11
11	180							
	Thermal 3{1}		0	9	-10	0	9	-10

circuitoprovabarre.txt

10	180							
	GRT1{1}	0	16	-17	0	16	-17	
17	179							
	GRT2{1}	0	8	-8	0	8	-8	
8	178							
	GRT3{1}	0	6	-6	0	6	-6	
6	177							

□

CIRCUITOPROVABARRE

07/30/2010 CIRCUITO PROVA BARRE
BENTLEY

02:16 PM

AutoPIPE Plus 9.2.1

RESULT PAGE 74

GENERAL PIPE STRESS REPORT

(Stress in N/mm2)

Point Total name Stress	Load combination Loc	Hoop Stress	Longitudinal		Shear Stress	Principal	
			Max	Min		Max	Min
F05	SIFI= 1.00 SIFO= 1.00 Gravity{1}	0	2	-2	0	2	-2
2	356						
68	Hydrotest{1}	76	28	24	0	76	24
	176						
9	Thermal 1{1}	0	9	-9	0	9	-9
	0						
5	Thermal 2{1}	0	5	-5	0	5	-5
	0						
5	Thermal 3{1}	0	4	-5	0	4	-5
	0						
7	GRT1{1}	0	7	-7	0	7	-7
	1						
3	GRT2{1}	0	3	-3	0	3	-3
	3						
2	GRT3{1}	0	2	-2	0	2	-2
	4						
F06 N-	SIFI= 1.00 SIFO= 1.00 Gravity{1}	0	2	-2	0	2	-2
2	356						
68	Hydrotest{1}	76	28	24	0	76	24
	176						
9	Thermal 1{1}	0	9	-9	0	9	-9
	0						
5	Thermal 2{1}	0	5	-5	0	5	-5
	0						
5	Thermal 3{1}	0	4	-5	0	4	-5
	0						
7	GRT1{1}	0	7	-7	0	7	-7
	1						
3	GRT2{1}	0	3	-3	0	3	-3
	3						
2	GRT3{1}	0	2	-2	0	2	-2
	4						
F06 N+	SIFI= 1.00 SIFO= 1.00 Gravity{1}	0	2	-2	0	2	-2

circuitoprovabarre.txt

2	356						
	Hydrotest{1}	76	28	24	0	76	24
68	175						
	Thermal 1{1}	0	9	-9	0	9	-9
9	0						
	Thermal 2{1}	0	5	-5	0	5	-5
5	0						
	Thermal 3{1}	0	4	-5	0	4	-5
5	0						
	GRT1{1}	0	7	-7	0	7	-7
7	1						
	GRT2{1}	0	3	-3	0	3	-3
3	3						
	GRT3{1}	0	2	-2	0	2	-2
2	4						
F06 M	SIFI= 1.00 SIFO= 1.00						
	Gravity{1}	0	3	-2	0	3	-2
3	348						
	Hydrotest{1}	76	29	24	0	76	24
68	168						
	Thermal 1{1}	0	8	-8	0	8	-8
8	0						
	Thermal 2{1}	0	4	-4	0	4	-4
4	0						
	Thermal 3{1}	0	4	-4	0	4	-4
4	0						
	GRT1{1}	0	6	-6	0	6	-6
6	185						
	GRT2{1}	0	2	-2	0	2	-2
2	197						
	GRT3{1}	0	2	-2	0	2	-2
2	196						
F06 F-	SIFI= 1.00 SIFO= 1.00						
	Gravity{1}	0	3	-2	0	3	-2
3	347						
	Hydrotest{1}	76	29	24	0	76	24
68	166						
	Thermal 1{1}	0	7	-7	0	7	-7
7	180						
	Thermal 2{1}	0	4	-3	0	4	-3
4	180						
	Thermal 3{1}	0	4	-4	0	4	-4
4	180						
	GRT1{1}	0	5	-5	0	5	-5
5	187						
	GRT2{1}	0	1	-1	0	1	-1
1	214						
	GRT3{1}	0	2	-1	0	2	-1
2	202						
F06 F+	SIFI= 1.00 SIFO= 1.00						
	Gravity{1}	0	3	-2	0	3	-2
3	257						

□

 CIRCUITOPROVABARRE

07/30/2010 CIRCUITO PROVA BARRE
 BENTLEY

02:16 PM

AutoPIPE Plus 9.2.1

RESULT PAGE 75

circuitoprovabarre.txt

(Stress in N/mm2)

Point Total name Stress	Load combination Loc	Hoop	Longitudinal		Shear	Principal	
		Stress	Max	Min	Stress	Max	Min
68	Hydrotest{1} 76	76	29	24	0	76	24
7	Thermal 1{1} 90	0	7	-7	0	7	-7
4	Thermal 2{1} 90	0	4	-3	0	4	-3
4	Thermal 3{1} 90	0	4	-4	0	4	-4
5	GRT1{1} 97	0	5	-5	0	5	-5
1	GRT2{1} 124	0	1	-1	0	1	-1
2	GRT3{1} 112	0	2	-1	0	2	-1
F07	SIFI= 1.00 SIFO= 1.00 Gravity{1}	0	3	-2	0	3	-2
3	257						
68	Hydrotest{1} 76	76	29	24	0	76	24
7	Thermal 1{1} 90	0	7	-7	0	7	-7
3	Thermal 2{1} 90	0	3	-3	0	3	-3
4	Thermal 3{1} 90	0	4	-4	0	4	-4
5	GRT1{1} 97	0	5	-5	0	5	-5
1	GRT2{1} 124	0	1	-1	0	1	-1
2	GRT3{1} 112	0	2	-1	0	2	-1
F08	SIFI= 1.00 SIFO= 1.00 Gravity{1}	0	2	-2	0	2	-2
2	252						
68	Hydrotest{1} 71	76	28	25	0	76	25
5	Thermal 1{1} 90	0	5	-5	0	5	-5
2	Thermal 2{1} 90	0	2	-1	0	2	-1
3	Thermal 3{1} 90	0	3	-3	0	3	-3
3	GRT1{1} 102	0	3	-3	0	3	-3
1	GRT2{1} 210	0	1	-1	0	1	-1
2	GRT3{1} 116	0	2	-1	0	2	-1
F09	SIFI= 1.00 SIFO= 1.00 Gravity{1}	0	2	0	0	2	0
2	166						
67	Hydrotest{1} 346	76	28	27	0	76	27
3	Thermal 1{1} 270	0	3	-3	0	3	-3
	Thermal 2{1}	0	5	-5	0	5	-5

circuitoprovabarre.txt

5	270	Thermal 3{1}	0	1	-1	0	1	-1
1	90	GRT1{1}	0	4	-2	0	4	-2
4	258	GRT2{1}	0	6	-4	0	6	-4
6	261	GRT3{1}	0	2	0	0	2	0
2	135							
F16	SIFI= 1.00	SIFO= 1.00						
	Gravity{1}		0	5	-3	0	5	-3
5	101	Hydrotest{1}	76	31	23	0	76	23
68	282	Thermal 1{1}	0	18	-18	0	18	-18
18	270	Thermal 2{1}	0	16	-16	0	16	-16
16	270	Thermal 3{1}	0	4	-4	0	4	-4
4	270	GRT1{1}	0	15	-13	0	15	-13
15	267	GRT2{1}	0	13	-11	0	13	-11
13	266	GRT3{1}	0	2	0	0	2	0
2	208							
F10	SIFI= 1.00	SIFO= 1.00						
	Gravity{1}		0	5	-3	0	5	-3
5	128	Hydrotest{1}	76	31	24	0	76	24
68	309	Thermal 1{1}	0	16	-16	0	16	-16
16	270							

□

 CIRCUITOPROVABARRE

07/30/2010 CIRCUITO PROVA BARRE
 BENTLEY

02:16 PM

AutoPIPE Plus 9.2.1 RESULT PAGE 76

 G E N E R A L P I P E S T R E S S R E P O R T

(Stress in N/mm2)

Point Total name Stress	Load combination Loc	Hoop	Longitudinal		Shear	Principal	
		Stress	Max	Min	Stress	Max	Min
14	Thermal 2{1}	0	14	-14	0	14	-14
4	270 Thermal 3{1}	0	4	-4	0	4	-4
14	270 GRT1{1}	0	14	-12	0	14	-12
12	260 GRT2{1}	0	12	-10	0	12	-10
4	258 GRT3{1}	0	4	-1	0	4	-1
	202						

circuitoprovabarre.txt

F11 - SIFI= 1.00 SIFO= 1.00
 7 Gravity{1} 0 7 -5 0 7 -5
 177
 68 Hydrotest{1} 76 34 22 0 76 22
 358
 10 Thermal 1{1} 0 10 -10 0 10 -10
 270
 9 Thermal 2{1} 0 9 -9 0 9 -9
 270
 2 Thermal 3{1} 0 2 -2 0 2 -2
 270
 13 GRT1{1} 0 13 -10 0 13 -10
 239
 12 GRT2{1} 0 12 -9 0 12 -9
 235
 8 GRT3{1} 0 8 -5 0 8 -5
 199

F11 + SIFI= 1.00 SIFO= 1.00
 15 Gravity{1} 0 15 -7 0 15 -7
 2
 69 Hydrotest{1} 76 41 19 0 76 19
 181
 10 Thermal 1{1} 0 10 -10 0 10 -10
 270
 9 Thermal 2{1} 0 9 -9 0 9 -9
 270
 2 Thermal 3{1} 0 2 -2 0 2 -2
 270
 19 GRT1{1} 0 19 -11 0 19 -11
 318
 18 GRT2{1} 0 18 -10 0 18 -10
 323
 15 GRT3{1} 0 15 -8 0 15 -8
 350

A13 SIFI= 1.00 SIFO= 1.00
 13 Gravity{1} 0 13 -5 0 13 -5
 260
 68 Hydrotest{1} 76 39 22 0 76 22
 80
 9 Thermal 1{1} 0 9 -9 0 9 -9
 90
 10 Thermal 2{1} 0 10 -10 0 10 -10
 90
 3 Thermal 3{1} 0 3 -3 0 3 -3
 90
 6 GRT1{1} 0 6 3 0 6 0
 158
 6 GRT2{1} 0 6 3 0 6 0
 152
 10 GRT3{1} 0 10 -2 0 10 -2
 256

*** Segment F end ***

*** Segment G begin ***

F04 SIFI= 2.10 SIFO= 2.10
 0 Gravity{1} 0 0 0 0 0 0
 270
 40 Hydrotest{1} 45 11 11 0 45 11
 270
 0 Thermal 1{1} 0 0 0 0 0 0
 270
 0 Thermal 2{1} 0 0 0 0 0 0
 270
 0 Thermal 3{1} 0 0 0 0 0 0

circuitoprovabarre.txt

0	270							
	GRT1{1}		0	0	0	0	0	0
0	270							
	GRT2{1}		0	0	0	0	0	0
0	270							
	GRT3{1}		0	0	0	0	0	0
0	270							
G01	SIFI= 1.00	SIFO= 1.00						
	Gravity{1}		0	0	0	0	0	0
0	270							

□

CIRCUITOPROVABARRE

07/30/2010 CIRCUITO PROVA BARRE
BENTLEY

02:16 PM

AutoPIPE Plus 9.2.1 RESULT PAGE 77

GENERAL PIPE STRESS REPORT

(Stress in N/mm2)

Point Total name Stress	Load combination Loc	Hoop	Longitudinal		Shear	Principal	
		Stress	Max	Min	Stress	Max	Min
40	Hydrotest{1}	45	11	11	0	45	11
	270						
0	Thermal 1{1}	0	0	0	0	0	0
	270						
0	Thermal 2{1}	0	0	0	0	0	0
	270						
0	Thermal 3{1}	0	0	0	0	0	0
	270						
0	GRT1{1}	0	0	0	0	0	0
	270						
0	GRT2{1}	0	0	0	0	0	0
	270						
0	GRT3{1}	0	0	0	0	0	0
	270						

*** Segment G end ***

*** Segment H begin ***

F13	SIFI= 2.10	SIFO= 2.10					
	Gravity{1}		0	31	-31	0	31
31	180						
65	Hydrotest{1}		56	49	-15	0	56
	360						
88	Thermal 1{1}		0	88	-88	0	88
	0						
36	Thermal 2{1}		0	35	-36	0	35
	0						
1	Thermal 3{1}		0	1	-1	0	1
	0						
119	GRT1{1}		0	119	-119	0	119
	180						
67	GRT2{1}		0	67	-66	0	67
	180						
	GRT3{1}		0	30	-29	0	30

circuitoprovabarre.txt

30 180

H01 N- SIFI= 1.00 SIFO= 1.00

12	269	Gravity{1}	0	12	-12	0	12	-12
54	89	Hydrotest{1}	56	28	6	0	56	6
41	270	Thermal 1{1}	0	41	-41	0	41	-41
19	270	Thermal 2{1}	0	19	-19	0	19	-19
1	90	Thermal 3{1}	0	1	-1	0	1	-1
29	270	GRT1{1}	0	29	-29	0	29	-29
7	91	GRT2{1}	0	7	-7	0	7	-7
11	269	GRT3{1}	0	11	-11	0	11	-11

H01 N+ SIFI= 1.00 SIFO= 1.00

12	359	Gravity{1}	0	12	-12	0	12	-12
54	179	Hydrotest{1}	56	28	6	0	56	6
41	0	Thermal 1{1}	0	41	-41	0	41	-41
19	0	Thermal 2{1}	0	19	-19	0	19	-19
1	180	Thermal 3{1}	0	1	-1	0	1	-1
29	0	GRT1{1}	0	29	-29	0	29	-29
7	181	GRT2{1}	0	7	-7	0	7	-7
11	359	GRT3{1}	0	11	-11	0	11	-11

H01 M SIFI= 1.00 SIFO= 1.00

13	360	Gravity{1}	0	13	-12	0	13	-12
54	180	Hydrotest{1}	56	29	5	0	56	5
41	0	Thermal 1{1}	0	41	-41	0	41	-41
19	0	Thermal 2{1}	0	19	-19	0	19	-19
1	0	Thermal 3{1}	0	1	-1	0	1	-1
29	180	GRT1{1}	0	29	-28	0	29	-28
7	181	GRT2{1}	0	7	-6	0	7	-6
12	360	GRT3{1}	0	12	-11	0	12	-11

□

 CIRCUITOPROVABARRE

07/30/2010 CIRCUITO PROVA BARRE
 BENTLEY

02:16 PM

AutoPIPE Plus 9.2.1

RESULT PAGE 78

circuitoprovabarre.txt
 GENERAL PIPE STRESS REPORT

(Stress in N/mm2)

Point Total name Stress	Load combination Loc	Hoop Stress	Longitudinal Max	Min	Shear Stress	Principal Max	Min

H01 F-	SIFI= 1.00 SIFO= 1.00						
13	Gravity{1}	0	13	-12	0	13	-12
54	Hydrotest{1}	56	29	5	0	56	5
40	Thermal 1{1}	0	40	-40	0	40	-40
19	Thermal 2{1}	0	19	-19	0	19	-19
1	Thermal 3{1}	0	1	-1	0	1	-1
28	GRT1{1}	0	28	-28	0	28	-28
7	GRT2{1}	0	7	-6	0	7	-6
12	GRT3{1}	0	12	-11	0	12	-11

H01 F+	SIFI= 1.00 SIFO= 1.00						
13	Gravity{1}	0	13	-12	0	13	-12
54	Hydrotest{1}	56	29	5	0	56	5
40	Thermal 1{1}	0	40	-40	0	40	-40
19	Thermal 2{1}	0	19	-19	0	19	-19
1	Thermal 3{1}	0	1	-1	0	1	-1
28	GRT1{1}	0	28	-28	0	28	-28
7	GRT2{1}	0	7	-6	0	7	-6
12	GRT3{1}	0	12	-11	0	12	-11

H02	SIFI= 1.00 SIFO= 1.00						
2	Gravity{1}	0	2	-2	0	2	-2
51	Hydrotest{1}	56	19	15	0	56	15
29	Thermal 1{1}	0	29	-29	0	29	-29
13	Thermal 2{1}	0	13	-13	0	13	-13
1	Thermal 3{1}	0	1	-1	0	1	-1
31	GRT1{1}	0	31	-31	0	31	-31
15	GRT2{1}	0	15	-14	0	15	-14
1	GRT3{1}	0	1	-1	0	1	-1

H03 -	SIFI= 2.10 SIFO= 2.10						
5	Gravity{1}	0	5	-5	0	5	-5
	Hydrotest{1}	56	23	11	0	56	11

circuitoprovabarre.txt

52	3	Thermal 1{1}	0	61	-61	0	61	-61
61	180	Thermal 2{1}	0	27	-27	0	27	-27
27	0	Thermal 3{1}	0	3	-3	0	3	-3
3	180	GRT1{1}	0	67	-66	0	67	-66
67	180	GRT2{1}	0	32	-32	0	32	-32
32	181	GRT3{1}	0	3	-2	0	3	-2
3	188							
H03 + SIFI= 2.10 SIFO= 2.10								
		Gravity{1}	0	5	-5	0	5	-5
5	184	Hydrotest{1}	56	23	11	0	56	11
52	3	Thermal 1{1}	0	61	-61	0	61	-61
61	180	Thermal 2{1}	0	27	-27	0	27	-27
27	0	Thermal 3{1}	0	3	-3	0	3	-3
3	180	GRT1{1}	0	67	-66	0	67	-66
67	180	GRT2{1}	0	32	-32	0	32	-32
32	181	GRT3{1}	0	3	-2	0	3	-2
3	188							
H04 SIFI= 1.00 SIFO= 1.00								
		Gravity{1}	0	3	-3	0	3	-3
3	357							

□

 CIRCUITOPROVABARRE

07/30/2010 CIRCUITO PROVA BARRE
 BENTLEY

02:16 PM

AutoPIPE Plus 9.2.1 RESULT PAGE 79

 G E N E R A L P I P E S T R E S S R E P O R T

(Stress in N/mm2)

Point Total name Stress	Load combination Loc	Hoop	Longitudinal		Shear	Principal	
		Stress	Max	Min	Stress	Max	Min
51	Hydrotest{1}	56	20	14	0	56	14
30	177 Thermal 1{1}	0	30	-30	0	30	-30
13	0 Thermal 2{1}	0	13	-13	0	13	-13
1	180 Thermal 3{1}	0	1	-1	0	1	-1
33	0 GRT1{1}	0	33	-32	0	33	-32
	360 GRT2{1}	0	16	-16	0	16	-16

circuitoprovabarre.txt

16	359							
	GRT3{1}		0	2	-1	0	2	-1
2	354							
H12	SIFI= 1.00	SIFO= 1.00						
	Gravity{1}		0	5	-5	0	5	-5
5	358							
	Hydrotest{1}		56	23	11	0	56	11
52	178							
	Thermal 1{1}		0	32	-32	0	32	-32
32	0							
	Thermal 2{1}		0	14	-14	0	14	-14
14	180							
	Thermal 3{1}		0	1	-1	0	1	-1
1	0							
	GRT1{1}		0	38	-37	0	38	-37
38	360							
	GRT2{1}		0	20	-19	0	20	-19
20	360							
	GRT3{1}		0	4	-4	0	4	-4
4	358							
H05 N-	SIFI= 1.00	SIFO= 1.00						
	Gravity{1}		0	8	-7	0	8	-7
8	359							
	Hydrotest{1}		56	25	9	0	56	9
52	179							
	Thermal 1{1}		0	34	-34	0	34	-34
34	0							
	Thermal 2{1}		0	15	-15	0	15	-15
15	180							
	Thermal 3{1}		0	1	-1	0	1	-1
1	0							
	GRT1{1}		0	42	-42	0	42	-42
42	360							
	GRT2{1}		0	23	-22	0	23	-22
23	360							
	GRT3{1}		0	6	-6	0	6	-6
6	358							
H05 N+	SIFI= 1.00	SIFO= 1.00						
	Gravity{1}		0	8	-7	0	8	-7
8	359							
	Hydrotest{1}		56	25	9	0	56	9
52	179							
	Thermal 1{1}		0	34	-34	0	34	-34
34	0							
	Thermal 2{1}		0	15	-15	0	15	-15
15	180							
	Thermal 3{1}		0	1	-1	0	1	-1
1	0							
	GRT1{1}		0	42	-42	0	42	-42
42	360							
	GRT2{1}		0	23	-22	0	23	-22
23	360							
	GRT3{1}		0	6	-6	0	6	-6
6	358							
H05 M	SIFI= 1.00	SIFO= 1.00						
	Gravity{1}		0	8	-7	0	8	-7
8	360							
	Hydrotest{1}		56	25	9	0	56	9
52	180							
	Thermal 1{1}		0	35	-35	0	35	-35
35	0							
	Thermal 2{1}		0	15	-15	0	15	-15
15	0							
	Thermal 3{1}		0	1	-1	0	1	-1

circuitoprovabarre.txt

1	0						
	GRT1{1}	0	43	-42	0	43	-42
43	360						
	GRT2{1}	0	23	-23	0	23	-23
23	360						
	GRT3{1}	0	6	-6	0	6	-6
6	360						
H05 F-	SIFI= 1.00 SIFO= 1.00						
	Gravity{1}	0	7	-7	0	7	-7
7	1						
	Hydrotest{1}	56	24	10	0	56	10
52	181						
	Thermal 1{1}	0	35	-35	0	35	-35
35	0						

□

CIRCUITOPROVABARRE

07/30/2010 CIRCUITO PROVA BARRE
BENTLEY

02:16 PM

AutoPIPE Plus 9.2.1 RESULT PAGE 80

GENERAL PIPE STRESS REPORT

(Stress in N/mm2)

Point Total name Stress	Load combination Loc	Hoop Stress	Longitudinal		Shear Stress	Principal	
			Max	Min		Max	Min
16	Thermal 2{1}	0	16	-15	0	16	-15
1	0						
42	Thermal 3{1}	0	1	-1	0	1	-1
1	0						
42	GRT1{1}	0	42	-41	0	42	-41
0							
22	GRT2{1}	0	22	-22	0	22	-22
0							
6	GRT3{1}	0	6	-5	0	6	-5
2							
H05 F+	SIFI= 1.00 SIFO= 1.00						
	Gravity{1}	0	7	-7	0	7	-7
7	271						
	Hydrotest{1}	56	24	10	0	56	10
52	91						
	Thermal 1{1}	0	35	-35	0	35	-35
35	270						
16	Thermal 2{1}	0	16	-15	0	16	-15
16	270						
1	Thermal 3{1}	0	1	-1	0	1	-1
1	270						
42	GRT1{1}	0	42	-41	0	42	-41
270							
22	GRT2{1}	0	22	-22	0	22	-22
270							
6	GRT3{1}	0	6	-5	0	6	-5
272							
H06	SIFI= 2.00 SIFO= 2.00						
	Gravity{1}	0	83	-83	0	83	-83

circuitoprovabarre.txt

83	90						
	Hydrotest{1}	56	99	-65	0	99	-65
106	270						
	Thermal 1{1}	0	66	-66	0	66	-66
66	270						
	Thermal 2{1}	0	39	-39	0	39	-39
39	270						
	Thermal 3{1}	0	4	-4	0	4	-4
4	90						
	GRT1{1}	0	17	-17	0	17	-17
17	89						
	GRT2{1}	0	44	-44	0	44	-44
44	90						
	GRT3{1}	0	80	-79	0	80	-79
80	90						
H07	SIFI= 2.00	SIFO= 2.00					
	Gravity{1}	0	15	-14	0	15	-14
15	90						
	Hydrotest{1}	82	44	15	0	82	15
76	270						
	Thermal 1{1}	0	10	-10	0	10	-10
10	270						
	Thermal 2{1}	0	6	-6	0	6	-6
6	270						
	Thermal 3{1}	0	1	-1	0	1	-1
1	90						
	GRT1{1}	0	4	-4	0	4	-4
4	90						
	GRT2{1}	0	8	-8	0	8	-8
8	90						
	GRT3{1}	0	14	-14	0	14	-14
14	90						
H08	SIFI= 1.00	SIFO= 1.00					
	Gravity{1}	0	8	-8	0	8	-8
8	90						
	Hydrotest{1}	82	37	21	0	82	21
74	270						
	Thermal 1{1}	0	5	-5	0	5	-5
5	270						
	Thermal 2{1}	0	3	-3	0	3	-3
3	270						
	Thermal 3{1}	0	0	0	0	0	0
0	90						
	GRT1{1}	0	3	-3	0	3	-3
3	90						
	GRT2{1}	0	5	-5	0	5	-5
5	90						
	GRT3{1}	0	8	-8	0	8	-8
8	90						
H09	SIFI= 1.00	SIFO= 1.00					
	Gravity{1}	0	33	-34	0	33	-34
34	90						
	Hydrotest{1}	82	50	-17	0	82	-17
92	90						
	Thermal 1{1}	0	5	-5	0	5	-5
5	270						
	Thermal 2{1}	0	3	-4	0	3	-4
4	90						
	Thermal 3{1}	0	0	-1	0	0	-1
1	90						

□

CIRCUITOPROVABARRE

GENERAL PIPE STRESS REPORT

(Stress in N/mm2)

Point Total name Stress	Load combination Loc	Hoop Stress	Longitudinal Max Min	Shear Stress	Principal Max Min
---	---				
39	GRT1{1} 90	0	38 -39	0	38 -39
38	GRT2{1} 90	0	36 -38	0	36 -38
35	GRT3{1} 90	0	33 -35	0	33 -35
H17	SIFI= 1.00 SIFO= 1.00				
11	Gravity{1} 270	0	10 -11	0	10 -11
79	Hydrotest{1} 270	82	27 6	0	82 6
3	Thermal 1{1} 270	0	3 -3	0	3 -3
8	Thermal 2{1} 90	0	7 -8	0	7 -8
4	Thermal 3{1} 90	0	3 -4	0	3 -4
7	GRT1{1} 270	0	7 -7	0	7 -7
4	GRT2{1} 271	0	2 -4	0	2 -4
8	GRT3{1} 270	0	6 -8	0	6 -8
H10 -	SIFI= 1.00 SIFO= 1.00				
10	Gravity{1} 269	0	9 -10	0	9 -10
79	Hydrotest{1} 269	82	26 7	0	82 7
2	Thermal 1{1} 270	0	2 -2	0	2 -2
5	Thermal 2{1} 90	0	4 -5	0	4 -5
3	Thermal 3{1} 90	0	2 -3	0	2 -3
7	GRT1{1} 269	0	7 -7	0	7 -7
5	GRT2{1} 268	0	4 -5	0	4 -5
7	GRT3{1} 269	0	6 -7	0	6 -7
H10 +	SIFI= 1.00 SIFO= 1.00				
11	Gravity{1} 89	0	11 -8	0	11 -8
78	Hydrotest{1} 269	82	28 9	0	82 9
2	Thermal 1{1} 270	0	2 -2	0	2 -2
	Thermal 2{1}	0	4 -5	0	4 -5

circuitoprovabarre.txt

5	90							
	Thermal 3{1}	0	2	-3	0	2	-3	
3	90							
	GRT1{1}	0	9	-6	0	9	-6	
9	89							
	GRT2{1}	0	5	-4	0	5	-4	
5	88							
	GRT3{1}	0	8	-6	0	8	-6	
8	89							
H20 - SIFI= 1.00 SIFO= 1.00								
	Gravity{1}	0	4	0	0	4	0	
4	350							
	Hydrotest{1}	82	21	17	0	82	17	
75	175							
	Thermal 1{1}	0	9	-9	0	9	-9	
9	90							
	Thermal 2{1}	0	16	-17	0	16	-17	
17	270							
	Thermal 3{1}	0	5	-6	0	5	-6	
6	270							
	GRT1{1}	0	11	-7	0	11	-7	
11	77							
	GRT2{1}	0	18	-15	0	18	-15	
18	83							
	GRT3{1}	0	7	-4	0	7	-4	
7	69							
H20 + SIFI= 1.00 SIFO= 1.00								
	Gravity{1}	0	1	-3	0	1	-3	
3	260							
	Hydrotest{1}	82	31	26	0	82	26	
73	265							
	Thermal 1{1}	0	9	-10	0	9	-10	
10	0							
	Thermal 2{1}	0	16	-17	0	16	-17	
17	0							
	Thermal 3{1}	0	5	-6	0	5	-6	
6	0							
	GRT1{1}	0	8	-10	0	8	-10	
10	347							
	GRT2{1}	0	15	-18	0	15	-18	
18	353							

□

CIRCUITOPROVABARRE

07/30/2010 CIRCUITO PROVA BARRE
BENTLEY

02:16 PM

AutoPIPE Plus 9.2.1 RESULT PAGE 82

GENERAL PIPE STRESS REPORT

(Stress in N/mm2)

Point Total name Stress	Load combination Loc	Hoop	Longitudinal		Shear	Principal	
		Stress	Max	Min	Stress	Max	Min
6	GRT3{1} 339	0	5	-6	0	5	-6

circuitoprovabarre.txt

D07	SIFI= 1.00	SIFO= 1.00						
	Gravity{1}		0	2	-3	0	2	-3
3	254							
	Hydrotest{1}		82	31	26	0	82	26
73	258							
	Thermal 1{1}		0	9	-10	0	9	-10
10	0							
	Thermal 2{1}		0	17	-18	0	17	-18
18	0							
	Thermal 3{1}		0	6	-6	0	6	-6
6	0							
	GRT1{1}		0	8	-10	0	8	-10
10	347							
	GRT2{1}		0	16	-18	0	16	-18
18	353							
	GRT3{1}		0	5	-6	0	5	-6
6	338							

*** Segment H end ***

*** Segment I begin ***

H03	SIFI= 2.10	SIFO= 2.10						
	Gravity{1}		0	0	0	0	0	0
0	270							
	Hydrotest{1}		56	17	17	0	56	17
50	270							
	Thermal 1{1}		0	0	0	0	0	0
0	270							
	Thermal 2{1}		0	0	0	0	0	0
0	270							
	Thermal 3{1}		0	0	0	0	0	0
0	270							
	GRT1{1}		0	0	0	0	0	0
0	270							
	GRT2{1}		0	0	0	0	0	0
0	270							
	GRT3{1}		0	0	0	0	0	0
0	270							

I02	SIFI= 1.00	SIFO= 1.00						
	Gravity{1}		0	0	0	0	0	0
0	270							
	Hydrotest{1}		56	17	17	0	56	17
50	270							
	Thermal 1{1}		0	0	0	0	0	0
0	270							
	Thermal 2{1}		0	0	0	0	0	0
0	270							
	Thermal 3{1}		0	0	0	0	0	0
0	90							
	GRT1{1}		0	0	0	0	0	0
0	270							
	GRT2{1}		0	0	0	0	0	0
0	270							
	GRT3{1}		0	0	0	0	0	0
0	270							

I01	SIFI= 1.00	SIFO= 1.00						
	Gravity{1}		0	0	0	0	0	0
0	270							
	Hydrotest{1}		56	17	17	0	56	17
50	270							
	Thermal 1{1}		0	0	0	0	0	0
0	270							
	Thermal 2{1}		0	0	0	0	0	0
0	270							
	Thermal 3{1}		0	0	0	0	0	0

circuitoprovabarre.txt

0	90						
	GRT1{1}	0	0	0	0	0	0
0	270						
	GRT2{1}	0	0	0	0	0	0
0	270						
	GRT3{1}	0	0	0	0	0	0
0	90						

*** Segment I end ***

*** Segment J begin ***

B05	SIFI= 2.10	SIFO= 2.10					
	Gravity{1}		0	54	-54	0	54 -54
54	0						

□

CIRCUITOPROVABARRE

07/30/2010 CIRCUITO PROVA BARRE
BENTLEY

02:16 PM

AutoPIPE Plus 9.2.1 RESULT PAGE 83

GENERAL PIPE STRESS REPORT

(Stress in N/mm2)

Point Total name Stress	Load combination Loc	Hoop Stress	Longitudinal		Shear Stress	Principal	
			Max	Min		Max	Min
97	Hydrotest{1}	82	83	-25	0	83	-25
	180						
0	Thermal 1{1}	0	0	0	0	0	0
	270						
0	Thermal 2{1}	0	0	0	0	0	0
	270						
0	Thermal 3{1}	0	0	0	0	0	0
	270						
54	GRT1{1}	0	54	-54	0	54	-54
	0						
54	GRT2{1}	0	54	-54	0	54	-54
	0						
54	GRT3{1}	0	54	-54	0	54	-54
	0						
J01	SIFI= 1.00	SIFO= 1.00					
	Gravity{1}	0	2	-2	0	2	-2
2	0						
72	Hydrotest{1}	82	31	27	0	82	27
	180						
0	Thermal 1{1}	0	0	0	0	0	0
	270						
0	Thermal 2{1}	0	0	0	0	0	0
	270						
0	Thermal 3{1}	0	0	0	0	0	0
	90						
2	GRT1{1}	0	2	-2	0	2	-2
	0						
2	GRT2{1}	0	2	-2	0	2	-2
	0						
2	GRT3{1}	0	2	-2	0	2	-2
	0						

circuitprovabarre.txt

2	0						
J02	N-	SIFI= 1.00	SIFO= 1.00				
		Gravity{1}		0	2	-2	0 2 -2
2	0	Hydrotest{1}		82	31	27	0 82 27
72	180	Thermal 1{1}		0	0	0	0 0 0
0	270	Thermal 2{1}		0	0	0	0 0 0
0	270	Thermal 3{1}		0	0	0	0 0 0
0	90	GRT1{1}		0	2	-2	0 2 -2
2	0	GRT2{1}		0	2	-2	0 2 -2
2	0	GRT3{1}		0	2	-2	0 2 -2
2	0						
J02	N+	SIFI= 1.02	SIFO= 1.02				
		Gravity{1}		0	2	-2	0 2 -2
2	180	Hydrotest{1}		82	31	27	0 82 27
72	180	Thermal 1{1}		0	0	0	0 0 0
0	270	Thermal 2{1}		0	0	0	0 0 0
0	270	Thermal 3{1}		0	0	0	0 0 0
0	270	GRT1{1}		0	2	-2	0 2 -2
2	180	GRT2{1}		0	2	-2	0 2 -2
2	180	GRT3{1}		0	2	-2	0 2 -2
2	180						
J02	F-	SIFI= 1.02	SIFO= 1.02				
		Gravity{1}		0	0	0	0 0 0
0	270	Hydrotest{1}		82	29	29	0 82 29
72	270	Thermal 1{1}		0	0	0	0 0 0
0	270	Thermal 2{1}		0	0	0	0 0 0
0	270	Thermal 3{1}		0	0	0	0 0 0
0	270	GRT1{1}		0	0	0	0 0 0
0	270	GRT2{1}		0	0	0	0 0 0
0	270	GRT3{1}		0	0	0	0 0 0
0	270						
J02	F+	SIFI= 1.00	SIFO= 1.00				
		Gravity{1}		0	0	0	0 0 0
0	270	Hydrotest{1}		82	29	29	0 82 29
72	270	Thermal 1{1}		0	0	0	0 0 0
0	270						

□

CIRCUITOPROVABARRE

GENERAL PIPE STRESS REPORT

(Stress in N/mm2)

Point Total name Stress	Load combination Loc	Hoop Stress	Longitudinal Max Min	Shear Stress	Principal Max Min
0	Thermal 2{1} 270	0	0 0	0	0 0
0	Thermal 3{1} 270	0	0 0	0	0 0
0	GRT1{1} 270	0	0 0	0	0 0
0	GRT2{1} 270	0	0 0	0	0 0
0	GRT3{1} 270	0	0 0	0	0 0
J03 0	SIFI= 1.00 SIFO= 1.00 Gravity{1} 270	0	0 0	0	0 0
72	Hydrotest{1} 270	82	29 29	0	82 29
0	Thermal 1{1} 90	0	0 0	0	0 0
0	Thermal 2{1} 270	0	0 0	0	0 0
0	Thermal 3{1} 270	0	0 0	0	0 0
0	GRT1{1} 270	0	0 0	0	0 0
0	GRT2{1} 270	0	0 0	0	0 0
0	GRT3{1} 270	0	0 0	0	0 0
J04 0	SIFI= 1.00 SIFO= 1.00 Gravity{1} 270	0	0 0	0	0 0
72	Hydrotest{1} 270	82	29 29	0	82 29
0	Thermal 1{1} 90	0	0 0	0	0 0
0	Thermal 2{1} 270	0	0 0	0	0 0
0	Thermal 3{1} 270	0	0 0	0	0 0
0	GRT1{1} 270	0	0 0	0	0 0
0	GRT2{1} 270	0	0 0	0	0 0
0	GRT3{1} 270	0	0 0	0	0 0

*** Segment J end ***

*** Segment K begin ***

circuitoprovabarre.txt

Point	Load	Ma	Mb	Mc	S.I.F	Eq. no.	Load type
D03	SIFI= 2.10 SIFO= 2.10						
0	Gravity{1}	0	0	0	0	0	0
54	Hydrotest{1}	61	19	19	0	61	19
0	Thermal 1{1}	0	0	0	0	0	0
0	Thermal 2{1}	0	0	0	0	0	0
0	Thermal 3{1}	0	0	0	0	0	0
0	GRT1{1}	0	0	0	0	0	0
0	GRT2{1}	0	0	0	0	0	0
0	GRT3{1}	0	0	0	0	0	0
K01	SIFI= 1.00 SIFO= 1.00						
0	Gravity{1}	0	0	0	0	0	0
54	Hydrotest{1}	61	19	19	0	61	19
0	Thermal 1{1}	0	0	0	0	0	0
0	Thermal 2{1}	0	0	0	0	0	0
0	Thermal 3{1}	0	0	0	0	0	0
0	GRT1{1}	0	0	0	0	0	0
0	GRT2{1}	0	0	0	0	0	0
0	GRT3{1}	0	0	0	0	0	0

*** Segment K end ***

□

CIRCUITOPROVABARRE

07/30/2010 CIRCUITO PROVA BARRE
BENTLEY

02:16 PM

AutoPIPE Plus 9.2.1 RESULT PAGE 85

EN 13480 (2002) CODE COMPLIANCE

(Moments in N.m) (Stress in N/mm2)

Point Code name	Load Code combination	Ma (Sus.)	Mb (Occ.)	Mc (Exp.)	S.I.F	Eq. no.	Load type
H06	Max P{1}						HOOP
44	121						
	GR + Max P{1}	17			2.00	2-1	SUST
85	121						
	TR:Amb to T1{1}			14	2.00	4-1	DISP
66	247						
	Amb to T1{1}			14	2.00	4-1	DISP
66	247						

circuitoprovabarre.txt

39	Amb to T2{1}			8	2.00	4-1	DISP
	245						
4	Amb to T3{1}			1	2.00	4-1	DISP
	229						
96	Hydrotest{1}	0	17		2.00	3-1	OCC
	219						
	Sus.+T1{1}				2.00	5-1	CRUP
102	<NOTE 1>						
	Sus.+T2{1}				2.00	5-1	CRUP
95	<NOTE 1>						
	Sus.+T3{1}				2.00	5-1	CRUP
86	<NOTE 1>						
B02	Max P{1}						HOOP
41	86						
	GR + Max P{1}	60			2.00	2-1	SUST
75	86						
	TR:Amb to T2{1}			47	2.00	4-1	DISP
57	197						
	Amb to T1{1}			40	2.00	4-1	DISP
49	197						
	Amb to T2{1}			47	2.00	4-1	DISP
57	197						
	Amb to T3{1}			8	2.00	4-1	DISP
10	223						
	Hydrotest{1}	0	60		2.00	3-1	OCC
86	219						
	Sus.+T1{1}				2.00	5-1	CRUP
87	<NOTE 1>						
	Sus.+T2{1}				2.00	5-1	CRUP
89	<NOTE 1>						
	Sus.+T3{1}				2.00	5-1	CRUP
78	<NOTE 1>						
A07	+ Max P{1}						HOOP
59	88						
	GR + Max P{1}	379			2.10	2-1	SUST
67	88						
	TR:Amb to T1{1}			91	2.10	4-1	DISP
12	200						
	Amb to T1{1}			91	2.10	4-1	DISP
12	200						
	Amb to T2{1}			38	2.10	4-1	DISP
5	200						
	Amb to T3{1}			7	2.10	4-1	DISP
1	229						
	Hydrotest{1}	0	379		2.10	3-1	OCC
82	219						
	Sus.+T1{1}				2.10	5-1	CRUP
70	<NOTE 1>						
	Sus.+T2{1}				2.10	5-1	CRUP
68	<NOTE 1>						
	Sus.+T3{1}				2.10	5-1	CRUP
67	<NOTE 1>						
A07	- Max P{1}						HOOP
59	88						
	GR + Max P{1}	379			2.10	2-1	SUST
67	88						
	TR:Amb to T1{1}			91	2.10	4-1	DISP
12	200						
	Amb to T1{1}			91	2.10	4-1	DISP
12	200						
	Amb to T2{1}			38	2.10	4-1	DISP
5	200						
	Amb to T3{1}			7	2.10	4-1	DISP
1	229						
	Hydrotest{1}	0	379		2.10	3-1	OCC

circuitoprovabarre.txt

82 219
 Sus.+T1{1} 2.10 5-1 CRUP
 70 <NOTE 1>
 Sus.+T2{1} 2.10 5-1 CRUP
 68 <NOTE 1>
 Sus.+T3{1} 2.10 5-1 CRUP
 67 <NOTE 1>

□

 CIRCUITOPROVABARRE

07/30/2010 CIRCUITO PROVA BARRE
 BENTLEY

02:16 PM

AutoPIPE Plus 9.2.1 RESULT PAGE 86

 EN 13480 (2002) CODE COMPLIANCE

(Moments in N.m) (Stress in N/mm2)

Point Code name Stress	Load Code combination Allow.	Ma (Sus.)	Mb (Occ.)	Mc (Exp.)	S.I.F	Eq. no.	Load type
H09 64	Max P{1} 121						HOOP
65	GR + Max P{1} 121	88			1.00	2-1	SUST
5	TR:Amb to T1{1} 247			13	1.00	4-1	DISP
5	Amb to T1{1} 247			13	1.00	4-1	DISP
3	Amb to T2{1} 245			9	1.00	4-1	DISP
1	Amb to T3{1} 229			2	1.00	4-1	DISP
81	Hydrotest{1} 219	0	88		1.00	3-1	OCC
67 <NOTE 1>	Sus.+T1{1}				1.00	5-1	CRUP
66 <NOTE 1>	Sus.+T2{1}				1.00	5-1	CRUP
65 <NOTE 1>	Sus.+T3{1}				1.00	5-1	CRUP
D01 64	+ Max P{1} 88						HOOP
64	GR + Max P{1} 88	86			1.00	2-1	SUST
43	TR:Amb to T2{1} 200			114	1.00	4-1	DISP
27	Amb to T1{1} 247			70	1.00	4-1	DISP
43	Amb to T2{1} 200			114	1.00	4-1	DISP
13	Amb to T3{1} 229			35	1.00	4-1	DISP
81	Hydrotest{1} 219	0	88		1.00	3-1	OCC
73 <NOTE 1>	Sus.+T1{1}				1.00	5-1	CRUP
	Sus.+T2{1}				1.00	5-1	CRUP

circuitoprovabarre.txt

79	<NOTE 1>								
	Sus.+T3{1}					1.00	5-1	CRUP	
69	<NOTE 1>								
	D01 - Max P{1}							HOOP	
64	88								
	GR + Max P{1}	86				1.00	2-1	SUST	
64	88								
	TR:Amb to T2{1}				114	1.00	4-1	DISP	
43	200								
	Amb to T1{1}				70	1.00	4-1	DISP	
27	200								
	Amb to T2{1}				114	1.00	4-1	DISP	
43	200								
	Amb to T3{1}				35	1.00	4-1	DISP	
13	229								
	Hydrotest{1}	0	88			1.00	3-1	OCC	
81	219								
	Sus.+T1{1}					1.00	5-1	CRUP	
73	<NOTE 1>								
	Sus.+T2{1}					1.00	5-1	CRUP	
79	<NOTE 1>								
	Sus.+T3{1}					1.00	5-1	CRUP	
69	<NOTE 1>								
	D08 Max P{1}							HOOP	
64	88								
	GR + Max P{1}	81				1.00	2-1	SUST	
63	88								
	TR:Amb to T2{1}				103	1.00	4-1	DISP	
39	200								
	Amb to T1{1}				64	1.00	4-1	DISP	
24	247								
	Amb to T2{1}				103	1.00	4-1	DISP	
39	200								
	Amb to T3{1}				32	1.00	4-1	DISP	
12	229								
	Hydrotest{1}	0	82			1.00	3-1	OCC	
79	219								
	Sus.+T1{1}					1.00	5-1	CRUP	
71	<NOTE 1>								
	Sus.+T2{1}					1.00	5-1	CRUP	
76	<NOTE 1>								
	Sus.+T3{1}					1.00	5-1	CRUP	
67	<NOTE 1>								

□

CIRCUITOPROVABARRE

07/30/2010 CIRCUITO PROVA BARRE
BENTLEY

02:16 PM

AutoPIPE Plus 9.2.1 RESULT PAGE 87

EN 13480 (2002) CODE COMPLIANCE

(Moments in N.m) (Stress in N/mm2)

Point Code name Stress	Load Code combination Allow.	Ma (Sus.)	Mb (Occ.)	Mc (Exp.)	S.I.F	Eq. no.	Load type
-----	-----	-----	-----	-----	-----	-----	-----

circuitoprovabarre.txt

A10	Max P{1}				HOOP
64	88				
	GR + Max P{1}	91		2.10	2-1 SUST
57	88				
	TR:Amb to T2{1}		125	2.10	4-1 DISP
46	200				
	Amb to T1{1}		77	2.10	4-1 DISP
28	200				
	Amb to T2{1}		125	2.10	4-1 DISP
46	200				
	Amb to T3{1}		39	2.10	4-1 DISP
14	229				
	Hydrotest{1}	0	93	2.10	3-1 OCC
73	219				
	Sus.+T1{1}			2.10	5-1 CRUP
64	<NOTE 1>				
	Sus.+T2{1}			2.10	5-1 CRUP
68	<NOTE 1>				
	Sus.+T3{1}			2.10	5-1 CRUP
60	<NOTE 1>				
A01	- Max P{1}				HOOP
59	88				
	GR + Max P{1}	263		2.10	2-1 SUST
56	88				
	TR:T2 to T3{1}		51	2.10	4-1 DISP
7	200				
	Amb to T1{1}		51	2.10	4-1 DISP
7	200				
	Amb to T2{1}		46	2.10	4-1 DISP
6	200				
	Amb to T3{1}		27	2.10	4-1 DISP
4	229				
	Hydrotest{1}	0	264	2.10	3-1 OCC
71	219				
	Sus.+T1{1}			2.10	5-1 CRUP
57	<NOTE 1>				
	Sus.+T2{1}			2.10	5-1 CRUP
57	<NOTE 1>				
	Sus.+T3{1}			2.10	5-1 CRUP
56	<NOTE 1>				
A26	+ Max P{1}				HOOP
59	88				
	GR + Max P{1}	388		1.00	2-1 SUST
54	88				
	TR:Amb to T1{1}		93	1.00	4-1 DISP
6	200				
	Amb to T1{1}		93	1.00	4-1 DISP
6	200				
	Amb to T2{1}		40	1.00	4-1 DISP
2	200				
	Amb to T3{1}		6	1.00	4-1 DISP
0	229				
	Hydrotest{1}	0	388	1.00	3-1 OCC
69	219				
	Sus.+T1{1}			1.00	5-1 CRUP
56	<NOTE 1>				
	Sus.+T2{1}			1.00	5-1 CRUP
55	<NOTE 1>				
	Sus.+T3{1}			1.00	5-1 CRUP
54	<NOTE 1>				
A26	- Max P{1}				HOOP
59	88				
	GR + Max P{1}	388		1.00	2-1 SUST
54	88				
	TR:Amb to T1{1}		93	1.00	4-1 DISP

circuitoprovabarre.txt

6	200	Amb to T1{1}	93	1.00	4-1	DISP
6	200	Amb to T2{1}	40	1.00	4-1	DISP
2	200	Amb to T3{1}	6	1.00	4-1	DISP
0	229	Hydrotest{1}	0	388	1.00	3-1 OCC
69	219	Sus.+T1{1}		1.00	5-1	CRUP
56	<NOTE 1>	Sus.+T2{1}		1.00	5-1	CRUP
55	<NOTE 1>	Sus.+T3{1}		1.00	5-1	CRUP
54	<NOTE 1>					

□

CIRCUITOPROVABARRE

07/30/2010 CIRCUITO PROVA BARRE
BENTLEY

02:16 PM

AutoPIPE Plus 9.2.1 RESULT PAGE 88

EN 13480 (2002) CODE COMPLIANCE

(Moments in N.m) (Stress in N/mm2)

Point Code	Load Code	Ma (Sus.)	Mb (Occ.)	Mc (Exp.)	S.I.F	Eq. no.	Load type
A10	Max P{1}						HOOP
59	88						
53	GR + Max P{1}	240			2.10	2-1	SUST
11	TR:Amb to T2{1}			87	2.10	4-1	DISP
11	200			87	2.10	4-1	DISP
11	Amb to T1{1}			87	2.10	4-1	DISP
5	Amb to T2{1}			41	2.10	4-1	DISP
5	200			9	2.10	4-1	DISP
1	Amb to T3{1}			9	2.10	4-1	DISP
1	229						
68	Hydrotest{1}	0	240		2.10	3-1	OCC
68	219						
68	Sus.+T1{1}				2.10	5-1	CRUP
56	<NOTE 1>				2.10	5-1	CRUP
56	<NOTE 1>				2.10	5-1	CRUP
55	<NOTE 1>				2.10	5-1	CRUP
55	<NOTE 1>				2.10	5-1	CRUP
54	<NOTE 1>				2.10	5-1	CRUP
A05	Max P{1}						HOOP
59	88						
59	GR + Max P{1}	365			1.00	2-1	SUST
53	88						
53	TR:Amb to T1{1}			88	1.00	4-1	DISP
5	200			88	1.00	4-1	DISP
5	Amb to T1{1}			88	1.00	4-1	DISP
5	200			37	1.00	4-1	DISP
5	Amb to T2{1}			37	1.00	4-1	DISP

circuitoprovabarre.txt

2	200						
	Amb to T3{1}			7	1.00	4-1	DISP
0	229						
	Hydrotest{1}	0	366		1.00	3-1	OCC
67	219						
	Sus.+T1{1}				1.00	5-1	CRUP
54	<NOTE 1>						
	Sus.+T2{1}				1.00	5-1	CRUP
53	<NOTE 1>						
	Sus.+T3{1}				1.00	5-1	CRUP
53	<NOTE 1>						
	B01 + Max P{1}						HOOP
41	86						
	GR + Max P{1}	59			1.00	2-1	SUST
57	86						
	TR:Amb to T2{1}			52	1.00	4-1	DISP
32	197						
	Amb to T1{1}			45	1.00	4-1	DISP
27	197						
	Amb to T2{1}			52	1.00	4-1	DISP
32	197						
	Amb to T3{1}			9	1.00	4-1	DISP
6	223						
	Hydrotest{1}	0	60		1.00	3-1	OCC
67	219						
	Sus.+T1{1}				1.00	5-1	CRUP
66	<NOTE 1>						
	Sus.+T2{1}				1.00	5-1	CRUP
67	<NOTE 1>						
	Sus.+T3{1}				1.00	5-1	CRUP
58	<NOTE 1>						
	B01 - Max P{1}						HOOP
41	86						
	GR + Max P{1}	59			1.00	2-1	SUST
57	86						
	TR:Amb to T2{1}			52	1.00	4-1	DISP
32	197						
	Amb to T1{1}			45	1.00	4-1	DISP
27	197						
	Amb to T2{1}			52	1.00	4-1	DISP
32	197						
	Amb to T3{1}			9	1.00	4-1	DISP
6	223						
	Hydrotest{1}	0	60		1.00	3-1	OCC
67	219						
	Sus.+T1{1}				1.00	5-1	CRUP
66	<NOTE 1>						
	Sus.+T2{1}				1.00	5-1	CRUP
67	<NOTE 1>						
	Sus.+T3{1}				1.00	5-1	CRUP
58	<NOTE 1>						

□

 CIRCUITOPROVABARRE

07/30/2010 CIRCUITO PROVA BARRE
 BENTLEY

02:16 PM

AutoPIPE Plus 9.2.1 RESULT PAGE 89

 EN 13480 (2002) CODE COMPLIANCE

circuitoprovabarre.txt
(Moments in N.m) (Stress in N/mm2)

Point Code name Stress	Load Code combination Allow.	Ma (Sus.)	Mb (Occ.)	Mc (Exp.)	S.I.F	Eq. Load no. type
B06 67	Max P{1} 86					HOOP
33	GR + Max P{1} 86	0			2.00	2-1 SUST
0	TR:Amb to T2{1}			0	2.00	4-1 DISP
0	Amb to T1{1}			0	2.00	4-1 DISP
0	Amb to T2{1}			0	2.00	4-1 DISP
0	Amb to T3{1}			0	2.00	4-1 DISP
50	223 Hydrotest{1}	0	0		2.00	3-1 OCC
33	219 Sus.+T1{1}				2.00	5-1 CRUP
33	<NOTE 1> Sus.+T2{1}				2.00	5-1 CRUP
33	<NOTE 1> Sus.+T3{1}				2.00	5-1 CRUP
33	<NOTE 1>					
B10 67	Max P{1} 86					HOOP
33	GR + Max P{1} 86	0			1.00	2-1 SUST
0	TR:Amb to T1{1}			0	1.00	4-1 DISP
0	Amb to T1{1}			0	1.00	4-1 DISP
0	Amb to T2{1}			0	1.00	4-1 DISP
0	Amb to T3{1}			0	1.00	4-1 DISP
50	223 Hydrotest{1}	0	0		1.00	3-1 OCC
33	219 Sus.+T1{1}				1.00	5-1 CRUP
33	<NOTE 1> Sus.+T2{1}				1.00	5-1 CRUP
33	<NOTE 1> Sus.+T3{1}				1.00	5-1 CRUP
33	<NOTE 1>					
B05 67	+ Max P{1} 86					HOOP
33	GR + Max P{1} 86	0			2.10	2-1 SUST
0	TR:Amb to T1{1}			0	2.10	4-1 DISP
0	Amb to T1{1}			0	2.10	4-1 DISP
0	Amb to T2{1}			0	2.10	4-1 DISP
0	Amb to T3{1}			0	2.10	4-1 DISP
50	223 Hydrotest{1}	0	0		2.10	3-1 OCC
33	219 Sus.+T1{1}				2.10	5-1 CRUP
33	<NOTE 1> Sus.+T2{1}				2.10	5-1 CRUP
33	<NOTE 1>					

circuitoprovabarre.txt

33	<NOTE 1>	Sus.+T3{1}			2.10	5-1	CRUP
B05	-	Max P{1}					HOOP
67		86					
37		GR + Max P{1}	68		2.10	2-1	SUST
0		86					
0		TR:Amb to T1{1}			0 2.10	4-1	DISP
0		197					
0		Amb to T1{1}			0 2.10	4-1	DISP
0		197					
0		Amb to T2{1}			0 2.10	4-1	DISP
0		197					
0		Amb to T3{1}			0 2.10	4-1	DISP
0		223					
54		Hydrotest{1}	0 68		2.10	3-1	OCC
37	<NOTE 1>	Sus.+T1{1}			2.10	5-1	CRUP
37	<NOTE 1>	Sus.+T2{1}			2.10	5-1	CRUP
37	<NOTE 1>	Sus.+T3{1}			2.10	5-1	CRUP

□

 CIRCUITOPROVABARRE

07/30/2010 CIRCUITO PROVA BARRE
 BENTLEY

02:16 PM

AutoPIPE Plus 9.2.1 RESULT PAGE 90

 EN 13480 (2002) CODE COMPLIANCE

(Moments in N.m) (Stress in N/mm2)

Point Code	Load Code	Ma (Sus.)	Mb (Occ.)	Mc (Exp.)	S.I.F	Eq. no.	Load type
name	combination						
Stress	Allow.						
B09	+ Max P{1}						HOOP
67	86						
36	GR + Max P{1}	68			1.00	2-1	SUST
0	86						
0	TR:T2 to T3{1}				0 1.00	4-1	DISP
0	197						
0	Amb to T1{1}				0 1.00	4-1	DISP
0	197						
0	Amb to T2{1}				0 1.00	4-1	DISP
0	197						
0	Amb to T3{1}				0 1.00	4-1	DISP
0	223						
52	Hydrotest{1}	0 68			1.00	3-1	OCC
36	<NOTE 1>				1.00	5-1	CRUP
36	<NOTE 1>				1.00	5-1	CRUP
36	<NOTE 1>				1.00	5-1	CRUP
B09	- Max P{1}						HOOP

circuitoprovabarre.txt

67	86							
	GR + Max P{1}	68		1.00	2-1	SUST		
36	86							
	TR:T2 to T3{1}			0	1.00	4-1	DISP	
0	197							
	Amb to T1{1}			0	1.00	4-1	DISP	
0	197							
	Amb to T2{1}			0	1.00	4-1	DISP	
0	197							
	Amb to T3{1}			0	1.00	4-1	DISP	
0	223							
	Hydrotest{1}	0	68		1.00	3-1	OCC	
52	219							
	Sus.+T1{1}				1.00	5-1	CRUP	
36	<NOTE 1>							
	Sus.+T2{1}				1.00	5-1	CRUP	
36	<NOTE 1>							
	Sus.+T3{1}				1.00	5-1	CRUP	
36	<NOTE 1>							
B04	Max P{1}						HOOP	
67	86							
	GR + Max P{1}	61			2.00	2-1	SUST	
36	86							
	TR:Amb to T2{1}			37	2.00	4-1	DISP	
3	197							
	Amb to T1{1}			32	2.00	4-1	DISP	
2	197							
	Amb to T2{1}			37	2.00	4-1	DISP	
3	197							
	Amb to T3{1}			7	2.00	4-1	DISP	
0	223							
	Hydrotest{1}	0	62		2.00	3-1	OCC	
53	219							
	Sus.+T1{1}				2.00	5-1	CRUP	
37	<NOTE 1>							
	Sus.+T2{1}				2.00	5-1	CRUP	
37	<NOTE 1>							
	Sus.+T3{1}				2.00	5-1	CRUP	
37	<NOTE 1>							
A01	+ Max P{1}						HOOP	
59	88							
	GR + Max P{1}	208			2.10	2-1	SUST	
50	88							
	TR:T2 to T3{1}			30	2.10	4-1	DISP	
4	200							
	Amb to T1{1}			1	2.10	4-1	DISP	
0	200							
	Amb to T2{1}			13	2.10	4-1	DISP	
2	200							
	Amb to T3{1}			16	2.10	4-1	DISP	
2	229							
	Hydrotest{1}	0	209		2.10	3-1	OCC	
65	219							
	Sus.+T1{1}				2.10	5-1	CRUP	
50	<NOTE 1>							
	Sus.+T2{1}				2.10	5-1	CRUP	
51	<NOTE 1>							
	Sus.+T3{1}				2.10	5-1	CRUP	
51	<NOTE 1>							

□

 CIRCUITOPROVABARRE

07/30/2010 CIRCUITO PROVA BARRE

EN 13480 (2002) CODE COMPLIANCE

(Moments in N.m) (Stress in N/mm2)

Point Code name	Load Code combination	Ma (Sus.)	Mb (Occ.)	Mc (Exp.)	S.I.F	Eq. Load no.	type
B05 64	Max P{1}						HOOP
	86						
49	GR + Max P{1}	68			2.10	2-1	SUST
	86						
0	TR:Amb to T1{1}			0	2.10	4-1	DISP
	197						
0	Amb to T1{1}			0	2.10	4-1	DISP
	197						
0	Amb to T2{1}			0	2.10	4-1	DISP
	197						
0	Amb to T3{1}			0	2.10	4-1	DISP
	223						
65	Hydrotest{1}	0	68		2.10	3-1	OCC
	219						
49	Sus.+T1{1}				2.10	5-1	CRUP
	<NOTE 1>						
49	Sus.+T2{1}				2.10	5-1	CRUP
	<NOTE 1>						
49	Sus.+T3{1}				2.10	5-1	CRUP
	<NOTE 1>						
A03 F+	Max P{1}						HOOP
59	88						
50	GR + Max P{1}	202			2.10	2-1	SUST
	88						
7	TR:Amb to T1{1}			51	2.10	4-1	DISP
	200						
7	Amb to T1{1}			51	2.10	4-1	DISP
	200						
6	Amb to T2{1}			48	2.10	4-1	DISP
	200						
4	Amb to T3{1}			27	2.10	4-1	DISP
	229						
64	Hydrotest{1}	0	202		2.10	3-1	OCC
	219						
51	Sus.+T1{1}				2.10	5-1	CRUP
	<NOTE 1>						
51	Sus.+T2{1}				2.10	5-1	CRUP
	<NOTE 1>						
50	Sus.+T3{1}				2.10	5-1	CRUP
	<NOTE 1>						
A03 F-	Max P{1}						HOOP
59	88						
50	GR + Max P{1}	202			2.10	2-1	SUST
	88						
7	TR:Amb to T1{1}			51	2.10	4-1	DISP
	200						
7	Amb to T1{1}			51	2.10	4-1	DISP
	200						
6	Amb to T2{1}			48	2.10	4-1	DISP
	200						

circuitoprovabarre.txt

4	Amb to T3{1}			27	2.10	4-1	DISP
64	229 Hydrotest{1}	0	202		2.10	3-1	OCC
51	219 Sus.+T1{1}				2.10	5-1	CRUP
51	<NOTE 1> Sus.+T2{1}				2.10	5-1	CRUP
50	<NOTE 1> Sus.+T3{1}				2.10	5-1	CRUP
59	A25 + Max P{1}						HOOP
49	88 GR + Max P{1}	315			1.00	2-1	SUST
3	88 TR:Amb to T1{1}			49	1.00	4-1	DISP
3	200 Amb to T1{1}			49	1.00	4-1	DISP
3	200 Amb to T2{1}			45	1.00	4-1	DISP
2	200 Amb to T3{1}			27	1.00	4-1	DISP
64	229 Hydrotest{1}	0	316		1.00	3-1	OCC
50	219 Sus.+T1{1}				1.00	5-1	CRUP
50	<NOTE 1> Sus.+T2{1}				1.00	5-1	CRUP
50	<NOTE 1> Sus.+T3{1}				1.00	5-1	CRUP

□

CIRCUITOPROVABARRE

07/30/2010 CIRCUITO PROVA BARRE
BENTLEY

02:16 PM

AutoPIPE Plus 9.2.1 RESULT PAGE 92

EN 13480 (2002) CODE COMPLIANCE

(Moments in N.m) (Stress in N/mm2)

Point Code name	Load Code combination	Ma (Sus.)	Mb (Occ.)	Mc (Exp.)	S.I.F	Eq. no.	Load type
A25	- Max P{1}						HOOP
59	88						
49	GR + Max P{1}	315			1.00	2-1	SUST
3	88						
3	TR:Amb to T1{1}			49	1.00	4-1	DISP
3	200						
3	Amb to T1{1}			49	1.00	4-1	DISP
3	200						
3	Amb to T2{1}			45	1.00	4-1	DISP
2	200						
2	Amb to T3{1}			27	1.00	4-1	DISP
64	229						
64	Hydrotest{1}	0	316		1.00	3-1	OCC

circuitoprovabarre.txt

50	<NOTE 1>	Sus.+T1{1}			1.00	5-1	CRUP
50	<NOTE 1>	Sus.+T2{1}			1.00	5-1	CRUP
50	<NOTE 1>	Sus.+T3{1}			1.00	5-1	CRUP
H03 + Max P{1} HOOP							
44		121					
27		GR + Max P{1}	1		2.10	2-1	SUST
64		121					
64		TR:T1 to T3{1}		13	2.10	4-1	DISP
61		229					
61		Amb to T1{1}		12	2.10	4-1	DISP
27		247					
27		Amb to T2{1}		5	2.10	4-1	DISP
3		245					
3		Amb to T3{1}		1	2.10	4-1	DISP
39		229					
39		Hydrotest{1}	0	1	2.10	3-1	OCC
42	<NOTE 1>	219					
42	<NOTE 1>	Sus.+T1{1}			2.10	5-1	CRUP
34	<NOTE 1>	Sus.+T2{1}			2.10	5-1	CRUP
28	<NOTE 1>	Sus.+T3{1}			2.10	5-1	CRUP
H03 - Max P{1} HOOP							
44		121					
27		GR + Max P{1}	1		2.10	2-1	SUST
64		121					
64		TR:T1 to T3{1}		13	2.10	4-1	DISP
61		229					
61		Amb to T1{1}		12	2.10	4-1	DISP
27		247					
27		Amb to T2{1}		5	2.10	4-1	DISP
3		245					
3		Amb to T3{1}		1	2.10	4-1	DISP
39		229					
39		Hydrotest{1}	0	1	2.10	3-1	OCC
42	<NOTE 1>	219					
42	<NOTE 1>	Sus.+T1{1}			2.10	5-1	CRUP
34	<NOTE 1>	Sus.+T2{1}			2.10	5-1	CRUP
28	<NOTE 1>	Sus.+T3{1}			2.10	5-1	CRUP
J04 Max P{1} HOOP							
64		86					
32		GR + Max P{1}	0		1.00	2-1	SUST
0		86					
0		TR:T1 to T2{1}		0	1.00	4-1	DISP
0		197					
0		Amb to T1{1}		0	1.00	4-1	DISP
0		197					
0		Amb to T2{1}		0	1.00	4-1	DISP
0		197					
0		Amb to T3{1}		0	1.00	4-1	DISP
48		223					
48		Hydrotest{1}	0	0	1.00	3-1	OCC
32	<NOTE 1>	219					
32	<NOTE 1>	Sus.+T1{1}			1.00	5-1	CRUP
32	<NOTE 1>	Sus.+T2{1}			1.00	5-1	CRUP
32	<NOTE 1>	Sus.+T3{1}			1.00	5-1	CRUP

32 <NOTE 1>

□

 CIRCUITOPROVABARRE

07/30/2010 CIRCUITO PROVA BARRE
 BENTLEY

02:16 PM

AutoPIPE Plus 9.2.1 RESULT PAGE 93

 EN 13480 (2002) CODE COMPLIANCE

(Moments in N.m) (Stress in N/mm2)

Point Code name Stress	Load Code combination Allow.	Ma (Sus.)	Mb (Occ.)	Mc (Exp.)	S.I.F	Eq. no.	Load type
J03 64	Max P{1} 86						HOOP
32	GR + Max P{1} 86	0			1.00	2-1	SUST
0	TR:Amb to T1{1} 197			0	1.00	4-1	DISP
0	Amb to T1{1} 197			0	1.00	4-1	DISP
0	Amb to T2{1} 197			0	1.00	4-1	DISP
0	Amb to T3{1} 223			0	1.00	4-1	DISP
48	Hydrotest{1} 219	0	0		1.00	3-1	OCC
32 <NOTE 1>	Sus.+T1{1}				1.00	5-1	CRUP
32 <NOTE 1>	Sus.+T2{1}				1.00	5-1	CRUP
32 <NOTE 1>	Sus.+T3{1}				1.00	5-1	CRUP
J02 F+ 64	Max P{1} 86						HOOP
32	GR + Max P{1} 86	0			1.00	2-1	SUST
0	TR:T2 to T3{1} 197			0	1.00	4-1	DISP
0	Amb to T1{1} 197			0	1.00	4-1	DISP
0	Amb to T2{1} 197			0	1.00	4-1	DISP
0	Amb to T3{1} 223			0	1.00	4-1	DISP
48	Hydrotest{1} 219	0	0		1.00	3-1	OCC
32 <NOTE 1>	Sus.+T1{1}				1.00	5-1	CRUP
32 <NOTE 1>	Sus.+T2{1}				1.00	5-1	CRUP
32 <NOTE 1>	Sus.+T3{1}				1.00	5-1	CRUP
J02 F- 64	Max P{1} 86						HOOP

circuitoprovabarre.txt

32	GR + Max P{1}	0		1.02	2-1	SUST
0	86					
0	TR:T2 to T3{1}			0	1.02	4-1 DISP
0	197					
0	Amb to T1{1}			0	1.02	4-1 DISP
0	197					
0	Amb to T2{1}			0	1.02	4-1 DISP
0	197					
0	Amb to T3{1}			0	1.02	4-1 DISP
0	223					
48	Hydrotest{1}	0	0	1.02	3-1	OCC
0	219					
32	Sus.+T1{1}			1.02	5-1	CRUP
32	<NOTE 1>					
32	Sus.+T2{1}			1.02	5-1	CRUP
32	<NOTE 1>					
32	Sus.+T3{1}			1.02	5-1	CRUP
32	<NOTE 1>					
64	J02 N+ Max P{1}					HOOP
33	86	5		1.02	2-1	SUST
0	GR + Max P{1}					
0	86					
0	TR:Amb to T1{1}			0	1.02	4-1 DISP
0	197					
0	Amb to T1{1}			0	1.02	4-1 DISP
0	197					
0	Amb to T2{1}			0	1.02	4-1 DISP
0	197					
0	Amb to T3{1}			0	1.02	4-1 DISP
0	223					
49	Hydrotest{1}	0	5	1.02	3-1	OCC
0	219					
33	Sus.+T1{1}			1.02	5-1	CRUP
33	<NOTE 1>					
33	Sus.+T2{1}			1.02	5-1	CRUP
33	<NOTE 1>					
33	Sus.+T3{1}			1.02	5-1	CRUP
33	<NOTE 1>					

□

CIRCUITOPROVABARRE

07/30/2010 CIRCUITO PROVA BARRE
BENTLEY

02:16 PM

AutoPIPE Plus 9.2.1 RESULT PAGE 94

EN 13480 (2002) CODE COMPLIANCE

(Moments in N.m) (Stress in N/mm2)

Point Code name	Load Code combination	Ma (Sus.)	Mb (Occ.)	Mc (Exp.)	S.I.F	Eq. no.	Load type
64	J02 N- Max P{1}						HOOP
33	86	5			1.00	2-1	SUST
0	GR + Max P{1}						
0	86						
0	TR:Amb to T1{1}			0	1.00	4-1	DISP
0	197						

circuitoprovabarre.txt

0	Amb to T1{1}		0	1.00	4-1	DISP
197						
0	Amb to T2{1}		0	1.00	4-1	DISP
197						
0	Amb to T3{1}		0	1.00	4-1	DISP
223						
49	Hydrotest{1}	0	5	1.00	3-1	OCC
219						
	Sus.+T1{1}			1.00	5-1	CRUP
33	<NOTE 1>					
	Sus.+T2{1}			1.00	5-1	CRUP
33	<NOTE 1>					
	Sus.+T3{1}			1.00	5-1	CRUP
33	<NOTE 1>					
J01	Max P{1}					HOOP
64	86					
	GR + Max P{1}	5		1.00	2-1	SUST
34	86					
	TR:Amb to T1{1}			0	1.00	4-1 DISP
0	197					
	Amb to T1{1}			0	1.00	4-1 DISP
0	197					
	Amb to T2{1}			0	1.00	4-1 DISP
0	197					
	Amb to T3{1}			0	1.00	4-1 DISP
0	223					
	Hydrotest{1}	0	5	1.00	3-1	OCC
49	219					
	Sus.+T1{1}			1.00	5-1	CRUP
34	<NOTE 1>					
	Sus.+T2{1}			1.00	5-1	CRUP
34	<NOTE 1>					
	Sus.+T3{1}			1.00	5-1	CRUP
34	<NOTE 1>					
D07	Max P{1}					HOOP
64	88					
	GR + Max P{1}	6		1.00	2-1	SUST
34	88					
	TR:Amb to T2{1}			46	1.00	4-1 DISP
17	200					
	Amb to T1{1}			26	1.00	4-1 DISP
10	247					
	Amb to T2{1}			46	1.00	4-1 DISP
17	200					
	Amb to T3{1}			15	1.00	4-1 DISP
6	229					
	Hydrotest{1}	0	6	1.00	3-1	OCC
50	219					
	Sus.+T1{1}			1.00	5-1	CRUP
37	<NOTE 1>					
	Sus.+T2{1}			1.00	5-1	CRUP
40	<NOTE 1>					
	Sus.+T3{1}			1.00	5-1	CRUP
36	<NOTE 1>					
H20	+ Max P{1}					HOOP
64	88					
	GR + Max P{1}	5		1.00	2-1	SUST
34	88					
	TR:Amb to T2{1}			44	1.00	4-1 DISP
17	200					
	Amb to T1{1}			25	1.00	4-1 DISP
9	247					
	Amb to T2{1}			44	1.00	4-1 DISP
17	200					
	Amb to T3{1}			15	1.00	4-1 DISP

circuitoprovabarre.txt

6	229	Hydrotest{1}	0	5	1.00	3-1	OCC
50	219	Sus.+T1{1}			1.00	5-1	CRUP
37	<NOTE 1>	Sus.+T2{1}			1.00	5-1	CRUP
39	<NOTE 1>	Sus.+T3{1}			1.00	5-1	CRUP
36	<NOTE 1>						

□

 CIRCUITOPROVABARRE

07/30/2010 CIRCUITO PROVA BARRE
 BENTLEY

02:16 PM

AutoPIPE Plus 9.2.1 RESULT PAGE 95

EN 13480 (2002) CODE COMPLIANCE

(Moments in N.m) (Stress in N/mm2)

Point Code name Stress	Load Code combination Allow.	Ma (Sus.)	Mb (Occ.)	Mc (Exp.)	S.I.F	Eq. no.	Load type
H20 64	- Max P{1} 88						HOOP
34	GR + Max P{1} 88	5			1.00	2-1	SUST
17	TR:Amb to T2{1} 200			44	1.00	4-1	DISP
9	Amb to T1{1} 247			25	1.00	4-1	DISP
17	Amb to T2{1} 200			44	1.00	4-1	DISP
6	Amb to T3{1} 229			15	1.00	4-1	DISP
50	Hydrotest{1} 219	0	5		1.00	3-1	OCC
37	Sus.+T1{1} <NOTE 1>				1.00	5-1	CRUP
39	Sus.+T2{1} <NOTE 1>				1.00	5-1	CRUP
36	Sus.+T3{1} <NOTE 1>				1.00	5-1	CRUP
H10 64	+ Max P{1} 88						HOOP
41	GR + Max P{1} 88	25			1.00	2-1	SUST
5	TR:Amb to T2{1} 200			13	1.00	4-1	DISP
2	Amb to T1{1} 247			5	1.00	4-1	DISP
5	Amb to T2{1} 200			13	1.00	4-1	DISP
2	Amb to T3{1} 229			7	1.00	4-1	DISP
57	Hydrotest{1} 219	0	24		1.00	3-1	OCC
	Sus.+T1{1}				1.00	5-1	CRUP

circuitoprovabarre.txt

42	<NOTE 1>								
	Sus.+T2{1}					1.00	5-1	CRUP	
43	<NOTE 1>								
	Sus.+T3{1}					1.00	5-1	CRUP	
42	<NOTE 1>								
H10	- Max P{1}								HOOP
64	121								
	GR + Max P{1}		25			1.00	2-1	SUST	
41	121								
	TR:Amb to T2{1}				13	1.00	4-1	DISP	
5	245								
	Amb to T1{1}				5	1.00	4-1	DISP	
2	247								
	Amb to T2{1}				13	1.00	4-1	DISP	
5	245								
	Amb to T3{1}				7	1.00	4-1	DISP	
2	229								
	Hydrotest{1}		0	24		1.00	3-1	OCC	
57	219								
	Sus.+T1{1}					1.00	5-1	CRUP	
42	<NOTE 1>								
	Sus.+T2{1}					1.00	5-1	CRUP	
43	<NOTE 1>								
	Sus.+T3{1}					1.00	5-1	CRUP	
42	<NOTE 1>								
H17	+ Max P{1}								HOOP
64	121								
	GR + Max P{1}		27			1.00	2-1	SUST	
42	121								
	TR:Amb to T2{1}				19	1.00	4-1	DISP	
7	245								
	Amb to T1{1}				9	1.00	4-1	DISP	
3	247								
	Amb to T2{1}				19	1.00	4-1	DISP	
7	245								
	Amb to T3{1}				9	1.00	4-1	DISP	
3	229								
	Hydrotest{1}		0	27		1.00	3-1	OCC	
58	219								
	Sus.+T1{1}					1.00	5-1	CRUP	
43	<NOTE 1>								
	Sus.+T2{1}					1.00	5-1	CRUP	
44	<NOTE 1>								
	Sus.+T3{1}					1.00	5-1	CRUP	
43	<NOTE 1>								

□

 CIRCUITOPROVABARRE

07/30/2010 CIRCUITO PROVA BARRE
 BENTLEY

02:16 PM

AutoPIPE Plus 9.2.1 RESULT PAGE 96

EN 13480 (2002) CODE COMPLIANCE

(Moments in N.m) (Stress in N/mm2)

Point Code	Load Code	Ma	Mb	Mc	S.I.F	Eq. Load no.	type
name	combination	(Sus.)	(Occ.)	(Exp.)			
Stress	Allow.						

circuitoprovabarre.txt

H17	- Max P{1}				HOOP
64	121				
	GR + Max P{1}	27		1.00	2-1 SUST
42	121				
	TR:Amb to T2{1}		19	1.00	4-1 DISP
7	245				
	Amb to T1{1}		9	1.00	4-1 DISP
3	247				
	Amb to T2{1}		19	1.00	4-1 DISP
7	245				
	Amb to T3{1}		9	1.00	4-1 DISP
3	229				
	Hydrotest{1}	0	27	1.00	3-1 OCC
58	219				
	Sus.+T1{1}			1.00	5-1 CRUP
43	<NOTE 1>				
	Sus.+T2{1}			1.00	5-1 CRUP
44	<NOTE 1>				
	Sus.+T3{1}			1.00	5-1 CRUP
43	<NOTE 1>				
H08	Max P{1}				HOOP
64	121				
	GR + Max P{1}	22		1.00	2-1 SUST
40	121				
	TR:Amb to T1{1}		14	1.00	4-1 DISP
5	247				
	Amb to T1{1}		14	1.00	4-1 DISP
5	247				
	Amb to T2{1}		8	1.00	4-1 DISP
3	245				
	Amb to T3{1}		1	1.00	4-1 DISP
0	229				
	Hydrotest{1}	0	21	1.00	3-1 OCC
56	219				
	Sus.+T1{1}			1.00	5-1 CRUP
42	<NOTE 1>				
	Sus.+T2{1}			1.00	5-1 CRUP
41	<NOTE 1>				
	Sus.+T3{1}			1.00	5-1 CRUP
40	<NOTE 1>				
H07	Max P{1}				HOOP
64	121				
	GR + Max P{1}	19		2.00	2-1 SUST
43	121				
	TR:Amb to T1{1}		14	2.00	4-1 DISP
10	247				
	Amb to T1{1}		14	2.00	4-1 DISP
10	247				
	Amb to T2{1}		8	2.00	4-1 DISP
6	245				
	Amb to T3{1}		1	2.00	4-1 DISP
1	229				
	Hydrotest{1}	0	19	2.00	3-1 OCC
58	219				
	Sus.+T1{1}			2.00	5-1 CRUP
45	<NOTE 1>				
	Sus.+T2{1}			2.00	5-1 CRUP
44	<NOTE 1>				
	Sus.+T3{1}			2.00	5-1 CRUP
43	<NOTE 1>				
D07	Max P{1}				HOOP
64	88				
	GR + Max P{1}	6		1.00	2-1 SUST

circuitoprovabarre.txt

34	88							
	TR:Amb to T2{1}			46	1.00	4-1	DISP	
17	200							
	Amb to T1{1}			26	1.00	4-1	DISP	
10	247							
	Amb to T2{1}			46	1.00	4-1	DISP	
17	200							
	Amb to T3{1}			15	1.00	4-1	DISP	
6	229							
	Hydrotest{1}	0	6		1.00	3-1	OCC	
50	219							
	Sus.+T1{1}				1.00	5-1	CRUP	
37	<NOTE 1>							
	Sus.+T2{1}				1.00	5-1	CRUP	
40	<NOTE 1>							
	Sus.+T3{1}				1.00	5-1	CRUP	
36	<NOTE 1>							

□

 CIRCUITOPROVABARRE

07/30/2010 CIRCUITO PROVA BARRE
 BENTLEY

02:16 PM

AutoPIPE Plus 9.2.1 RESULT PAGE 97

 EN 13480 (2002) CODE COMPLIANCE

(Moments in N.m) (Stress in N/mm2)

Point Code	Load Code combination	Ma (Sus.)	Mb (Occ.)	Mc (Exp.)	S.I.F	Eq. no.	Load type
Stress	Allow.						
D06	Max P{1}						HOOP
64	88						
	GR + Max P{1}	6			1.00	2-1	SUST
34	88						
	TR:Amb to T2{1}			47	1.00	4-1	DISP
18	200						
	Amb to T1{1}			26	1.00	4-1	DISP
10	247						
	Amb to T2{1}			47	1.00	4-1	DISP
18	200						
	Amb to T3{1}			16	1.00	4-1	DISP
6	229						
	Hydrotest{1}	0	6		1.00	3-1	OCC
50	219						
	Sus.+T1{1}				1.00	5-1	CRUP
37	<NOTE 1>						
	Sus.+T2{1}				1.00	5-1	CRUP
40	<NOTE 1>						
	Sus.+T3{1}				1.00	5-1	CRUP
36	<NOTE 1>						
D05 F+	Max P{1}						HOOP
64	88						
	GR + Max P{1}	6			1.00	2-1	SUST
34	88						
	TR:Amb to T2{1}			47	1.00	4-1	DISP
18	200						
	Amb to T1{1}			26	1.00	4-1	DISP

circuitoprovabarre.txt

10	247								
	Amb to T2{1}			47	1.00	4-1	DISP		
18	200								
	Amb to T3{1}			16	1.00	4-1	DISP		
6	229								
	Hydrotest{1}	0	6		1.00	3-1	OCC		
50	219								
	Sus.+T1{1}				1.00	5-1	CRUP		
37	<NOTE 1>								
	Sus.+T2{1}				1.00	5-1	CRUP		
40	<NOTE 1>								
	Sus.+T3{1}				1.00	5-1	CRUP		
36	<NOTE 1>								
	D05 F- Max P{1}								HOOP
64	88								
	GR + Max P{1}	6			1.02	2-1	SUST		
34	88								
	TR:Amb to T2{1}			47	1.02	4-1	DISP		
18	200								
	Amb to T1{1}			26	1.02	4-1	DISP		
10	247								
	Amb to T2{1}			47	1.02	4-1	DISP		
18	200								
	Amb to T3{1}			16	1.02	4-1	DISP		
6	229								
	Hydrotest{1}	0	6		1.02	3-1	OCC		
50	219								
	Sus.+T1{1}				1.02	5-1	CRUP		
37	<NOTE 1>								
	Sus.+T2{1}				1.02	5-1	CRUP		
40	<NOTE 1>								
	Sus.+T3{1}				1.02	5-1	CRUP		
36	<NOTE 1>								
	D05 M Max P{1}								HOOP
64	88								
	GR + Max P{1}	7			1.02	2-1	SUST		
34	88								
	TR:Amb to T2{1}			45	1.02	4-1	DISP		
18	200								
	Amb to T1{1}			25	1.02	4-1	DISP		
10	247								
	Amb to T2{1}			45	1.02	4-1	DISP		
18	200								
	Amb to T3{1}			15	1.02	4-1	DISP		
6	229								
	Hydrotest{1}	0	7		1.02	3-1	OCC		
50	219								
	Sus.+T1{1}				1.02	5-1	CRUP		
37	<NOTE 1>								
	Sus.+T2{1}				1.02	5-1	CRUP		
40	<NOTE 1>								
	Sus.+T3{1}				1.02	5-1	CRUP		
36	<NOTE 1>								

□

 CIRCUITOPROVABARRE

07/30/2010 CIRCUITO PROVA BARRE
 BENTLEY

02:16 PM

AutoPIPE Plus 9.2.1

RESULT PAGE 98

circuitoprovabarre.txt
 EN 13480 (2002) CODE COMPLIANCE

(Moments in N.m) (Stress in N/mm2)

Point Code	Load Code name	Load combination	Stress Allow.	Ma (Sus.)	Mb (Occ.)	Mc (Exp.)	S.I.F	Eq. no.	Load type
D05 N+	Max P{1}								HOOP
64	88	GR + Max P{1}		9			1.02	2-1	SUST
35	88	TR:Amb to T2{1}				40	1.02	4-1	DISP
15	200	Amb to T1{1}				22	1.02	4-1	DISP
8	247	Amb to T2{1}				40	1.02	4-1	DISP
15	200	Amb to T3{1}				14	1.02	4-1	DISP
5	229	Hydrotest{1}		0	9		1.02	3-1	OCC
51	219	Sus.+T1{1}					1.02	5-1	CRUP
38	<NOTE 1>	Sus.+T2{1}					1.02	5-1	CRUP
40	<NOTE 1>	Sus.+T3{1}					1.02	5-1	CRUP
37	<NOTE 1>								
D05 N-	Max P{1}								HOOP
64	88	GR + Max P{1}		9			1.00	2-1	SUST
35	88	TR:Amb to T2{1}				40	1.00	4-1	DISP
15	200	Amb to T1{1}				22	1.00	4-1	DISP
8	247	Amb to T2{1}				40	1.00	4-1	DISP
15	200	Amb to T3{1}				14	1.00	4-1	DISP
5	229	Hydrotest{1}		0	9		1.00	3-1	OCC
51	219	Sus.+T1{1}					1.00	5-1	CRUP
38	<NOTE 1>	Sus.+T2{1}					1.00	5-1	CRUP
40	<NOTE 1>	Sus.+T3{1}					1.00	5-1	CRUP
37	<NOTE 1>								
D04	Max P{1}								HOOP
64	88	GR + Max P{1}		9			1.00	2-1	SUST
35	88	TR:Amb to T2{1}				40	1.00	4-1	DISP
15	200	Amb to T1{1}				22	1.00	4-1	DISP
8	247	Amb to T2{1}				40	1.00	4-1	DISP
15	200	Amb to T3{1}				14	1.00	4-1	DISP
5	229	Hydrotest{1}		0	9		1.00	3-1	OCC
51	219	Sus.+T1{1}					1.00	5-1	CRUP
38	<NOTE 1>								

circuitoprovabarre.txt

40	<NOTE 1>	Sus.+T2{1}			1.00	5-1	CRUP
37	<NOTE 1>	Sus.+T3{1}			1.00	5-1	CRUP
64	D03	+ Max P{1}					HOOP
40	88	GR + Max P{1}	14		2.10	2-1	SUST
25	88	TR:Amb to T2{1}		31	2.10	4-1	DISP
13	200	Amb to T1{1}		17	2.10	4-1	DISP
25	247	Amb to T2{1}		31	2.10	4-1	DISP
9	200	Amb to T3{1}		11	2.10	4-1	DISP
56	229	Hydrotest{1}	0	13	2.10	3-1	OCC
43	<NOTE 1>	Sus.+T1{1}			2.10	5-1	CRUP
46	<NOTE 1>	Sus.+T2{1}			2.10	5-1	CRUP
42	<NOTE 1>	Sus.+T3{1}			2.10	5-1	CRUP

□

CIRCUITOPROVABARRE

07/30/2010 CIRCUITO PROVA BARRE
BENTLEY

02:16 PM

AutoPIPE Plus 9.2.1 RESULT PAGE 99

EN 13480 (2002) CODE COMPLIANCE

(Moments in N.m) (Stress in N/mm2)

Point Code	Load Code	Ma	Mb	Mc	S.I.F	Eq. Load no.	Load type
name	combination	(Sus.)	(Occ.)	(Exp.)			
Stress	Allow.						
64	D03 - Max P{1}						HOOP
40	88 GR + Max P{1}	14			2.10	2-1	SUST
25	88 TR:Amb to T2{1}			31	2.10	4-1	DISP
13	200 Amb to T1{1}			17	2.10	4-1	DISP
25	247 Amb to T2{1}			31	2.10	4-1	DISP
9	200 Amb to T3{1}			11	2.10	4-1	DISP
56	229 Hydrotest{1}	0	13		2.10	3-1	OCC
43	<NOTE 1> 219 Sus.+T1{1}				2.10	5-1	CRUP
46	<NOTE 1> Sus.+T2{1}				2.10	5-1	CRUP
42	<NOTE 1> Sus.+T3{1}				2.10	5-1	CRUP

circuitoprovabarre.txt

D02	Max P{1}					HOOP
64	88					
	GR + Max P{1}	18		1.00	2-1	SUST
39	88					
	TR:Amb to T2{1}			23	1.00	4-1 DISP
9	200					
	Amb to T1{1}			12	1.00	4-1 DISP
4	247					
	Amb to T2{1}			23	1.00	4-1 DISP
9	200					
	Amb to T3{1}			8	1.00	4-1 DISP
3	229					
	Hydrotest{1}	0	18		1.00	3-1 OCC
54	219					
	Sus.+T1{1}				1.00	5-1 CRUP
40	<NOTE 1>					
	Sus.+T2{1}				1.00	5-1 CRUP
41	<NOTE 1>					
	Sus.+T3{1}				1.00	5-1 CRUP
40	<NOTE 1>					
B08	Max P{1}					HOOP
64	86					
	GR + Max P{1}	0		1.00	2-1	SUST
32	86					
	TR:Amb to T1{1}			0	1.00	4-1 DISP
0	197					
	Amb to T1{1}			0	1.00	4-1 DISP
0	197					
	Amb to T2{1}			0	1.00	4-1 DISP
0	197					
	Amb to T3{1}			0	1.00	4-1 DISP
0	223					
	Hydrotest{1}	0	0		1.00	3-1 OCC
48	219					
	Sus.+T1{1}				1.00	5-1 CRUP
32	<NOTE 1>					
	Sus.+T2{1}				1.00	5-1 CRUP
32	<NOTE 1>					
	Sus.+T3{1}				1.00	5-1 CRUP
32	<NOTE 1>					
B07	Max P{1}					HOOP
64	86					
	GR + Max P{1}	0		2.00	2-1	SUST
32	86					
	TR:Amb to T1{1}			0	2.00	4-1 DISP
0	197					
	Amb to T1{1}			0	2.00	4-1 DISP
0	197					
	Amb to T2{1}			0	2.00	4-1 DISP
0	197					
	Amb to T3{1}			0	2.00	4-1 DISP
0	223					
	Hydrotest{1}	0	0		2.00	3-1 OCC
48	219					
	Sus.+T1{1}				2.00	5-1 CRUP
32	<NOTE 1>					
	Sus.+T2{1}				2.00	5-1 CRUP
32	<NOTE 1>					
	Sus.+T3{1}				2.00	5-1 CRUP
32	<NOTE 1>					

□

 CIRCUITOPROVABARRE

circuitoprovabarre.txt

07/30/2010 CIRCUITO PROVA BARRE
BENTLEY

02:16 PM

AutoPIPE Plus 9.2.1 RESULT PAGE 100

EN 13480 (2002) CODE COMPLIANCE

(Moments in N.m) (Stress in N/mm2)

Point Code name Stress	Load Code combination Allow.	Ma (Sus.)	Mb (Occ.)	Mc (Exp.)	S.I.F	Eq. Load no. type
A01	Max P{1}					HOOP
41	86					
51	GR + Max P{1}	58			2.10	2-1 SUST
	86					
41	TR:Amb to T2{1}			60	2.10	4-1 DISP
	197					
35	Amb to T1{1}			51	2.10	4-1 DISP
	197					
41	Amb to T2{1}			60	2.10	4-1 DISP
	197					
7	Amb to T3{1}			11	2.10	4-1 DISP
	223					
61	Hydrotest{1}	0	59		2.10	3-1 OCC
	219					
59	Sus.+T1{1}				2.10	5-1 CRUP
	<NOTE 1>					
61	Sus.+T2{1}				2.10	5-1 CRUP
	<NOTE 1>					
61	Sus.+T3{1}				2.10	5-1 CRUP
	<NOTE 1>					
52	<NOTE 1>					
A09 F+	Max P{1}					HOOP
59	88					
45	GR + Max P{1}	243			1.00	2-1 SUST
	88					
6	TR:Amb to T1{1}			92	1.00	4-1 DISP
	200					
6	Amb to T1{1}			92	1.00	4-1 DISP
	200					
3	Amb to T2{1}			46	1.00	4-1 DISP
	200					
1	Amb to T3{1}			11	1.00	4-1 DISP
	229					
60	Hydrotest{1}	0	242		1.00	3-1 OCC
	219					
47	Sus.+T1{1}				1.00	5-1 CRUP
	<NOTE 1>					
46	Sus.+T2{1}				1.00	5-1 CRUP
	<NOTE 1>					
45	Sus.+T3{1}				1.00	5-1 CRUP
	<NOTE 1>					
A09 F-	Max P{1}					HOOP
59	88					
45	GR + Max P{1}	243			1.00	2-1 SUST
	88					
6	TR:Amb to T1{1}			92	1.00	4-1 DISP
	200					
6	Amb to T1{1}			92	1.00	4-1 DISP
	200					

circuitoprovabarre.txt

3	Amb to T2{1}			46	1.00	4-1	DISP
1	Amb to T3{1}			11	1.00	4-1	DISP
60	Hydrotest{1}	0	242		1.00	3-1	OCC
47	<NOTE 1> Sus.+T1{1}				1.00	5-1	CRUP
46	<NOTE 1> Sus.+T2{1}				1.00	5-1	CRUP
45	<NOTE 1> Sus.+T3{1}				1.00	5-1	CRUP
A11	Max P{1}						HOOP
59	88						
45	GR + Max P{1}	243			1.00	2-1	SUST
6	TR:Amb to T1{1}			92	1.00	4-1	DISP
6	Amb to T1{1}			92	1.00	4-1	DISP
3	Amb to T2{1}			46	1.00	4-1	DISP
1	Amb to T3{1}			11	1.00	4-1	DISP
60	Hydrotest{1}	0	242		1.00	3-1	OCC
47	<NOTE 1> Sus.+T1{1}				1.00	5-1	CRUP
46	<NOTE 1> Sus.+T2{1}				1.00	5-1	CRUP
45	<NOTE 1> Sus.+T3{1}				1.00	5-1	CRUP

□

CIRCUITOPROVABARRE

07/30/2010 CIRCUITO PROVA BARRE
BENTLEY

02:16 PM

AutoPIPE Plus 9.2.1

RESULT PAGE 101

EN 13480 (2002) CODE COMPLIANCE

(Moments in N.m) (Stress in N/mm2)

Point Code name Stress	Load Code combination Allow.	Ma (Sus.)	Mb (Occ.)	Mc (Exp.)	S.I.F	Eq. no.	Load type
A13	Max P{1}						HOOP
59	91						
39	GR + Max P{1}	143			1.00	2-1	SUST
10	TR:Amb to T2{1}			154	1.00	4-1	DISP
9	Amb to T1{1}			151	1.00	4-1	DISP
10	Amb to T2{1}			154	1.00	4-1	DISP
3	Amb to T3{1}			45	1.00	4-1	DISP

circuitoprovabarre.txt

53	Hydrotest{1}	0	142	1.00	3-1	OCC
	219					
	Sus.+T1{1}			1.00	5-1	CRUP
42	<NOTE 1>					
	Sus.+T2{1}			1.00	5-1	CRUP
42	<NOTE 1>					
	Sus.+T3{1}			1.00	5-1	CRUP
40	<NOTE 1>					
	F11 + Max P{1}					HOOP
59	91					
	GR + Max P{1}	178		1.00	2-1	SUST
41	91					
	TR:Amb to T1{1}			166	1.00	4-1 DISP
10	204					
	Amb to T1{1}			166	1.00	4-1 DISP
10	204					
	Amb to T2{1}			141	1.00	4-1 DISP
9	204					
	Amb to T3{1}			38	1.00	4-1 DISP
2	229					
	Hydrotest{1}	0	178	1.00	3-1	OCC
56	219					
	Sus.+T1{1}			1.00	5-1	CRUP
44	<NOTE 1>					
	Sus.+T2{1}			1.00	5-1	CRUP
44	<NOTE 1>					
	Sus.+T3{1}			1.00	5-1	CRUP
42	<NOTE 1>					
	F11 - Max P{1}					HOOP
59	91					
	GR + Max P{1}	96		1.00	2-1	SUST
36	91					
	TR:Amb to T1{1}			166	1.00	4-1 DISP
10	204					
	Amb to T1{1}			166	1.00	4-1 DISP
10	204					
	Amb to T2{1}			141	1.00	4-1 DISP
9	204					
	Amb to T3{1}			38	1.00	4-1 DISP
2	229					
	Hydrotest{1}	0	96	1.00	3-1	OCC
51	219					
	Sus.+T1{1}			1.00	5-1	CRUP
39	<NOTE 1>					
	Sus.+T2{1}			1.00	5-1	CRUP
39	<NOTE 1>					
	Sus.+T3{1}			1.00	5-1	CRUP
37	<NOTE 1>					
	F10 + Max P{1}					HOOP
59	91					
	GR + Max P{1}	60		1.00	2-1	SUST
34	91					
	TR:Amb to T1{1}			258	1.00	4-1 DISP
16	204					
	Amb to T1{1}			258	1.00	4-1 DISP
16	204					
	Amb to T2{1}			226	1.00	4-1 DISP
14	204					
	Amb to T3{1}			62	1.00	4-1 DISP
4	229					
	Hydrotest{1}	0	59	1.00	3-1	OCC
48	219					
	Sus.+T1{1}			1.00	5-1	CRUP
39	<NOTE 1>					
	Sus.+T2{1}			1.00	5-1	CRUP

circuitoprovabarre.txt

38 <NOTE 1>
 Sus.+T3{1} 1.00 5-1 CRUP
 35 <NOTE 1>

□

CIRCUITOPROVABARRE

07/30/2010 CIRCUITO PROVA BARRE
 BENTLEY

02:16 PM AutoPIPE Plus 9.2.1 RESULT PAGE 102

EN 13480 (2002) CODE COMPLIANCE

(Moments in N.m) (Stress in N/mm2)

Point Code name Stress	Load Code combination Allow.	Ma (Sus.)	Mb (Occ.)	Mc (Exp.)	S.I.F	Eq. no.	Load type
F10	- Max P{1}						HOOP
59	91						
34	GR + Max P{1}	60			1.00	2-1	SUST
16	91						
16	TR:Amb to T1{1}			258	1.00	4-1	DISP
16	204						
16	Amb to T1{1}			258	1.00	4-1	DISP
14	204						
14	Amb to T2{1}			226	1.00	4-1	DISP
4	204						
4	Amb to T3{1}			62	1.00	4-1	DISP
48	229						
48	Hydrotest{1}	0	59		1.00	3-1	OCC
39	219						
39	Sus.+T1{1}				1.00	5-1	CRUP
38	<NOTE 1>						
38	Sus.+T2{1}				1.00	5-1	CRUP
35	<NOTE 1>						
35	Sus.+T3{1}				1.00	5-1	CRUP
F16	+ Max P{1}						HOOP
59	91						
34	GR + Max P{1}	66			1.00	2-1	SUST
18	91						
18	TR:Amb to T1{1}			296	1.00	4-1	DISP
18	204						
18	Amb to T1{1}			296	1.00	4-1	DISP
16	204						
16	Amb to T2{1}			261	1.00	4-1	DISP
4	204						
4	Amb to T3{1}			72	1.00	4-1	DISP
49	229						
49	Hydrotest{1}	0	64		1.00	3-1	OCC
40	219						
40	Sus.+T1{1}				1.00	5-1	CRUP
39	<NOTE 1>						
39	Sus.+T2{1}				1.00	5-1	CRUP
35	<NOTE 1>						
35	Sus.+T3{1}				1.00	5-1	CRUP

circuitoprovabarre.txt

Code	Load	Ma	Mb	Mc	S.I.F	no.	type
F16	Max P{1}						HOOP
59	91						
	GR + Max P{1}	66			1.00	2-1	SUST
34	91						
	TR:Amb to T1{1}			296	1.00	4-1	DISP
18	204						
	Amb to T1{1}			296	1.00	4-1	DISP
18	204						
	Amb to T2{1}			261	1.00	4-1	DISP
16	204						
	Amb to T3{1}			72	1.00	4-1	DISP
4	229						
	Hydrotest{1}	0	64		1.00	3-1	OCC
49	219						
	Sus.+T1{1}				1.00	5-1	CRUP
40	<NOTE 1>						
	Sus.+T2{1}				1.00	5-1	CRUP
39	<NOTE 1>						
	Sus.+T3{1}				1.00	5-1	CRUP
35	<NOTE 1>						

Code	Load	Ma	Mb	Mc	S.I.F	no.	type
F09	Max P{1}						HOOP
59	91						
	GR + Max P{1}	12			1.00	2-1	SUST
31	91						
	TR:T2 to T3{1}			84	1.00	4-1	DISP
5	204						
	Amb to T1{1}			54	1.00	4-1	DISP
3	204						
	Amb to T2{1}			75	1.00	4-1	DISP
5	204						
	Amb to T3{1}			8	1.00	4-1	DISP
1	229						
	Hydrotest{1}	0	12		1.00	3-1	OCC
45	219						
	Sus.+T1{1}				1.00	5-1	CRUP
32	<NOTE 1>						
	Sus.+T2{1}				1.00	5-1	CRUP
32	<NOTE 1>						
	Sus.+T3{1}				1.00	5-1	CRUP
31	<NOTE 1>						

□

CIRCUITOPROVABARRE

07/30/2010 CIRCUITO PROVA BARRE
BENTLEY

02:16 PM

AutoPIPE Plus 9.2.1 RESULT PAGE 103

EN 13480 (2002) CODE COMPLIANCE

(Moments in N.m) (Stress in N/mm2)

Point Code	Load Code	Ma (Sus.)	Mb (Occ.)	Mc (Exp.)	S.I.F	Eq. no.	Load type
F08	Max P{1}						HOOP
59	91						
	GR + Max P{1}	32			1.00	2-1	SUST
32	91						

circuitoprovabarre.txt

5	TR:Amb to T1{1}		76	1.00	4-1	DISP
	204					
5	Amb to T1{1}		76	1.00	4-1	DISP
	204					
2	Amb to T2{1}		25	1.00	4-1	DISP
	204					
3	Amb to T3{1}		51	1.00	4-1	DISP
	229					
47	Hydrotest{1}	0 31		1.00	3-1	OCC
	219					
	Sus.+T1{1}			1.00	5-1	CRUP
33	<NOTE 1>					
	Sus.+T2{1}			1.00	5-1	CRUP
32	<NOTE 1>					
	Sus.+T3{1}			1.00	5-1	CRUP
33	<NOTE 1>					
F07	Max P{1}					HOOP
59	91					
	GR + Max P{1}	42		1.00	2-1	SUST
32	91					
	TR:Amb to T1{1}		116	1.00	4-1	DISP
7	204					
	Amb to T1{1}		116	1.00	4-1	DISP
7	204					
	Amb to T2{1}		55	1.00	4-1	DISP
3	204					
	Amb to T3{1}		64	1.00	4-1	DISP
4	229					
	Hydrotest{1}	0 40		1.00	3-1	OCC
47	219					
	Sus.+T1{1}			1.00	5-1	CRUP
35	<NOTE 1>					
	Sus.+T2{1}			1.00	5-1	CRUP
34	<NOTE 1>					
	Sus.+T3{1}			1.00	5-1	CRUP
34	<NOTE 1>					
F06 F+	Max P{1}					HOOP
59	91					
	GR + Max P{1}	42		1.00	2-1	SUST
32	91					
	TR:Amb to T1{1}		116	1.00	4-1	DISP
7	204					
	Amb to T1{1}		116	1.00	4-1	DISP
7	204					
	Amb to T2{1}		55	1.00	4-1	DISP
3	204					
	Amb to T3{1}		65	1.00	4-1	DISP
4	229					
	Hydrotest{1}	0 40		1.00	3-1	OCC
47	219					
	Sus.+T1{1}			1.00	5-1	CRUP
35	<NOTE 1>					
	Sus.+T2{1}			1.00	5-1	CRUP
34	<NOTE 1>					
	Sus.+T3{1}			1.00	5-1	CRUP
34	<NOTE 1>					
F06 F-	Max P{1}					HOOP
59	91					
	GR + Max P{1}	42		1.00	2-1	SUST
32	91					
	TR:Amb to T1{1}		116	1.00	4-1	DISP
7	204					
	Amb to T1{1}		116	1.00	4-1	DISP
7	204					
	Amb to T2{1}		55	1.00	4-1	DISP

circuitoprovabarre.txt

3	204	Amb to T3{1}			65	1.00	4-1	DISP
4	229	Hydrotest{1}	0	40		1.00	3-1	OCC
47	219	Sus.+T1{1}				1.00	5-1	CRUP
35	<NOTE 1>	Sus.+T2{1}				1.00	5-1	CRUP
34	<NOTE 1>	Sus.+T3{1}				1.00	5-1	CRUP
34	<NOTE 1>							

□

 CIRCUITOPROVABARRE

07/30/2010 CIRCUITO PROVA BARRE
 BENTLEY

02:16 PM

AutoPIPE Plus 9.2.1 RESULT PAGE 104

 EN 13480 (2002) CODE COMPLIANCE

(Moments in N.m) (Stress in N/mm2)

Point Code name Stress	Load Code combination Allow.	Ma (Sus.)	Mb (Occ.)	Mc (Exp.)	S.I.F	Eq. no.	Load type
F06 M 59	Max P{1} 91						HOOP
32	GR + Max P{1} 91	42			1.00	2-1	SUST
8	TR:Amb to T1{1} 204			133	1.00	4-1	DISP
8	Amb to T1{1} 204			133	1.00	4-1	DISP
4	Amb to T2{1} 204			69	1.00	4-1	DISP
4	Amb to T3{1} 204			70	1.00	4-1	DISP
47	Hydrotest{1} 229	0	40		1.00	3-1	OCC
35	<NOTE 1> 219				1.00	5-1	CRUP
34	<NOTE 1>				1.00	5-1	CRUP
34	<NOTE 1>				1.00	5-1	CRUP
F06 N+ 59	Max P{1} 91						HOOP
32	GR + Max P{1} 91	35			1.00	2-1	SUST
9	TR:Amb to T1{1} 204			144	1.00	4-1	DISP
9	Amb to T1{1} 204			144	1.00	4-1	DISP
5	Amb to T2{1} 204			79	1.00	4-1	DISP
5	Amb to T3{1} 204			72	1.00	4-1	DISP
5	Hydrotest{1} 229	0	33		1.00	3-1	OCC

circuitoprovabarre.txt

47	219							
	Sus.+T1{1}				1.00	5-1	CRUP	
35	<NOTE 1>							
	Sus.+T2{1}				1.00	5-1	CRUP	
34	<NOTE 1>							
	Sus.+T3{1}				1.00	5-1	CRUP	
33	<NOTE 1>							
	F06 N- Max P{1}						HOOP	
59	91							
	GR + Max P{1}		35		1.00	2-1	SUST	
32	91							
	TR:Amb to T1{1}			144	1.00	4-1	DISP	
9	204							
	Amb to T1{1}			144	1.00	4-1	DISP	
9	204							
	Amb to T2{1}			79	1.00	4-1	DISP	
5	204							
	Amb to T3{1}			72	1.00	4-1	DISP	
5	229							
	Hydrotest{1}		0	33	1.00	3-1	OCC	
47	219							
	Sus.+T1{1}				1.00	5-1	CRUP	
35	<NOTE 1>							
	Sus.+T2{1}				1.00	5-1	CRUP	
34	<NOTE 1>							
	Sus.+T3{1}				1.00	5-1	CRUP	
33	<NOTE 1>							
	F05 Max P{1}						HOOP	
59	91							
	GR + Max P{1}		35		1.00	2-1	SUST	
32	91							
	TR:Amb to T1{1}			144	1.00	4-1	DISP	
9	204							
	Amb to T1{1}			144	1.00	4-1	DISP	
9	204							
	Amb to T2{1}			79	1.00	4-1	DISP	
5	204							
	Amb to T3{1}			72	1.00	4-1	DISP	
5	229							
	Hydrotest{1}		0	33	1.00	3-1	OCC	
47	219							
	Sus.+T1{1}				1.00	5-1	CRUP	
35	<NOTE 1>							
	Sus.+T2{1}				1.00	5-1	CRUP	
34	<NOTE 1>							
	Sus.+T3{1}				1.00	5-1	CRUP	
33	<NOTE 1>							

□

 CIRCUITOPROVABARRE

07/30/2010 CIRCUITO PROVA BARRE
 BENTLEY

02:16 PM

AutoPIPE Plus 9.2.1 RESULT PAGE 105

EN 13480 (2002) CODE COMPLIANCE

(Moments in N.m) (Stress in N/mm2)

Point Load Ma Mb Mc Eq. Load
 Code Code

circuitoprovabarre.txt

name	combination	(Sus.)	(Occ.)	(Exp.)	S.I.F	no.	type
Stress	Allow.						
F04	+ Max P{1}						HOOP
59	91						
32	GR + Max P{1}	26			2.10	2-1	SUST
20	91						
20	TR:Amb to T1{1}			150	2.10	4-1	DISP
20	204						
20	Amb to T1{1}			150	2.10	4-1	DISP
11	204						
11	Amb to T2{1}			85	2.10	4-1	DISP
10	204						
10	Amb to T3{1}			73	2.10	4-1	DISP
47	229						
47	Hydrotest{1}	0	24		2.10	3-1	OCC
37	219						
37	Sus.+T1{1}				2.10	5-1	CRUP
35	<NOTE 1>						
35	Sus.+T2{1}				2.10	5-1	CRUP
35	<NOTE 1>						
35	Sus.+T3{1}				2.10	5-1	CRUP
35	<NOTE 1>						
F04	- Max P{1}						HOOP
59	91						
32	GR + Max P{1}	26			2.10	2-1	SUST
20	91						
20	TR:Amb to T1{1}			150	2.10	4-1	DISP
20	204						
20	Amb to T1{1}			150	2.10	4-1	DISP
11	204						
11	Amb to T2{1}			85	2.10	4-1	DISP
10	204						
10	Amb to T3{1}			73	2.10	4-1	DISP
47	229						
47	Hydrotest{1}	0	24		2.10	3-1	OCC
37	219						
37	Sus.+T1{1}				2.10	5-1	CRUP
35	<NOTE 1>						
35	Sus.+T2{1}				2.10	5-1	CRUP
35	<NOTE 1>						
35	Sus.+T3{1}				2.10	5-1	CRUP
35	<NOTE 1>						
F03	Max P{1}						HOOP
59	91						
31	GR + Max P{1}	17			1.00	2-1	SUST
10	91						
10	TR:Amb to T1{1}			155	1.00	4-1	DISP
10	204						
10	Amb to T1{1}			155	1.00	4-1	DISP
6	204						
6	Amb to T2{1}			91	1.00	4-1	DISP
5	204						
5	Amb to T3{1}			74	1.00	4-1	DISP
46	229						
46	Hydrotest{1}	0	16		1.00	3-1	OCC
34	219						
34	Sus.+T1{1}				1.00	5-1	CRUP
33	<NOTE 1>						
33	Sus.+T2{1}				1.00	5-1	CRUP
32	<NOTE 1>						
32	Sus.+T3{1}				1.00	5-1	CRUP
32	<NOTE 1>						
F13	+ Max P{1}						HOOP

circuitoprovabarre.txt

59	91							
	GR + Max P{1}	54			2.10	2-1	SUST	
35	91							
	TR:Amb to T1{1}			258	2.10	4-1	DISP	
34	204							
	Amb to T1{1}			258	2.10	4-1	DISP	
34	204							
	Amb to T2{1}			205	2.10	4-1	DISP	
27	204							
	Amb to T3{1}			84	2.10	4-1	DISP	
11	229							
	Hydrotest{1}	0	57		2.10	3-1	OCC	
50	219							
	Sus.+T1{1}				2.10	5-1	CRUP	
44	<NOTE 1>							
	Sus.+T2{1}				2.10	5-1	CRUP	
42	<NOTE 1>							
	Sus.+T3{1}				2.10	5-1	CRUP	
38	<NOTE 1>							

□

 CIRCUITOPROVABARRE

07/30/2010 CIRCUITO PROVA BARRE
 BENTLEY

02:16 PM

AutoPIPE Plus 9.2.1

RESULT PAGE 106

EN 13480 (2002) CODE COMPLIANCE

(Moments in N.m) (Stress in N/mm2)

Point Code name Stress	Load Code combination Allow.	Ma (Sus.)	Mb (Occ.)	Mc (Exp.)	S.I.F	Eq. no.	Load type
F13	- Max P{1}						HOOP
59	91						
	GR + Max P{1}	60			2.10	2-1	SUST
36	91						
	TR:Amb to T1{1}			276	2.10	4-1	DISP
36	204						
	Amb to T1{1}			276	2.10	4-1	DISP
36	204						
	Amb to T2{1}			212	2.10	4-1	DISP
28	245						
	Amb to T3{1}			84	2.10	4-1	DISP
11	229						
	Hydrotest{1}	0	63		2.10	3-1	OCC
51	219						
	Sus.+T1{1}				2.10	5-1	CRUP
45	<NOTE 1>						
	Sus.+T2{1}				2.10	5-1	CRUP
43	<NOTE 1>						
	Sus.+T3{1}				2.10	5-1	CRUP
38	<NOTE 1>						
F02	+ Max P{1}						HOOP
59	91						
	GR + Max P{1}	42			1.00	2-1	SUST
32	91						
	TR:Amb to T1{1}			303	1.00	4-1	DISP

circuitoprovabarre.txt

19	204						
	Amb to T1{1}			303	1.00	4-1	DISP
19	204						
	Amb to T2{1}			240	1.00	4-1	DISP
15	245						
	Amb to T3{1}			87	1.00	4-1	DISP
5	229						
	Hydrotest{1}	0	45		1.00	3-1	OCC
47	219						
	Sus.+T1{1}				1.00	5-1	CRUP
39	<NOTE 1>						
	Sus.+T2{1}				1.00	5-1	CRUP
37	<NOTE 1>						
	Sus.+T3{1}				1.00	5-1	CRUP
34	<NOTE 1>						
	F02 - Max P{1}						HOOP
59	91						
	GR + Max P{1}	42			1.00	2-1	SUST
32	91						
	TR:Amb to T1{1}			303	1.00	4-1	DISP
19	204						
	Amb to T1{1}			303	1.00	4-1	DISP
19	204						
	Amb to T2{1}			240	1.00	4-1	DISP
15	245						
	Amb to T3{1}			87	1.00	4-1	DISP
5	229						
	Hydrotest{1}	0	45		1.00	3-1	OCC
47	219						
	Sus.+T1{1}				1.00	5-1	CRUP
39	<NOTE 1>						
	Sus.+T2{1}				1.00	5-1	CRUP
37	<NOTE 1>						
	Sus.+T3{1}				1.00	5-1	CRUP
34	<NOTE 1>						
	F01 Max P{1}						HOOP
59	91						
	GR + Max P{1}	75			1.00	2-1	SUST
34	91						
	TR:Amb to T1{1}			327	1.00	4-1	DISP
20	204						
	Amb to T1{1}			327	1.00	4-1	DISP
20	204						
	Amb to T2{1}			264	1.00	4-1	DISP
16	245						
	Amb to T3{1}			89	1.00	4-1	DISP
6	229						
	Hydrotest{1}	0	72		1.00	3-1	OCC
49	219						
	Sus.+T1{1}				1.00	5-1	CRUP
41	<NOTE 1>						
	Sus.+T2{1}				1.00	5-1	CRUP
40	<NOTE 1>						
	Sus.+T3{1}				1.00	5-1	CRUP
36	<NOTE 1>						

□

 CIRCUITOPROVABARRE

07/30/2010 CIRCUITO PROVA BARRE
 BENTLEY

02:16 PM

AutoPIPE Plus 9.2.1

RESULT PAGE 107

circuitoprovabarre.txt

EN 13480 (2002) CODE COMPLIANCE

(Moments in N.m) (Stress in N/mm2)

Point Code name Stress	Load Code combination Allow.	Ma (Sus.)	Mb (Occ.)	Mc (Exp.)	S.I.F	Eq. Load no. type
A15 59	Max P{1} 91					HOOP
39	GR + Max P{1} 91	106			2.10	2-1 SUST
38	TR:Amb to T1{1} 204			333	2.10	4-1 DISP
38	Amb to T1{1} 204			333	2.10	4-1 DISP
31	Amb to T2{1} 245			271	2.10	4-1 DISP
10	Amb to T3{1} 229			89	2.10	4-1 DISP
54	Hydrotest{1} 219	0	103		2.10	3-1 OCC
49	Sus.+T1{1} <NOTE 1>				2.10	5-1 CRUP
47	Sus.+T2{1} <NOTE 1>				2.10	5-1 CRUP
42	Sus.+T3{1} <NOTE 1>				2.10	5-1 CRUP
A13 59	Max P{1} 88					HOOP
39	GR + Max P{1} 88	143			1.00	2-1 SUST
10	TR:Amb to T2{1} 200			154	1.00	4-1 DISP
9	Amb to T1{1} 200			151	1.00	4-1 DISP
10	Amb to T2{1} 200			154	1.00	4-1 DISP
3	Amb to T3{1} 229			45	1.00	4-1 DISP
53	Hydrotest{1} 219	0	142		1.00	3-1 OCC
42	Sus.+T1{1} <NOTE 1>				1.00	5-1 CRUP
42	Sus.+T2{1} <NOTE 1>				1.00	5-1 CRUP
40	Sus.+T3{1} <NOTE 1>				1.00	5-1 CRUP
A12 59	Max P{1} 88					HOOP
39	GR + Max P{1} 88	148			1.00	2-1 SUST
10	TR:Amb to T2{1} 200			162	1.00	4-1 DISP
10	Amb to T1{1} 200			160	1.00	4-1 DISP
10	Amb to T2{1} 200			162	1.00	4-1 DISP
3	Amb to T3{1} 229			47	1.00	4-1 DISP
54	Hydrotest{1} 219	0	147		1.00	3-1 OCC

circuitoprovabarre.txt

42	<NOTE 1>	Sus.+T1{1}			1.00	5-1	CRUP
42	<NOTE 1>	Sus.+T2{1}			1.00	5-1	CRUP
40	<NOTE 1>	Sus.+T3{1}			1.00	5-1	CRUP
59	A10 +	Max P{1}					HOOP
45	88	GR + Max P{1}	151		2.10	2-1	SUST
22	200	TR:Amb to T2{1}		166	2.10	4-1	DISP
21	200	Amb to T1{1}		164	2.10	4-1	DISP
22	200	Amb to T2{1}		166	2.10	4-1	DISP
6	229	Amb to T3{1}		48	2.10	4-1	DISP
59	219	Hydrotest{1}	0	149	2.10	3-1	OCC
50	<NOTE 1>	Sus.+T1{1}			2.10	5-1	CRUP
50	<NOTE 1>	Sus.+T2{1}			2.10	5-1	CRUP
46	<NOTE 1>	Sus.+T3{1}			2.10	5-1	CRUP

□

CIRCUITOPROVABARRE

07/30/2010 CIRCUITO PROVA BARRE
BENTLEY

02:16 PM

AutoPIPE Plus 9.2.1 RESULT PAGE 108

EN 13480 (2002) CODE COMPLIANCE

(Moments in N.m) (Stress in N/mm2)

Point Code	Load Code	Ma	Mb	Mc	Eq. no.	Load type
name	combination	(Sus.)	(Occ.)	(Exp.)	S.I.F	
Stress	Allow.					
59	A09 M Max P{1}					HOOP
37	88 GR + Max P{1}	110			1.00	2-1 SUST
6	200 TR:Amb to T1{1}			95	1.00	4-1 DISP
6	200 Amb to T1{1}			95	1.00	4-1 DISP
3	200 Amb to T2{1}			48	1.00	4-1 DISP
1	229 Amb to T3{1}			11	1.00	4-1 DISP
51	219 Hydrotest{1}	0	110		1.00	3-1 OCC
39	<NOTE 1> Sus.+T1{1}				1.00	5-1 CRUP
38	<NOTE 1> Sus.+T2{1}				1.00	5-1 CRUP

circuitoprovabarre.txt

37	<NOTE 1>	Sus.+T3{1}			1.00	5-1	CRUP
A09	N+	Max P{1}					HOOP
59		88					
44		GR + Max P{1}	225		1.00	2-1	SUST
6		88					
6		TR:Amb to T1{1}		94	1.00	4-1	DISP
6		200					
6		Amb to T1{1}		94	1.00	4-1	DISP
6		200					
3		Amb to T2{1}		43	1.00	4-1	DISP
3		200					
1		Amb to T3{1}		8	1.00	4-1	DISP
1		229					
59		Hydrotest{1}	0	225	1.00	3-1	OCC
59		219					
46	<NOTE 1>	Sus.+T1{1}			1.00	5-1	CRUP
45	<NOTE 1>	Sus.+T2{1}			1.00	5-1	CRUP
44	<NOTE 1>	Sus.+T3{1}			1.00	5-1	CRUP
A09	N-	Max P{1}					HOOP
59		88					
44		GR + Max P{1}	225		1.00	2-1	SUST
6		88					
6		TR:Amb to T1{1}		94	1.00	4-1	DISP
6		200					
6		Amb to T1{1}		94	1.00	4-1	DISP
6		200					
3		Amb to T2{1}		43	1.00	4-1	DISP
3		200					
1		Amb to T3{1}		8	1.00	4-1	DISP
1		229					
59		Hydrotest{1}	0	225	1.00	3-1	OCC
59		219					
46	<NOTE 1>	Sus.+T1{1}			1.00	5-1	CRUP
45	<NOTE 1>	Sus.+T2{1}			1.00	5-1	CRUP
44	<NOTE 1>	Sus.+T3{1}			1.00	5-1	CRUP
A08		Max P{1}					HOOP
59		88					
44		GR + Max P{1}	229		1.00	2-1	SUST
6		88					
6		TR:Amb to T1{1}		94	1.00	4-1	DISP
6		200					
6		Amb to T1{1}		94	1.00	4-1	DISP
6		200					
3		Amb to T2{1}		43	1.00	4-1	DISP
3		200					
0		Amb to T3{1}		8	1.00	4-1	DISP
0		229					
59		Hydrotest{1}	0	229	1.00	3-1	OCC
59		219					
46	<NOTE 1>	Sus.+T1{1}			1.00	5-1	CRUP
45	<NOTE 1>	Sus.+T2{1}			1.00	5-1	CRUP
44	<NOTE 1>	Sus.+T3{1}			1.00	5-1	CRUP

□

CIRCUITOPROVABARRE

07/30/2010 CIRCUITO PROVA BARRE
BENTLEY

02:16 PM

AutoPIPE Plus 9.2.1

RESULT PAGE 109

EN 13480 (2002) CODE COMPLIANCE

(Moments in N.m)

(Stress in N/mm2)

Point Code	Load Code	Ma (Sus.)	Mb (Occ.)	Mc (Exp.)	S.I.F	Eq. no.	Load type
A00	Max P{1}						HOOP
59	88						
42	GR + Max P{1}	204			1.00	2-1	SUST
	88						
3	TR:Amb to T1{1}			51	1.00	4-1	DISP
	200						
3	Amb to T1{1}			51	1.00	4-1	DISP
	200						
3	Amb to T2{1}			48	1.00	4-1	DISP
	200						
2	Amb to T3{1}			27	1.00	4-1	DISP
	229						
57	Hydrotest{1}	0	205		1.00	3-1	OCC
	219						
	Sus.+T1{1}				1.00	5-1	CRUP
44	<NOTE 1>						
	Sus.+T2{1}				1.00	5-1	CRUP
43	<NOTE 1>						
	Sus.+T3{1}				1.00	5-1	CRUP
43	<NOTE 1>						
A03 M	Max P{1}						HOOP
59	88						
32	GR + Max P{1}	34			1.00	2-1	SUST
	88						
3	TR:Amb to T1{1}			56	1.00	4-1	DISP
	200						
3	Amb to T1{1}			56	1.00	4-1	DISP
	200						
3	Amb to T2{1}			53	1.00	4-1	DISP
	200						
2	Amb to T3{1}			28	1.00	4-1	DISP
	229						
47	Hydrotest{1}	0	34		1.00	3-1	OCC
	219						
	Sus.+T1{1}				1.00	5-1	CRUP
33	<NOTE 1>						
	Sus.+T2{1}				1.00	5-1	CRUP
33	<NOTE 1>						
	Sus.+T3{1}				1.00	5-1	CRUP
32	<NOTE 1>						
A03 N+	Max P{1}						HOOP
59	88						
38	GR + Max P{1}	125			1.00	2-1	SUST
	88						
4	TR:Amb to T1{1}			57	1.00	4-1	DISP
	200						

circuitoprovabarre.txt

4	Amb to T1{1}			57	1.00	4-1	DISP
	200						
3	Amb to T2{1}			54	1.00	4-1	DISP
	200						
2	Amb to T3{1}			27	1.00	4-1	DISP
	229						
52	Hydrotest{1}	0	125		1.00	3-1	OCC
	219						
	Sus.+T1{1}				1.00	5-1	CRUP
39	<NOTE 1>						
	Sus.+T2{1}				1.00	5-1	CRUP
39	<NOTE 1>						
	Sus.+T3{1}				1.00	5-1	CRUP
38	<NOTE 1>						
A03	N- Max P{1}						HOOP
59	88						
	GR + Max P{1}	125			1.00	2-1	SUST
38	88						
	TR:Amb to T1{1}			57	1.00	4-1	DISP
4	200						
	Amb to T1{1}			57	1.00	4-1	DISP
4	200						
	Amb to T2{1}			54	1.00	4-1	DISP
3	200						
	Amb to T3{1}			27	1.00	4-1	DISP
2	229						
	Hydrotest{1}	0	125		1.00	3-1	OCC
52	219						
	Sus.+T1{1}				1.00	5-1	CRUP
39	<NOTE 1>						
	Sus.+T2{1}				1.00	5-1	CRUP
39	<NOTE 1>						
	Sus.+T3{1}				1.00	5-1	CRUP
38	<NOTE 1>						

□

CIRCUITOPROVABARRE

07/30/2010 CIRCUITO PROVA BARRE
BENTLEY

02:16 PM

AutoPIPE Plus 9.2.1

RESULT PAGE 110

EN 13480 (2002) CODE COMPLIANCE

(Moments in N.m) (Stress in N/mm2)

Point Code	Load Code combination	Ma (Sus.)	Mb (Occ.)	Mc (Exp.)	S.I.F	Eq. Load no.	Load type
A04	+ Max P{1}						HOOP
59	88						
	GR + Max P{1}	120			1.00	2-1	SUST
37	88						
	TR:Amb to T1{1}			51	1.00	4-1	DISP
3	200						
	Amb to T1{1}			51	1.00	4-1	DISP
3	200						
	Amb to T2{1}			50	1.00	4-1	DISP
3	200						

circuitoprovabarre.txt

2	Amb to T3{1}			24	1.00	4-1	DISP
52	229 Hydrotest{1}	0	119		1.00	3-1	OCC
38	219 Sus.+T1{1}				1.00	5-1	CRUP
38	<NOTE 1> Sus.+T2{1}				1.00	5-1	CRUP
38	<NOTE 1> Sus.+T3{1}				1.00	5-1	CRUP
59	A04 - Max P{1}						HOOP
37	88 GR + Max P{1}	120			1.00	2-1	SUST
3	88 TR:Amb to T1{1}			51	1.00	4-1	DISP
3	200 Amb to T1{1}			51	1.00	4-1	DISP
3	200 Amb to T2{1}			50	1.00	4-1	DISP
2	200 Amb to T3{1}			24	1.00	4-1	DISP
52	229 Hydrotest{1}	0	119		1.00	3-1	OCC
38	219 Sus.+T1{1}				1.00	5-1	CRUP
38	<NOTE 1> Sus.+T2{1}				1.00	5-1	CRUP
38	<NOTE 1> Sus.+T3{1}				1.00	5-1	CRUP
59	A14 + Max P{1}						HOOP
33	88 GR + Max P{1}	52			1.00	2-1	SUST
1	88 TR:Amb to T1{1}			13	1.00	4-1	DISP
1	200 Amb to T1{1}			13	1.00	4-1	DISP
0	200 Amb to T2{1}			0	1.00	4-1	DISP
1	200 Amb to T3{1}			9	1.00	4-1	DISP
48	229 Hydrotest{1}	0	53		1.00	3-1	OCC
33	219 Sus.+T1{1}				1.00	5-1	CRUP
33	<NOTE 1> Sus.+T2{1}				1.00	5-1	CRUP
33	<NOTE 1> Sus.+T3{1}				1.00	5-1	CRUP
59	A14 - Max P{1}						HOOP
33	88 GR + Max P{1}	52			1.00	2-1	SUST
1	88 TR:Amb to T1{1}			13	1.00	4-1	DISP
1	200 Amb to T1{1}			13	1.00	4-1	DISP
0	200 Amb to T2{1}			0	1.00	4-1	DISP
1	200 Amb to T3{1}			9	1.00	4-1	DISP
48	229 Hydrotest{1}	0	53		1.00	3-1	OCC
	219 Sus.+T1{1}				1.00	5-1	CRUP

circuitoprovabarre.txt

33 <NOTE 1>
 Sus.+T2{1} 1.00 5-1 CRUP
 33 <NOTE 1>
 Sus.+T3{1} 1.00 5-1 CRUP
 33 <NOTE 1>

□

 CIRCUITOPROVABARRE

07/30/2010 CIRCUITO PROVA BARRE
 BENTLEY

02:16 PM AutoPIPE Plus 9.2.1 RESULT PAGE 111

EN 13480 (2002) CODE COMPLIANCE

(Moments in N.m) (Stress in N/mm2)

Point Code name Stress	Load Code combination Allow.	Ma (Sus.)	Mb (Occ.)	Mc (Exp.)	S.I.F	Eq. Load no. type
A22 59	+ Max P{1} 88					HOOP
34	GR + Max P{1} 88	63			1.00	2-1 SUST
7	TR:Amb to T1{1} 200			116	1.00	4-1 DISP
7	Amb to T1{1} 200			116	1.00	4-1 DISP
5	Amb to T2{1} 200			81	1.00	4-1 DISP
4	Amb to T3{1} 229			64	1.00	4-1 DISP
48	Hydrotest{1} 219	0	61		1.00	3-1 OCC
36 <NOTE 1>	Sus.+T1{1}				1.00	5-1 CRUP
35 <NOTE 1>	Sus.+T2{1}				1.00	5-1 CRUP
35 <NOTE 1>	Sus.+T3{1}				1.00	5-1 CRUP
A22 59	- Max P{1} 88					HOOP
34	GR + Max P{1} 88	63			1.00	2-1 SUST
7	TR:Amb to T1{1} 200			116	1.00	4-1 DISP
7	Amb to T1{1} 200			116	1.00	4-1 DISP
5	Amb to T2{1} 200			81	1.00	4-1 DISP
4	Amb to T3{1} 229			64	1.00	4-1 DISP
48	Hydrotest{1} 219	0	61		1.00	3-1 OCC
36 <NOTE 1>	Sus.+T1{1}				1.00	5-1 CRUP
35 <NOTE 1>	Sus.+T2{1}				1.00	5-1 CRUP
35 <NOTE 1>	Sus.+T3{1}				1.00	5-1 CRUP

circuitoprovabarre.txt

35 <NOTE 1>

A16	Max P{1}								HOOP
59	88								
	GR + Max P{1}	100			1.00	2-1			SUST
36	88								
	TR:Amb to T1{1}			315	1.00	4-1			DISP
20	200								
	Amb to T1{1}			315	1.00	4-1			DISP
20	200								
	Amb to T2{1}			256	1.00	4-1			DISP
16	200								
	Amb to T3{1}			83	1.00	4-1			DISP
5	229								
	Hydrotest{1}	0	97		1.00	3-1			OCC
51	219								
	Sus.+T1{1}				1.00	5-1			CRUP
43	<NOTE 1>								
	Sus.+T2{1}				1.00	5-1			CRUP
41	<NOTE 1>								
	Sus.+T3{1}				1.00	5-1			CRUP
38	<NOTE 1>								

A15	+ Max P{1}								HOOP
59	88								
	GR + Max P{1}	106			2.10	2-1			SUST
40	88								
	TR:Amb to T3{1}			333	2.10	4-1			DISP
44	229								
	Amb to T1{1}			333	2.10	4-1			DISP
44	200								
	Amb to T2{1}			271	2.10	4-1			DISP
35	200								
	Amb to T3{1}			89	2.10	4-1			DISP
12	229								
	Hydrotest{1}	0	103		2.10	3-1			OCC
55	219								
	Sus.+T1{1}				2.10	5-1			CRUP
51	<NOTE 1>								
	Sus.+T2{1}				2.10	5-1			CRUP
49	<NOTE 1>								
	Sus.+T3{1}				2.10	5-1			CRUP
43	<NOTE 1>								

□

CIRCUITOPROVABARRE

07/30/2010 CIRCUITO PROVA BARRE

BENTLEY

02:16 PM

AutoPIPE Plus 9.2.1

RESULT PAGE 112

EN 13480 (2002) CODE COMPLIANCE

(Moments in N.m)

(Stress in N/mm2)

Point Code name Stress	Load Code combination Allow.	Ma (Sus.)	Mb (Occ.)	Mc (Exp.)	S.I.F	Eq. no.	Load type
------------------------	------------------------------	-----------	-----------	-----------	-------	---------	-----------

A15	- Max P{1}						HOOP
59	88						

circuitoprovabarre.txt

30	GR + Max P{1}	0	2.10	2-1	SUST
	88				
0	TR:Amb to T3{1}		0	2.10	4-1 DISP
	229				
0	Amb to T1{1}		0	2.10	4-1 DISP
	200				
0	Amb to T2{1}		0	2.10	4-1 DISP
	200				
0	Amb to T3{1}		0	2.10	4-1 DISP
	229				
45	Hydrotest{1}	0	0	2.10	3-1 OCC
	219				
30	Sus.+T1{1}			2.10	5-1 CRUP
	<NOTE 1>				
30	Sus.+T2{1}			2.10	5-1 CRUP
	<NOTE 1>				
30	Sus.+T3{1}			2.10	5-1 CRUP
	<NOTE 1>				
A17	Max P{1}				HOOP
59	88				
30	GR + Max P{1}	0	1.00	2-1	SUST
	88				
0	TR:Amb to T1{1}		0	1.00	4-1 DISP
	200				
0	Amb to T1{1}		0	1.00	4-1 DISP
	200				
0	Amb to T2{1}		0	1.00	4-1 DISP
	200				
0	Amb to T3{1}		0	1.00	4-1 DISP
	229				
45	Hydrotest{1}	0	0	1.00	3-1 OCC
	219				
30	Sus.+T1{1}			1.00	5-1 CRUP
	<NOTE 1>				
30	Sus.+T2{1}			1.00	5-1 CRUP
	<NOTE 1>				
30	Sus.+T3{1}			1.00	5-1 CRUP
	<NOTE 1>				
A18	+ Max P{1}				HOOP
59	88				
30	GR + Max P{1}	0	1.00	2-1	SUST
	88				
0	TR:T2 to T3{1}		0	1.00	4-1 DISP
	200				
0	Amb to T1{1}		0	1.00	4-1 DISP
	200				
0	Amb to T2{1}		0	1.00	4-1 DISP
	200				
0	Amb to T3{1}		0	1.00	4-1 DISP
	229				
45	Hydrotest{1}	0	0	1.00	3-1 OCC
	219				
30	Sus.+T1{1}			1.00	5-1 CRUP
	<NOTE 1>				
30	Sus.+T2{1}			1.00	5-1 CRUP
	<NOTE 1>				
30	Sus.+T3{1}			1.00	5-1 CRUP
	<NOTE 1>				
A18	- Max P{1}				HOOP
59	88				
30	GR + Max P{1}	0	1.00	2-1	SUST
	88				
0	TR:T2 to T3{1}		0	1.00	4-1 DISP
	200				
0	Amb to T1{1}		0	1.00	4-1 DISP

circuitoprovabarre.txt

0	200	Amb to T2{1}	0	1.00	4-1	DISP
0	200	Amb to T3{1}	0	1.00	4-1	DISP
0	229	Hydrotest{1}	0	0	1.00	3-1 OCC
45	219	Sus.+T1{1}			1.00	5-1 CRUP
30	<NOTE 1>	Sus.+T2{1}			1.00	5-1 CRUP
30	<NOTE 1>	Sus.+T3{1}			1.00	5-1 CRUP
30	<NOTE 1>					

□

CIRCUITOPROVABARRE

07/30/2010 CIRCUITO PROVA BARRE
BENTLEY

02:16 PM

AutoPIPE Plus 9.2.1 RESULT PAGE 113

EN 13480 (2002) CODE COMPLIANCE

(Moments in N.m) (Stress in N/mm2)

Point Code	Load Code	Ma (Sus.)	Mb (Occ.)	Mc (Exp.)	S.I.F	Eq. Load no. type
A19	+ Max P{1}					HOOP
59	88					
30	GR + Max P{1}	0			1.00	2-1 SUST
	88					
0	TR:T2 to T3{1}			0	1.00	4-1 DISP
0	200					
0	Amb to T1{1}			0	1.00	4-1 DISP
0	200					
0	Amb to T2{1}			0	1.00	4-1 DISP
0	200					
0	Amb to T3{1}			0	1.00	4-1 DISP
0	229					
45	Hydrotest{1}	0	0		1.00	3-1 OCC
45	219					
	Sus.+T1{1}				1.00	5-1 CRUP
30	<NOTE 1>					
	Sus.+T2{1}				1.00	5-1 CRUP
30	<NOTE 1>					
	Sus.+T3{1}				1.00	5-1 CRUP
30	<NOTE 1>					
B03	Max P{1}					HOOP
58	86					
40	GR + Max P{1}	60			2.00	2-1 SUST
	86					
10	TR:Amb to T2{1}			43	2.00	4-1 DISP
10	197					
	Amb to T1{1}			37	2.00	4-1 DISP
9	197					
	Amb to T2{1}			43	2.00	4-1 DISP
10	197					
	Amb to T3{1}			8	2.00	4-1 DISP

circuitoprovabarre.txt

2	223							
	Hydrotest{1}	0	61		2.00	3-1	OCC	
55	219							
	Sus.+T1{1}				2.00	5-1	CRUP	
42	<NOTE 1>							
	Sus.+T2{1}				2.00	5-1	CRUP	
43	<NOTE 1>							
	Sus.+T3{1}				2.00	5-1	CRUP	
41	<NOTE 1>							
A19	- Max P{1}							HOOP
51	88							
	GR + Max P{1}	0			1.00	2-1	SUST	
26	88							
	TR:T2 to T3{1}			0	1.00	4-1	DISP	
0	200							
	Amb to T1{1}			0	1.00	4-1	DISP	
0	200							
	Amb to T2{1}			0	1.00	4-1	DISP	
0	200							
	Amb to T3{1}			0	1.00	4-1	DISP	
0	229							
	Hydrotest{1}	0	0		1.00	3-1	OCC	
39	219							
	Sus.+T1{1}				1.00	5-1	CRUP	
26	<NOTE 1>							
	Sus.+T2{1}				1.00	5-1	CRUP	
26	<NOTE 1>							
	Sus.+T3{1}				1.00	5-1	CRUP	
26	<NOTE 1>							
A20	Max P{1}							HOOP
51	88							
	GR + Max P{1}	0			1.00	2-1	SUST	
26	88							
	TR:T1 to T3{1}			0	1.00	4-1	DISP	
0	200							
	Amb to T1{1}			0	1.00	4-1	DISP	
0	200							
	Amb to T2{1}			0	1.00	4-1	DISP	
0	200							
	Amb to T3{1}			0	1.00	4-1	DISP	
0	229							
	Hydrotest{1}	0	0		1.00	3-1	OCC	
39	219							
	Sus.+T1{1}				1.00	5-1	CRUP	
26	<NOTE 1>							
	Sus.+T2{1}				1.00	5-1	CRUP	
26	<NOTE 1>							
	Sus.+T3{1}				1.00	5-1	CRUP	
26	<NOTE 1>							

□

 CIRCUITOPROVABARRE

07/30/2010 CIRCUITO PROVA BARRE
 BENTLEY

02:16 PM

AutoPIPE Plus 9.2.1

RESULT PAGE 114

 EN 13480 (2002) CODE COMPLIANCE

(Moments in N.m)

(Stress in N/mm2)

circuitoprovabarre.txt

Point Code	Load Code	Ma	Mb	Mc	S.I.F	Eq. no.	Load type
name	combination	(Sus.)	(Occ.)	(Exp.)			
Stress	Allow.						
H01 M	Max P{1}						HOOP
44	121						
	GR + Max P{1}	5			1.00	2-1	SUST
35	121						
	TR:Amb to T1{1}			17	1.00	4-1	DISP
41	247						
	Amb to T1{1}			17	1.00	4-1	DISP
41	247						
	Amb to T2{1}			8	1.00	4-1	DISP
19	245						
	Amb to T3{1}			0	1.00	4-1	DISP
1	229						
	Hydrotest{1}	0	5		1.00	3-1	OCC
47	219						
	Sus.+T1{1}				1.00	5-1	CRUP
49	<NOTE 1>						
	Sus.+T2{1}				1.00	5-1	CRUP
42	<NOTE 1>						
	Sus.+T3{1}				1.00	5-1	CRUP
36	<NOTE 1>						
H01 F+	Max P{1}						HOOP
44	121						
	GR + Max P{1}	5			1.00	2-1	SUST
35	121						
	TR:Amb to T1{1}			17	1.00	4-1	DISP
40	247						
	Amb to T1{1}			17	1.00	4-1	DISP
40	247						
	Amb to T2{1}			8	1.00	4-1	DISP
19	245						
	Amb to T3{1}			0	1.00	4-1	DISP
1	229						
	Hydrotest{1}	0	5		1.00	3-1	OCC
47	219						
	Sus.+T1{1}				1.00	5-1	CRUP
49	<NOTE 1>						
	Sus.+T2{1}				1.00	5-1	CRUP
42	<NOTE 1>						
	Sus.+T3{1}				1.00	5-1	CRUP
36	<NOTE 1>						
H01 F-	Max P{1}						HOOP
44	121						
	GR + Max P{1}	5			1.00	2-1	SUST
35	121						
	TR:Amb to T1{1}			17	1.00	4-1	DISP
40	247						
	Amb to T1{1}			17	1.00	4-1	DISP
40	247						
	Amb to T2{1}			8	1.00	4-1	DISP
19	245						
	Amb to T3{1}			0	1.00	4-1	DISP
1	229						
	Hydrotest{1}	0	5		1.00	3-1	OCC
47	219						
	Sus.+T1{1}				1.00	5-1	CRUP
49	<NOTE 1>						
	Sus.+T2{1}				1.00	5-1	CRUP
42	<NOTE 1>						
	Sus.+T3{1}				1.00	5-1	CRUP
36	<NOTE 1>						

circuitoprovabarre.txt

Point Code	Load Code	Ma (Sus.)	Mb (Occ.)	Mc (Exp.)	S.I.F	Eq. no.	Load type
H01 N+	Max P{1}						HOOP
44	121						
	GR + Max P{1}	5			1.00	2-1	SUST
35	121						
	TR:Amb to T1{1}			17	1.00	4-1	DISP
41	247						
	Amb to T1{1}			17	1.00	4-1	DISP
41	247						
	Amb to T2{1}			8	1.00	4-1	DISP
19	245						
	Amb to T3{1}			0	1.00	4-1	DISP
1	229						
	Hydrotest{1}	0	5		1.00	3-1	OCC
46	219						
	Sus.+T1{1}				1.00	5-1	CRUP
48	<NOTE 1>						
	Sus.+T2{1}				1.00	5-1	CRUP
41	<NOTE 1>						
	Sus.+T3{1}				1.00	5-1	CRUP
35	<NOTE 1>						

□

CIRCUITOPROVABARRE

07/30/2010 CIRCUITO PROVA BARRE
BENTLEY

02:16 PM

AutoPIPE Plus 9.2.1

RESULT PAGE 115

EN 13480 (2002) CODE COMPLIANCE

(Moments in N.m)

(Stress in N/mm2)

Point Code	Load Code	Ma (Sus.)	Mb (Occ.)	Mc (Exp.)	S.I.F	Eq. no.	Load type
H01 N-	Max P{1}						HOOP
44	91						
	GR + Max P{1}	5			1.00	2-1	SUST
35	91						
	TR:Amb to T1{1}			17	1.00	4-1	DISP
41	204						
	Amb to T1{1}			17	1.00	4-1	DISP
41	204						
	Amb to T2{1}			8	1.00	4-1	DISP
19	245						
	Amb to T3{1}			0	1.00	4-1	DISP
1	229						
	Hydrotest{1}	0	5		1.00	3-1	OCC
46	219						
	Sus.+T1{1}				1.00	5-1	CRUP
48	<NOTE 1>						
	Sus.+T2{1}				1.00	5-1	CRUP
41	<NOTE 1>						
	Sus.+T3{1}				1.00	5-1	CRUP
35	<NOTE 1>						

K01	Max P{1}						HOOP
48	88						
	GR + Max P{1}	0			1.00	2-1	SUST

circuitoprovabarre.txt

25	88							
	TR:T2 to T3{1}			0	1.00	4-1	DISP	
0	200							
	Amb to T1{1}			0	1.00	4-1	DISP	
0	247							
	Amb to T2{1}			0	1.00	4-1	DISP	
0	200							
	Amb to T3{1}			0	1.00	4-1	DISP	
0	229							
	Hydrotest{1}		0	0	1.00	3-1	OCC	
37	219							
	Sus.+T1{1}				1.00	5-1	CRUP	
25	<NOTE 1>							
	Sus.+T2{1}				1.00	5-1	CRUP	
25	<NOTE 1>							
	Sus.+T3{1}				1.00	5-1	CRUP	
25	<NOTE 1>							
D03	Max P{1}							HOOP
48	88							
	GR + Max P{1}		0		2.10	2-1	SUST	
25	88							
	TR:Amb to T2{1}			0	2.10	4-1	DISP	
0	200							
	Amb to T1{1}			0	2.10	4-1	DISP	
0	247							
	Amb to T2{1}			0	2.10	4-1	DISP	
0	200							
	Amb to T3{1}			0	2.10	4-1	DISP	
0	229							
	Hydrotest{1}		0	0	2.10	3-1	OCC	
37	219							
	Sus.+T1{1}				2.10	5-1	CRUP	
25	<NOTE 1>							
	Sus.+T2{1}				2.10	5-1	CRUP	
25	<NOTE 1>							
	Sus.+T3{1}				2.10	5-1	CRUP	
25	<NOTE 1>							
F13	Max P{1}							HOOP
44	91							
	GR + Max P{1}		6		2.10	2-1	SUST	
33	91							
	TR:T1 to T3{1}			18	2.10	4-1	DISP	
37	204							
	Amb to T1{1}			18	2.10	4-1	DISP	
36	204							
	Amb to T2{1}			7	2.10	4-1	DISP	
14	245							
	Amb to T3{1}			0	2.10	4-1	DISP	
1	229							
	Hydrotest{1}		0	6	2.10	3-1	OCC	
44	219							
	Sus.+T1{1}				2.10	5-1	CRUP	
42	<NOTE 1>							
	Sus.+T2{1}				2.10	5-1	CRUP	
36	<NOTE 1>							
	Sus.+T3{1}				2.10	5-1	CRUP	
33	<NOTE 1>							

□

 CIRCUITOPROVABARRE

07/30/2010 CIRCUITO PROVA BARRE
 BENTLEY

02:16 PM

EN 13480 (2002) CODE COMPLIANCE

(Moments in N.m) (Stress in N/mm2)

Point Code	Load Code	Ma	Mb	Mc	S.I.F	Eq. no.	Load type
name	combination	(Sus.)	(Occ.)	(Exp.)			
Stress	Allow.						
I01	Max P{1}						HOOP
44	121						
	GR + Max P{1}	0			1.00	2-1	SUST
23	121						
	TR:Amb to T3{1}			0	1.00	4-1	DISP
0	229						
	Amb to T1{1}			0	1.00	4-1	DISP
0	247						
	Amb to T2{1}			0	1.00	4-1	DISP
0	245						
	Amb to T3{1}			0	1.00	4-1	DISP
0	229						
	Hydrotest{1}	0	0		1.00	3-1	OCC
35	219						
	Sus.+T1{1}				1.00	5-1	CRUP
23	<NOTE 1>						
	Sus.+T2{1}				1.00	5-1	CRUP
23	<NOTE 1>						
	Sus.+T3{1}				1.00	5-1	CRUP
23	<NOTE 1>						
I02	Max P{1}						HOOP
44	121						
	GR + Max P{1}	0			1.00	2-1	SUST
23	121						
	TR:Amb to T3{1}			0	1.00	4-1	DISP
0	229						
	Amb to T1{1}			0	1.00	4-1	DISP
0	247						
	Amb to T2{1}			0	1.00	4-1	DISP
0	245						
	Amb to T3{1}			0	1.00	4-1	DISP
0	229						
	Hydrotest{1}	0	0		1.00	3-1	OCC
35	219						
	Sus.+T1{1}				1.00	5-1	CRUP
23	<NOTE 1>						
	Sus.+T2{1}				1.00	5-1	CRUP
23	<NOTE 1>						
	Sus.+T3{1}				1.00	5-1	CRUP
23	<NOTE 1>						
H03	Max P{1}						HOOP
44	121						
	GR + Max P{1}	0			2.10	2-1	SUST
23	121						
	TR:Amb to T1{1}			0	2.10	4-1	DISP
0	247						
	Amb to T1{1}			0	2.10	4-1	DISP
0	247						
	Amb to T2{1}			0	2.10	4-1	DISP
0	245						
	Amb to T3{1}			0	2.10	4-1	DISP
0	229						

circuitoprovabarre.txt

35	H05 F+ Max P{1}			2.10	3-1	OCC
	219	0	0			
	Sus.+T1{1}			2.10	5-1	CRUP
23	<NOTE 1>					
	Sus.+T2{1}			2.10	5-1	CRUP
23	<NOTE 1>					
	Sus.+T3{1}			2.10	5-1	CRUP
23	<NOTE 1>					
	H05 F+ Max P{1}					HOOP
44	121					
	GR + Max P{1}	3		1.00	2-1	SUST
30	121					
	TR:T1 to T3{1}			15	1.00	4-1 DISP
36	229					
	Amb to T1{1}			15	1.00	4-1 DISP
35	247					
	Amb to T2{1}			6	1.00	4-1 DISP
16	245					
	Amb to T3{1}			1	1.00	4-1 DISP
1	229					
	Hydrotest{1}	0	3	1.00	3-1	OCC
42	219					
	Sus.+T1{1}			1.00	5-1	CRUP
41	<NOTE 1>					
	Sus.+T2{1}			1.00	5-1	CRUP
35	<NOTE 1>					
	Sus.+T3{1}			1.00	5-1	CRUP
30	<NOTE 1>					

□

CIRCUITOPROVABARRE

07/30/2010 CIRCUITO PROVA BARRE
BENTLEY

02:16 PM

AutoPIPE Plus 9.2.1

RESULT PAGE 117

EN 13480 (2002) CODE COMPLIANCE

(Moments in N.m) (Stress in N/mm2)

Point Code	Load Code combination	Ma (Sus.)	Mb (Occ.)	Mc (Exp.)	S.I.F	Eq. Load no.	Load type
H05 F-	Max P{1}						HOOP
44	121						
	GR + Max P{1}	3			1.00	2-1	SUST
30	121						
	TR:T1 to T3{1}			15	1.00	4-1	DISP
36	229						
	Amb to T1{1}			15	1.00	4-1	DISP
35	247						
	Amb to T2{1}			6	1.00	4-1	DISP
16	245						
	Amb to T3{1}			1	1.00	4-1	DISP
1	229						
	Hydrotest{1}	0	3		1.00	3-1	OCC
42	219						
	Sus.+T1{1}				1.00	5-1	CRUP
41	<NOTE 1>						

circuitoprovabarre.txt

35	<NOTE 1>	Sus.+T2{1}			1.00	5-1	CRUP
30	<NOTE 1>	Sus.+T3{1}			1.00	5-1	CRUP
44	H05 M	Max P{1}					HOOP
30		GR + Max P{1}	3		1.00	2-1	SUST
36		TR:T1 to T3{1}		15	1.00	4-1	DISP
35		Amb to T1{1}		15	1.00	4-1	DISP
15		Amb to T2{1}		6	1.00	4-1	DISP
1		Amb to T3{1}		1	1.00	4-1	DISP
42		Hydrotest{1}	0	3	1.00	3-1	OCC
42	<NOTE 1>	Sus.+T1{1}			1.00	5-1	CRUP
36	<NOTE 1>	Sus.+T2{1}			1.00	5-1	CRUP
31	<NOTE 1>	Sus.+T3{1}			1.00	5-1	CRUP
44	H05 N+	Max P{1}					HOOP
30		GR + Max P{1}	3		1.00	2-1	SUST
36		TR:T1 to T3{1}		15	1.00	4-1	DISP
34		Amb to T1{1}		14	1.00	4-1	DISP
15		Amb to T2{1}		6	1.00	4-1	DISP
1		Amb to T3{1}		1	1.00	4-1	DISP
42		Hydrotest{1}	0	3	1.00	3-1	OCC
42	<NOTE 1>	Sus.+T1{1}			1.00	5-1	CRUP
36	<NOTE 1>	Sus.+T2{1}			1.00	5-1	CRUP
31	<NOTE 1>	Sus.+T3{1}			1.00	5-1	CRUP
44	H05 N-	Max P{1}					HOOP
30		GR + Max P{1}	3		1.00	2-1	SUST
36		TR:T1 to T3{1}		15	1.00	4-1	DISP
34		Amb to T1{1}		14	1.00	4-1	DISP
15		Amb to T2{1}		6	1.00	4-1	DISP
1		Amb to T3{1}		1	1.00	4-1	DISP
42		Hydrotest{1}	0	3	1.00	3-1	OCC
42	<NOTE 1>	Sus.+T1{1}			1.00	5-1	CRUP
36	<NOTE 1>	Sus.+T2{1}			1.00	5-1	CRUP
31	<NOTE 1>	Sus.+T3{1}			1.00	5-1	CRUP

circuitoprovabarre.txt

□

 CIRCUITOPROVABARRE

07/30/2010 CIRCUITO PROVA BARRE
 BENTLEY

02:16 PM AutoPIPE Plus 9.2.1 RESULT PAGE 118

EN 13480 (2002) CODE COMPLIANCE

(Moments in N.m) (Stress in N/mm2)

Point Code name Stress	Load Code combination Allow.	Ma (Sus.)	Mb (Occ.)	Mc (Exp.)	S.I.F	Eq. Load no. type
H12 44	Max P{1} 121					HOOP
28	GR + Max P{1} 121	2			1.00	2-1 SUST
34	TR:T1 to T3{1} 229			14	1.00	4-1 DISP
32	Amb to T1{1} 247			14	1.00	4-1 DISP
14	Amb to T2{1} 245			6	1.00	4-1 DISP
1	Amb to T3{1} 229			1	1.00	4-1 DISP
40	Hydrotest{1} 219	0	2		1.00	3-1 OCC
39	Sus.+T1{1} <NOTE 1>				1.00	5-1 CRUP
33	Sus.+T2{1} <NOTE 1>				1.00	5-1 CRUP
29	Sus.+T3{1} <NOTE 1>				1.00	5-1 CRUP
H04 44	Max P{1} 121					HOOP
26	GR + Max P{1} 121	1			1.00	2-1 SUST
31	TR:T1 to T3{1} 229			13	1.00	4-1 DISP
30	Amb to T1{1} 247			12	1.00	4-1 DISP
13	Amb to T2{1} 245			5	1.00	4-1 DISP
1	Amb to T3{1} 229			1	1.00	4-1 DISP
38	Hydrotest{1} 219	0	1		1.00	3-1 OCC
36	Sus.+T1{1} <NOTE 1>				1.00	5-1 CRUP
30	Sus.+T2{1} <NOTE 1>				1.00	5-1 CRUP
26	Sus.+T3{1} <NOTE 1>				1.00	5-1 CRUP
H02 44	Max P{1} 121					HOOP
25	GR + Max P{1} 121	1			1.00	2-1 SUST

circuitoprovabarre.txt

30	TR:T1 to T3{1}			13	1.00	4-1	DISP
	229						
29	Amb to T1{1}			12	1.00	4-1	DISP
	247						
13	Amb to T2{1}			5	1.00	4-1	DISP
	245						
1	Amb to T3{1}			1	1.00	4-1	DISP
	229						
37	Hydrotest{1}	0	1		1.00	3-1	OCC
	219						
	Sus.+T1{1}				1.00	5-1	CRUP
35	<NOTE 1>						
	Sus.+T2{1}				1.00	5-1	CRUP
29	<NOTE 1>						
	Sus.+T3{1}				1.00	5-1	CRUP
26	<NOTE 1>						
G01	Max P{1}						HOOP
38	91						
	GR + Max P{1}	0			1.00	2-1	SUST
19	91						
	TR:T1 to T2{1}			0	1.00	4-1	DISP
0	204						
	Amb to T1{1}			0	1.00	4-1	DISP
0	204						
	Amb to T2{1}			0	1.00	4-1	DISP
0	204						
	Amb to T3{1}			0	1.00	4-1	DISP
0	229						
	Hydrotest{1}	0	0		1.00	3-1	OCC
29	219						
	Sus.+T1{1}				1.00	5-1	CRUP
19	<NOTE 1>						
	Sus.+T2{1}				1.00	5-1	CRUP
19	<NOTE 1>						
	Sus.+T3{1}				1.00	5-1	CRUP
19	<NOTE 1>						

□

CIRCUITOPROVABARRE

07/30/2010 CIRCUITO PROVA BARRE
BENTLEY

02:16 PM

AutoPIPE Plus 9.2.1

RESULT PAGE 119

EN 13480 (2002) CODE COMPLIANCE

(Moments in N.m)

(Stress in N/mm2)

Point Code name	Load Code combination	Ma (Sus.)	Mb (Occ.)	Mc (Exp.)	S.I.F	Eq. Load no. type
F04	Max P{1}					HOOP
38	91					
	GR + Max P{1}	0			2.10	2-1 SUST
19	91					
	TR:Amb to T1{1}			0	2.10	4-1 DISP
0	204					
	Amb to T1{1}			0	2.10	4-1 DISP
0	204					

circuitoprovabarre.txt

0	Amb to T2{1}			0	2.10	4-1	DISP
0	204 Amb to T3{1}			0	2.10	4-1	DISP
0	229 Hydrotest{1}	0	0		2.10	3-1	OCC
29	219 Sus.+T1{1}				2.10	5-1	CRUP
19	<NOTE 1> Sus.+T2{1}				2.10	5-1	CRUP
19	<NOTE 1> Sus.+T3{1}				2.10	5-1	CRUP
19	<NOTE 1>						
C01	Max P{1}						HOOP
38	88 GR + Max P{1}	0			1.00	2-1	SUST
19	88 TR:Amb to T1{1}			0	1.00	4-1	DISP
0	200 Amb to T1{1}			0	1.00	4-1	DISP
0	200 Amb to T2{1}			0	1.00	4-1	DISP
0	200 Amb to T3{1}			0	1.00	4-1	DISP
0	223 Hydrotest{1}	0	0		1.00	3-1	OCC
29	219 Sus.+T1{1}				1.00	5-1	CRUP
19	<NOTE 1> Sus.+T2{1}				1.00	5-1	CRUP
19	<NOTE 1> Sus.+T3{1}				1.00	5-1	CRUP
19	<NOTE 1>						
A07	Max P{1}						HOOP
38	88 GR + Max P{1}	0			2.10	2-1	SUST
19	88 TR:Amb to T1{1}			0	2.10	4-1	DISP
0	200 Amb to T1{1}			0	2.10	4-1	DISP
0	200 Amb to T2{1}			0	2.10	4-1	DISP
0	200 Amb to T3{1}			0	2.10	4-1	DISP
0	223 Hydrotest{1}	0	0		2.10	3-1	OCC
29	219 Sus.+T1{1}				2.10	5-1	CRUP
19	<NOTE 1> Sus.+T2{1}				2.10	5-1	CRUP
19	<NOTE 1> Sus.+T3{1}				2.10	5-1	CRUP
19	<NOTE 1>						

*** NOTE 1: No allowable stress could be calculated. ***
 *** Mechanical properties are outside of temperature range. ***

□

 CIRCUIOPROVABARRE

07/30/2010 CIRCUITO PROVA BARRE
 BENTLEY

02:16 PM

AutoPIPE Plus 9.2.1

RESULT PAGE 120

R E S U L T S U M M A R Y

Maximum displacements (mm)

Maximum X :	2.739	Point : F11	Load Comb.: Gravity{1}
Maximum Y :	22.248	Point : J04	Load Comb.: GRT2{1}
Maximum Z :	-53.524	Point : A20	Load Comb.: GRT1{1}
Max. total:	53.608	Point : A20	Load Comb.: GRT1{1}

Maximum rotations (deg)

Maximum X :	1.157	Point : H02	Load Comb.: GRT1{1}
Maximum Y :	0.122	Point : F11	Load Comb.: Gravity{1}
Maximum Z :	0.017	Point : H01 F	Load Comb.: Gravity{1}
Max. total:	1.158	Point : H02	Load Comb.: GRT1{1}

Maximum restraint forces (N)

Maximum X :	42	Point : A26	Load Comb.: Gravity{1}
Maximum Y :	358	Point : F16	Load Comb.: Thermal 1{1}
Maximum Z :	-6421	Point : A26	Load Comb.: GRT1{1}
Max. total:	6421	Point : A26	Load Comb.: GRT1{1}

Maximum restraint moments (N.m)

Results for this section are zero

□

CIRCUITOPROVABARRE

07/30/2010 CIRCUITO PROVA BARRE
BENTLEY

02:16 PM

AutoPIPE Plus 9.2.1

RESULT PAGE 121

circuitoprovabarre.txt

R E S U L T S U M M A R Y

Maximum pipe forces (N)

Maximum X :	-44	Point : A10	Load Comb.: Gravity{1}
Maximum Y :	289	Point : F13	Load Comb.: Thermal 1{1}
Maximum Z :	6349	Point : A10	Load Comb.: GRT2{1}
Max. total:	6350	Point : A10	Load Comb.: GRT2{1}

Maximum pipe moments (N.m)

Maximum X :	479	Point : A26	Load Comb.: GRT1{1}
Maximum Y :	178	Point : F11	Load Comb.: Gravity{1}
Maximum Z :	-4	Point : A09 F	Load Comb.: Gravity{1}
Max. total:	480	Point : A26	Load Comb.: GRT1{1}

□

CIRCUITOPROVABARRE

07/30/2010 CIRCUITO PROVA BARRE
BENTLEY

02:16 PM

AutoPIPE Plus 9.2.1

RESULT PAGE 122

R E S U L T S U M M A R Y

Maximum sustained stress

Point	:	H06
Stress N/mm2	:	85
Allowable N/mm2	:	121
Ratio	:	0.70
Load combination	:	GR + Max P{1}

Maximum displacement stress

Point	:	H06
-------	---	-----

circuitprovabarre.txt
Stress N/mm2 : 66
Allowable N/mm2 : 247
Ratio : 0.27
Load combination : Max Range

Maximum occasional stress

Point : H06
Stress N/mm2 : 96
Allowable N/mm2 : 219
Ratio : 0.44
Load combination : Hydrotest{1}

Maximum hoop stress

Point : B06
Stress N/mm2 : 67
Allowable N/mm2 : 86
Ratio : 0.78
Load combination : Max P{1}

Maximum creep rupture stress

Point : H06
Stress N/mm2 : 102
Allowable N/mm2 : 0 < See Note 1 >
Ratio : 0.00
Load combination : Sus.+T1{1}

□

CIRCUITOPROVABARRE

07/30/2010 CIRCUITO PROVA BARRE
BENTLEY

02:16 PM

AutoPIPE Plus 9.2.1 RESULT PAGE 123

R E S U L T S U M M A R Y

Maximum sustained stress ratio

Point : B02
Stress N/mm2 : 75
Allowable N/mm2 : 86
Ratio : 0.88
Load combination : GR + Max P{1}

Maximum displacement stress ratio

Point : B02
Stress N/mm2 : 57
Allowable N/mm2 : 197
Ratio : 0.29
Load combination : Max Range

Maximum occasional stress ratio

circuitprovabarre.txt

Point : H06
Stress N/mm2 : 96
Allowable N/mm2 : 219
Ratio : 0.44
Load combination : Hydrotest{1}

Maximum hoop stress ratio

Point : B06
Stress N/mm2 : 67
Allowable N/mm2 : 86
Ratio : 0.78
Load combination : Max P{1}

Maximum creep rupture stress ratio

Point : H06
Stress N/mm2 : 102
Allowable N/mm2 : 0 < See Note 1 >
Ratio : 0.00
Load combination : Sus.+T1{1}

* * * The system satisfies EN 13480 (2002) code requirements * * *
* * * for the selected options * * *

Warnings:

(1) Maximum creep rupture stress ratio is zero

* * * Note 1: Points were found in this stress category with * * *
* * * mechanical properties outside of temperature range. No * * *

□

CIRCUITOPROVABARRE

07/30/2010 CIRCUITO PROVA BARRE
BENTLEY

02:16 PM AutoPIPE Plus 9.2.1 RESULT PAGE 124

R E S U L T S U M M A R Y

* * * allowable stress were calculated at these points. * * *

□

Allegato 33:

Specifica tecnica e disegno candela del pressurizzatore

ELEMENTO SCALDANTE DEL PRESSURIZZATORE

Impianto: “Circuito Prova Barre”

Viene richiesta la fornitura di nr. 1 Elemento Scaldante (a riscaldamento indiretto per funzionamento ad immersione in acqua) dotato di Flangia saldata a tenuta.

Caratteristiche:

Le caratteristiche geometriche del pezzo sono presenti nel disegno allegato e qui riportate:

- Il valore di H, ovvero il tratto dell'elemento scaldante che esce dalla flangia può essere determinato in base alle esigenze costruttive ed alle problematiche relative alla temperatura d'esercizio; si consiglia un'altezza totale della barra di circa 4900 mm.
- La saldatura dell'elemento scaldante alla flangia deve garantire la tenuta idraulica e può essere realizzata nel modo più congeniale al costruttore, quindi non necessariamente nel punto indicato dal disegno allegato.
- Il diametro dell'elemento scaldante deve essere di 20 mm, in quanto deve essere inserito in un foro di 24.3 mm.
- La flangia da saldate deve essere una FLANGIA BLIND FORATA ANSI 2500 LM da 1”; il diametro del foro deve essere scelto in base al diametro dell'elemento scaldante in modo da garantire la tenuta idraulica
- L'elemento scaldante presenta una parte attiva di 1000 mm nella parte inferiore, mentre la restante altezza non deve generare potenza all'esterno
- In condizioni operative la parte attiva dell'elemento scaldante sarà sempre immersa in acqua satura; si prevede che la parte dell'elemento immersa nel liquido sia di 1533 mm. La restante parte sarà a contatto con una miscela di acqua/vapore d'acqua.
- È fondamentale che sia rispettato il posizionamento della flangia, la cui parte inferiore (codolo) deve essere a 4785 mm di altezza.
- È richiesta un sensore di temperatura annegato nel corpo o brasato sulla guaina a circa 2 cm dalla fine delle parte attiva come indicato dal disegno. Si desidera che la termocoppia misuri la temperatura dell'ossido.

Le condizioni operative previste sono:

- potenza elettrica totale 25 kW;
- collegamento elettrico trifase 400 Vac;
- lunghezza elemento attivo 1 m;
- pressione di progetto 172.5 bar;
- pressione di esercizio 155 bar;
- temperatura di progetto > 354°C;
- temperatura di esercizio 330°C;
- funzionamento discontinuo con transitori di pressione e di temperatura;
- gli elementi resistivi interni saranno alimentati a corrente alternata a parzializzazione di fase.

ELEMENTO SCALDANTE DEL PRESSURIZZATORE

Impianto: “Circuito Prova Barre”

Viene richiesta la fornitura di nr. 1 Elemento Scaldante (a riscaldamento indiretto per funzionamento ad immersione in acqua) dotato di Flangia saldata a tenuta.

Caratteristiche:

Le caratteristiche geometriche del pezzo sono presenti nel disegno allegato e qui riportate:

- Il valore di H, ovvero il tratto dell'elemento scaldante che esce dalla flangia può essere determinato in base alle esigenze costruttive ed alle problematiche relative alla temperatura d'esercizio; si consiglia un'altezza totale della barra di circa 4900 mm.
- La saldatura dell'elemento scaldante alla flangia deve garantire la tenuta idraulica e può essere realizzata nel modo più congeniale al costruttore, quindi non necessariamente nel punto indicato dal disegno allegato.
- Il diametro dell'elemento scaldante deve essere di 20 mm, in quanto deve essere inserito in un foro di 24.3 mm.
- La flangia da saldate deve essere una FLANGIA BLIND FORATA ANSI 2500 LM da 1"; il diametro del foro deve essere scelto in base al diametro dell'elemento scaldante in modo da garantire la tenuta idraulica
- L'elemento scaldante presenta una parte attiva di 1000 mm nella parte inferiore, mentre la restante altezza non deve generare potenza all'esterno
- In condizioni operative la parte attiva dell'elemento scaldante sarà sempre immersa in acqua satura; si prevede che la parte dell'elemento immersa nel liquido sia di 1533 mm. La restante parte sarà a contatto con una miscela di acqua/vapore d'acqua.
- È fondamentale che sia rispettato il posizionamento della flangia, la cui parte inferiore (codolo) deve essere a 4785 mm di altezza.
- È richiesta un sensore di temperatura annegato nel corpo o brasato sulla guaina a circa 2 cm dalla fine delle parte attiva come indicato dal disegno. Si desidera che la termocoppia misuri la temperatura dell'ossido.

Le condizioni operative previste sono:

- potenza elettrica totale 25 kW;
- collegamento elettrico trifase 400 Vac;
- lunghezza elemento attivo 1 m;
- pressione di progetto 172.5 bar;
- pressione di esercizio 155 bar;
- temperatura di progetto > 354°C;
- temperatura di esercizio 330°C;
- funzionamento discontinuo con transitori di pressione e di temperatura;
- gli elementi resistivi interni saranno alimentati a corrente alternata a parzializzazione di fase.

USCITA
TERMINAZIONI
ELETTRICHE

ESEGUIRE SALDATURA
A TENUTA TRA FLANGIA
E RESISTENZA

4782.7

4785

PRZ WATER
LEVEL

TERMOCOPPIA
TIPO K A GIUNTO ISOLATO

Lunghezza attiva
1000

Lunghezza attiva
1533

PRZ bottom

4	FLANGIA WN 1" ANSI 2500 LF	1	ASTM A182 F304	FORNITURA NON RICHIESTA
3	TERMOCOPPIA DI PARETE	1	DETTAGLI A CURA DEL COSTRUTTORE	
2	FLANGIA BLIND FORATA 1" ANSI 2500 LM	1	ASTM A182 F304	
1	RESISTENZA 25 KW Ø20 L_ATTIVA =1000 MM	1	H DA DEF. CAMICIA IN AISI 304	
POS.	DENOMINAZIONE	N° PEZZI	MATERIALE	NOTE
1				
0	24/02/'10		Greco, Congiu	
Rev.	Date	Modify	Dftm.	Controll. Approv.

		SPES3-IRIS circuito prova barre		
PIACENZA ITALY		Barra scaldante del pressurizzatore + flangia saldata + termocoppia		
Scale	Dwg code	File	General code	
1:10	HeaterPRZ	HeaterPRZ.dwg		

File name:

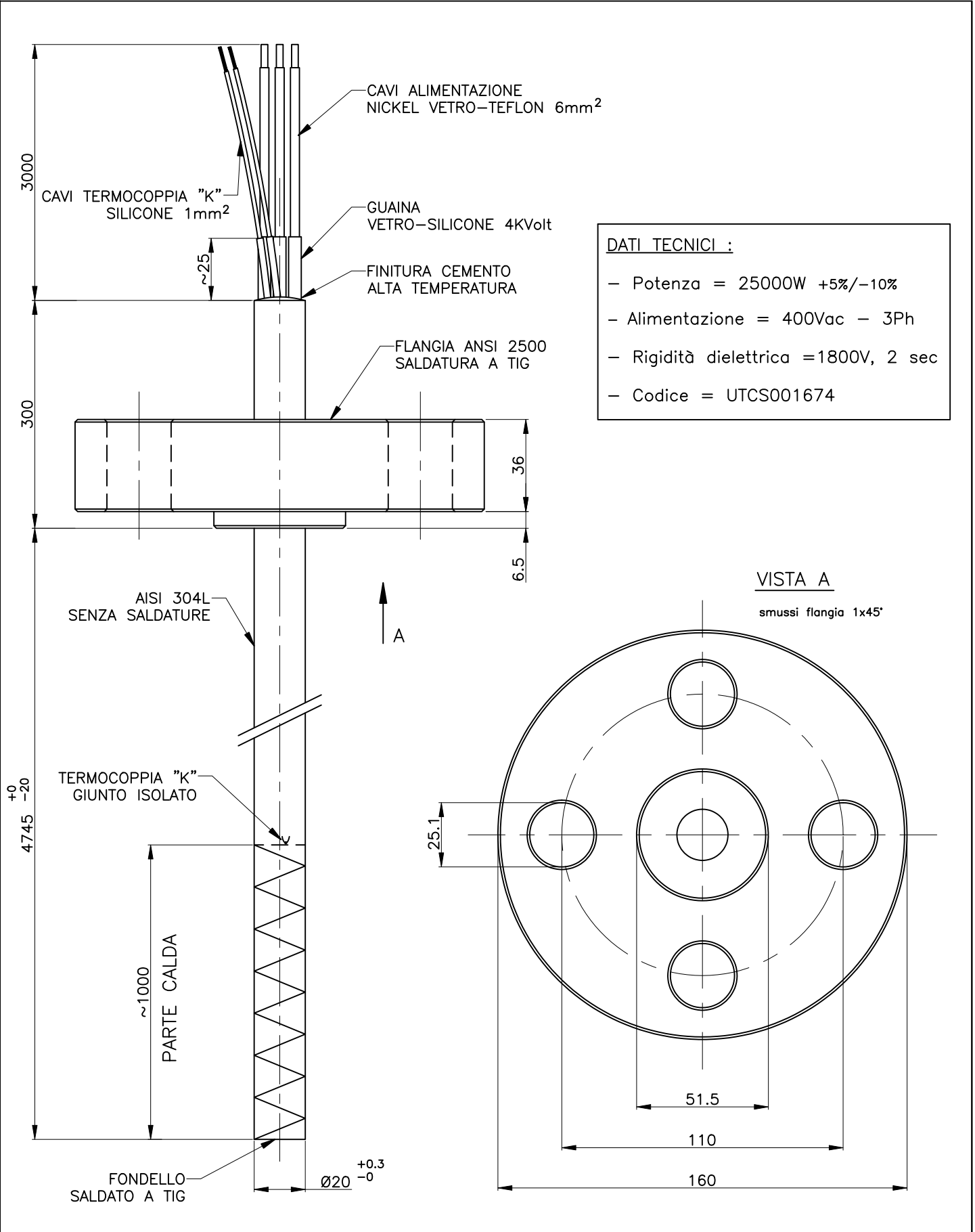

DATI TECNICI :

- Potenza = 25000W +5%/-10%
- Alimentazione = 400Vac - 3Ph
- Rigidità dielettrica = 1800V, 2 sec
- Codice = UTCS001674

VISTA A
smussi flangia 1x45°

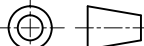
Disegnatore Drafted by M.DINICE	Controllato da Fabbr.	Checked by R. & S.	Nome file File name D100147-3	Rev. 3	Data Date 07/07/10	Scala Scale 1 : 2
 ROTIFIL s.r.l. Pianezza (TO) ITALY		Titolo Title CARTUCCIA UTC Ø20			Materiale Material	
		Disegno N. Drawing No. D100147	Cliente/Codice Customer/Part. No. SIET	RDR	Foglio Sheet 1/1	

Elenco disegni

074-00-00rev3:	Assieme generale
074-00-01rev3:	Dettagli (22 fogli)
074-00-02rev2:	Assieme inserito nella struttura (4 fogli)
074-01-00rev3:	Diagramma strumentato (2 fogli)
074-02-00rev3:	Schema di flusso (P&ID)

074-00-00rev3:

Assieme generale

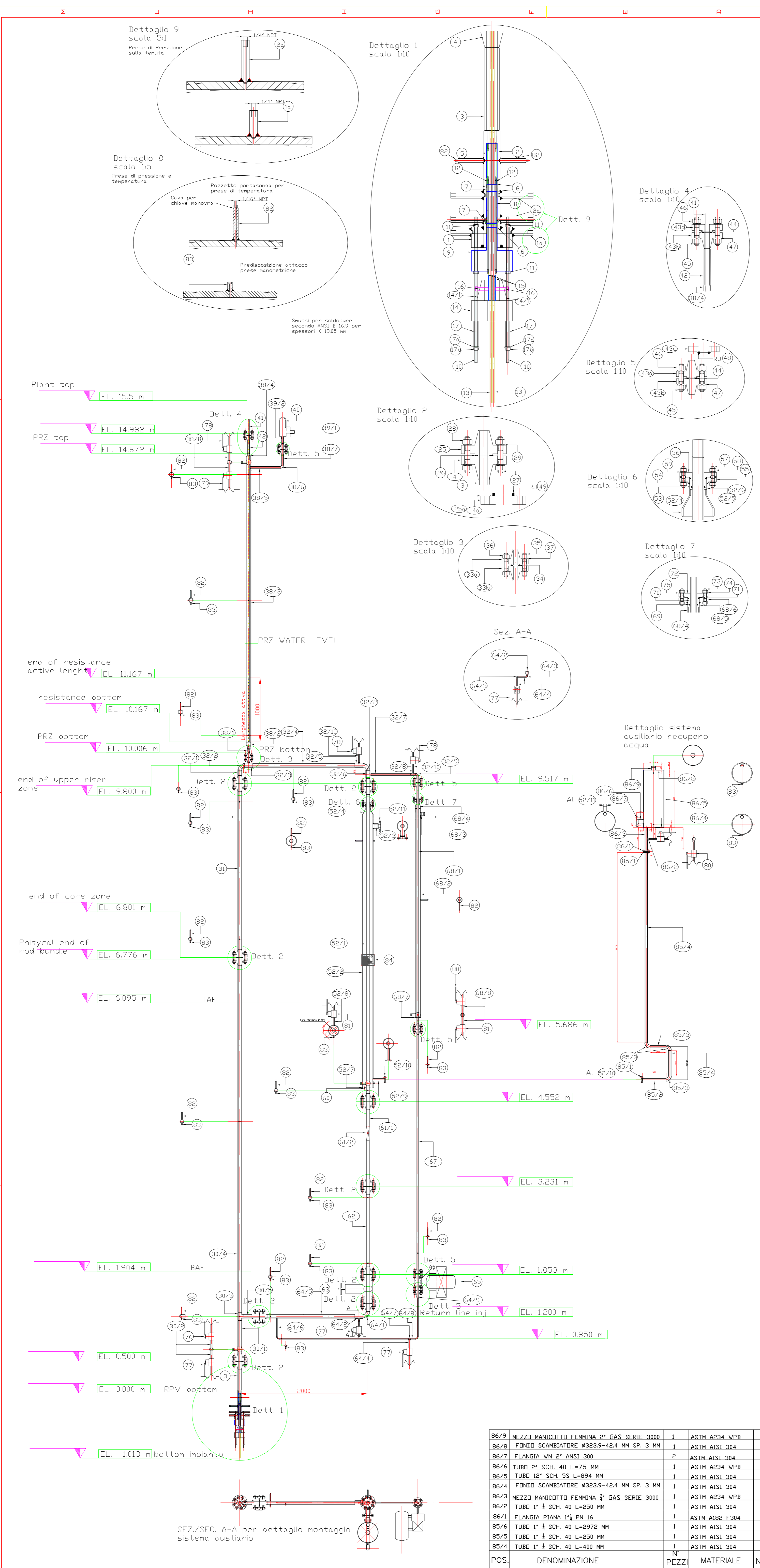

POS.	DENOMINAZIONE	N° PEZZI	MATERIALE	NOTE
85/3	CURVA LR 1 1/2 SCH 40	3	ASTM AISI 304	
85/2	TUBO 1" 1/2 SCH. 40 L=370 MM	1	ASTM A182 F304	
85/1	FLANGIA PIANA 1 1/2 PN 40	2	ASTM A182 F304	
84	TARGHETTA DI IDENTIFICAZIONE IMPIANTO	1	ASTM AISI 304	
83	TUBO PER PRESA MANOMETRICA (DETT.8)	19	ASTM AISI 304	
82	TUBO PORTASONDA TEMPERATURA (DETT.8)	18	ASTM AISI 304	
81	VALVOLA DI SCARICO 1/2 ANSI 300	2	ASTM AISI 304	
80	VALVOLA DI ALIMENTAZIONE 1/2 ANSI 300	2	ASTM AISI 304	
79	VALVOLA INIEZIONE AZOTO 1/2 ANSI 2500	1	ASTM AISI 304	
78	VALVOLA SFIATO 1/2 ANSI 2500	3	ASTM AISI 304	
77	VALVOLA DI SCARICO 1/2 ANSI 2500	3	ASTM AISI 304	
76	VALVOLA DI ALIMENTAZIONE 1/2 ANSI 2500	1	ASTM AISI 304	
75	ROSETTA A18 UNI1751	8	ASTM AISI 304	
74	DADD M18 UNISS588-65	8	ASTM A193 B8A	
73	PRIGIONIERO M18x110 UNIS909-66	4	ASTM A193 B7	
72	FLANGIA BLIND 2" FORATA Ø 34 MM ANSI 150	1	ASTM A182 F304	
71	GUARNIZIONE Ø92 / 60 SP. 4.4 MM	1	SPIRIDMETALLICA	
70	DISTANZIALE DA BARRA FORATA Ø50 / 32 H= 42.5 MM	1	ASTM AISI 304	
69	GUARNIZIONE BADERNA SEZ. QUADRA 6 MM	1	GOMMA	
68/8	TUBO 1/2" SCH.40 L= 125 MM	2	ASTM AISI 304	
68/7	FONDO SCAMBIATORE Ø88.9-33.4 MM SP. 8 MM	1	ASTM AISI 304	
68/6	FLANGIA SD 2" ANSI 150	1	ASTM AISI 304	
68/5	SEDE DA BARRA FORATA Ø63 / 32 H= 43.5 MM (DETT.7)	1	ASTM A182 F304	N°1 ITEM
68/4	RIDUZIONE CONCENTRICA 3" x 2" SCH.80	1	ASTM AISI 304	
68/3	MANICOTTO FEMMINA 1 1/2 GAS SERIE 3000	1	ASTM WP304	
68/2	TUBO 3" SCH.40 L= 3622 MM	1	ASTM AISI 304	
68/1	TUBO 1" SCH.80 L= 3672 MM	1	ASTM AISI 304	
67	TUBO 1" SCH.80 L= 3657 MM	1	ASTM WP304	
66	ORIFIZIO VALVOLA DI REGOLAZIONE 1"	1	ASTM AISI 304	
65	VALVOLA DI REGOLAZIONE 1" ANSI 2500	1	ASTM AISI 304	
64/9	RIDUZIONE CONCENTRICA SVAGE 1" x 1" XS	1	ASTM AISI 304	
64/8	TUBO 1/2" SCH.80 L= 725 MM	1	ASTM AISI 304	
64/7	TEE 1/2" SW S9000	1	ASTM WP304	
64/6	TUBO 1/2" SCH.80 L= 2368 MM	1	ASTM AISI 304	
64/5	TUBO 2" SCH.160 L= 1367 MM	1	ASTM AISI 304	
64/4	TUBO 1/2" SCH.80 L= 125 MM	3	ASTM AISI 304	
64/3	CURVA 90° LR 1/2" SCH.80	2	ASTM WP304	
64/2	TEE RIDOTTO SW 2"x1/2" S.6000	1	ASTM WP304	
64/1	CURVA 90° LR 2" SCH.160	1	ASTM WP304	
63	VALVOLA A SARACINESCA 2" ANSI 2500	1	ASTM AISI 304	
62	TUBO 2" SCH.160 L= 1132 MM	1	ASTM AISI 304	
61/2	VENTURIMETRO TUBO 2" BETA =0.4	1	ASTM AISI 304	
61/1	TUBO 2" SCH.160 L= 1069 MM	1	ASTM AISI 304	
60	TAPPO 1" GAS SERIE 3000	1	ASTM WP304	
59	ROSETTA A18 UNI1751	8	ASTM AISI 304	
58	DADD M18 UNISS588-65	8	ASTM A193 B8A	
57	PRIGIONIERO M18x110 UNIS909-66	4	ASTM A193 B7	
56	FLANGIA BLIND 3" FORATA Ø 61 MM ANSI 150	1	ASTM A182 F304	
55	GUARNIZIONE Ø127 / 89 SP. 4.4 MM	1	SPIRIDMETALLICA	
54	DISTANZIALE DA BARRA FORATA Ø75 / 60 H= 49 MM	1	ASTM AISI 304	
53	GUARNIZIONE BADERNA SEZ. QUADRA 6 MM	1	GOMMA	
52/11	FLANGIA WN 2" ANSI 300	1	ASTM A182 F304	
52/10	FLANGIA PIANA 1 1/2 PN 40	1	ASTM A182 F304	
52/9	TUBO 1 1/2" SCH.40 L= 180 MM	1	ASTM AISI 304	
52/8	TUBO 1/2" SCH.40 L= 125 MM	1	ASTM AISI 304	
52/7	FONDO SCAMBIATORE Ø168.3-60.3 MM SP. 15 MM	1	ASTM AISI 304	
52/6	FLANGIA SD 3" ANSI 150	1	ASTM A182 F304	
52/5	SEDE DA BARRA FORATA Ø90/56 H= 63 MM (DETT.6)	1	ASTM AISI 304	N°1 ITEM
52/4	RIDUZIONE CONCENTRICA 6" x 3" SCH.40	1	ASTM WP304	
52/3	MANICOTTO FEMMINA 2" GAS SERIE 3000	1	ASTM WP304	
52/2	TUBO 6" SCH.40 L= 4232.5 MM	1	ASTM AISI 304	
52/1	TUBO 2" SCH.160 L= 4667 MM	1	ASTM AISI 304	
49	GUARNIZIONE 2" RJ 2500LB Ø101.6 L 1111 H. 15.88 MM	2	SPIRIDMETALLICA	
48	GUARNIZIONE 1" RJ 1500LB Ø50.8 L 794 H. 12.7 MM	2	SPIRIDMETALLICA	
43a/b	FLANGIA WN 1" ANSI 2500 LM/LF (DETT.5)	2	ASTM A182 F304	N°3 ITEMS
47	ROSETTA A24 UNI1751	8	ASTM AISI 304	
46	DADD M24 UNISS588-65	8	ASTM A193 B8A	
45	PRIGIONIERO M24x150 UNIS909-66	4	ASTM AISI 304	
44	GUARNIZIONE Ø50 / 33 SP. 4.4 MM	1	SPIRIDMETALLICA	
43c	FLANGIA WN 1" ANSI2500 RJ (DETT.4)	2	ASTM A182 F304	N°1 ITEM
43a/d	FLANGIA WN 1" ANSI2500 LF/BL FURTO Ø=24.3 MM (DETT.4)	2	ASTM A182 F304	N°1 ITEM
42	TUBO 1" SCH.80 L= 190.5 MM	1	ASTM AISI 304	
41	RESISTENZA 25 KW Ø19.75 L=5000/1000 MM	1	CU	
40	FLANGIA WN 1 1/2 ANSI 2500 LF	1	ASTM A182 F304	
39	VALVOLA DI SICUREZZA ANSI 2500 1"X1 1/2	1	ASTM AISI 304	
38/8	TUBO 1/2" SCH.80 L= 125 MM	2	ASTM AISI 304	
38/7	TUBO 1" SCH.80 L= 216 MM	1	ASTM AISI 304	
38/6	CURVA 90° LR 1" SCH.80	1	ASTM WP304	
38/5	TUBO 1" SCH.80 L= 462 MM	1	ASTM AISI 304	
38/4	RIDUZIONE CONCENTRICA 2 1/2" x 1" SCH.160	1	ASTM WP304	
38/3	TUBO 2" SCH.160 L= 4429 MM	1	ASTM AISI 304	
38/2	RIDUZIONE CONCENTRICA 1 1/2" x 2 1/2" SCH.160	1	ASTM WP304	
38/1	RIDUZIONE CONCENTRICA 3 1/2" x 1" SCH.160	1	ASTM WP304	
37	ROSETTA A20 UNI1751	8	ASTM AISI 304	
36	DADD M20 UNISS588-65	8	ASTM A193 B8A	
35	PRIGIONIERO M20x130 UNIS909-66	4	ASTM A193 B7	
34	GUARNIZIONE Ø43/ 27 SP. 4.4 MM	1	SPIRIDMETALLICA	
33a/b	FLANGIA WN 3" ANSI 2500 LM/LF (DETT.3)	2	ASTM A182 F304	N°1 ITEM
32/10	TUBO 1/2" SCH.80 L= 125 MM	1	ASTM AISI 304	
32/9	CURVA 90° LR 1" SCH.80	1	ASTM WP304	
32/8	TEE RIDOTTO 1"x1/2" SCH.80	1	ASTM WP304	
32/7	TUBO 1" SCH.80 L= 526 MM	1	ASTM AISI 304	
32/6	TEE RIDOTTO 2"x1" SCH.160	1	ASTM WP304	
32/5	TEE RIDOTTO 2"x1/2" SCH.160	1	ASTM WP304	
32/4	TUBO 2" SCH.160 L= 1594 MM	1	ASTM AISI 304	
32/3	TEE RIDOTTO 2"x3/4" SCH.160	1	ASTM WP304	
32/2	CURVA 90° LR 2" SCH.160	2	ASTM WP304	
32/1	TUBO 2" SCH.160 L= 81 MM	1	ASTM AISI 304	
31	TUBO 2" SCH.160 L= 2463 MM	1	ASTM AISI 304	
30/5	TUBO 2" SCH.160 L= 113 MM	1	ASTM AISI 304	
30/4	TUBO 2" SCH.160 L= 5411 MM	1	ASTM AISI 304	
30/3	TEE 2" SCH.160	1	ASTM WP304	
30/2	TUBO 1/2" SCH.80 L= 125 MM	2	ASTM AISI 304	
30/1	TUBO 2" SCH.160 L= 510 MM	1	ASTM AISI 304	
29	ROSETTA A30 UNI1751	8	ASTM A182 F304	
28	DADD M30 UNISS588-65	8	ASTM A193 B8A	
27	PRIGIONIERO M30x195 UNIS909-66	4	ASTM A193 B7	
26	GUARNIZIONE Ø73/ 48 SP. 4.4 MM	1	SPIRIDMETALLICA	
25a	FLANGIA WN 2" ANSI 2500 RJ (DETT.2)	1	ASTM A182 F304	N°1 ITEM
25	FLANGIA WN 2" ANSI 2500 LM (DETT.2)	1	ASTM A182 F304	N°7 ITEM
24	DADD M6	4	ASTM A194 BB	
23	BARRA FORATA BEXT, 6INT L= 265.1 MM	4	ASTM AISI 304	
22	BARRA FORATA BEXT, 6INT L= 383.9 MM	4	ASTM AISI 304	
21	BARRA FORATA BEXT, 6INT L= 410.5 MM	44	ASTM AISI 304	
20	GRIGLIE DISTANZIATRICI	15	ASTM AISI 304	
19	BARRA FORATA BEXT, 6INT L= 730.5	8	ASTM AISI 304	
18	TIRANTE M6x6806	4	ASTM A193 B7	
17b	DADD M10	4	ASTM A194 BB	
17a	RONDELLA	4	ASTM AISI 304	
17	TUBO 1/2" SCH.160 L= 100 MM	4	ASTM AISI 304	
16	DADD M30	2	ASTM A194 BB	
15	COLTELLO DISTANZIATORE BARRE	3	ASTM AISI 304/Cu	
14/1	CUNEO SOSTEGNO BARRE	2	ASTM AISI 304	
14	FLANGIA SOSTEGNO BARRE (DETT.1) (MACHINED)	1	ASTM AISI 304	
13	BARRE DI POTENZA	4		CUSTOM
12	TIRANTE M5x380	2	ASTM A193 B7	
11	DADD M10	8	ASTM A194 BB	
10	TIRANTE M10x570	4	ASTM A193 B7	
9	FLANGIA DI CHIUSURA (DETT.1) (MACHINED)	1	ASTM AISI 304	N°1 ITEM
8	ANELLO TENUTA INTERNA	1	ASTM AISI 304	
7	GUARNIZIONE	3	GRAFITE	
6	RONDELLA ISOLANTE	4	ASTM AISI 304	
5	FLANGIA DI CENTRAGGIO	1	ASTM AISI 304	
4a	FLANGIA WN 2" ANSI 2500 RJ (DETT.2)	1	ASTM A182 F304	N°1 ITEM
4	FLANGIA WN 2" ANSI 2500 LF (DETT.2)	1	ASTM A182 F304	N°7 ITEM
3	TUBO 2" SCH.160 L= 324 MM	1	ASTM AISI 304	
2a	TUBO PER PRESA MANOMETRICA (DETT. 9)	4	ASTM AISI 304	
2	INVOLUCRO DA BARRA FORATA Ø63/36 H=457MM	1	ASTM AISI 304	
1a	TUBO PER PRESA MANOMETRICA (DETT. 9)	2	ASTM AISI 304	MACHINED
1	FLANGIA INFERIORE RPV	1	ASTM AISI 304	MACHINED

Rev.	Date	Modify	Dftn.	Controll.	Approv.
3	01/07/10	Modifiche "as built"			Congliu
2	05/03/10	Particolari 5,18,19,52/3,68/3 modificati			Tortora
1	18/12/09	ISSUE			Greca,Tortora
0	15/09/09	DRAFT_B			Greco
0	27/05/09	DRAFT_A			Congliu

POS.	DENOMINAZIONE	N° PEZZI	MATERIALE	NOTE
86/9	MEZZO MANICOTTO FEMMINA 2" GAS SERIE 3000	1	ASTM A234 WPB	
86/8	FONDO SCAMBIATORE Ø323.9-42.4 MM SP. 3 MM	1	ASTM AISI 304	
86/7	FLANGIA WN 2" ANSI 300	2	ASTM AISI 304	
86/6	TUBO 2" SCH. 40 L=75 MM	1	ASTM A234 WPB	
86/5	TUBO 12" SCH. 5S L=894 MM	1	ASTM AISI 304	
86/4	FONDO SCAMBIATORE Ø323.9-42.4 MM SP. 3 MM	1	ASTM AISI 304	
86/3	MEZZO MANICOTTO FEMMINA 3" GAS SERIE 3000	1	ASTM A234 WPB	
86/2	TUBO 1" 1/2 SCH. 40 L=250 MM	1	ASTM AISI 304	
86/1	FLANGIA PIANA 1 1/2 PN 16	1	ASTM A182 F304	
85/6	TUBO 1" 1/2 SCH. 40 L=2972 MM	1	ASTM AISI 304	
85/5	TUBO 1" 1/2 SCH. 40 L=250 MM	1	ASTM AISI 304	
85/4	TUBO 1" 1/2 SCH. 40 L=400 MM	1	ASTM AISI 304	

OSIET
PIACENZA
ITALY

Scale: 1:30
 Dwg code: 074.00.00
 File: 074.00.00 rev3.dwg
 General code:

SPES3-IRIS circuito prova barre
 Assieme generale

074-00-01rev3:

Dettagli (22 fogli)

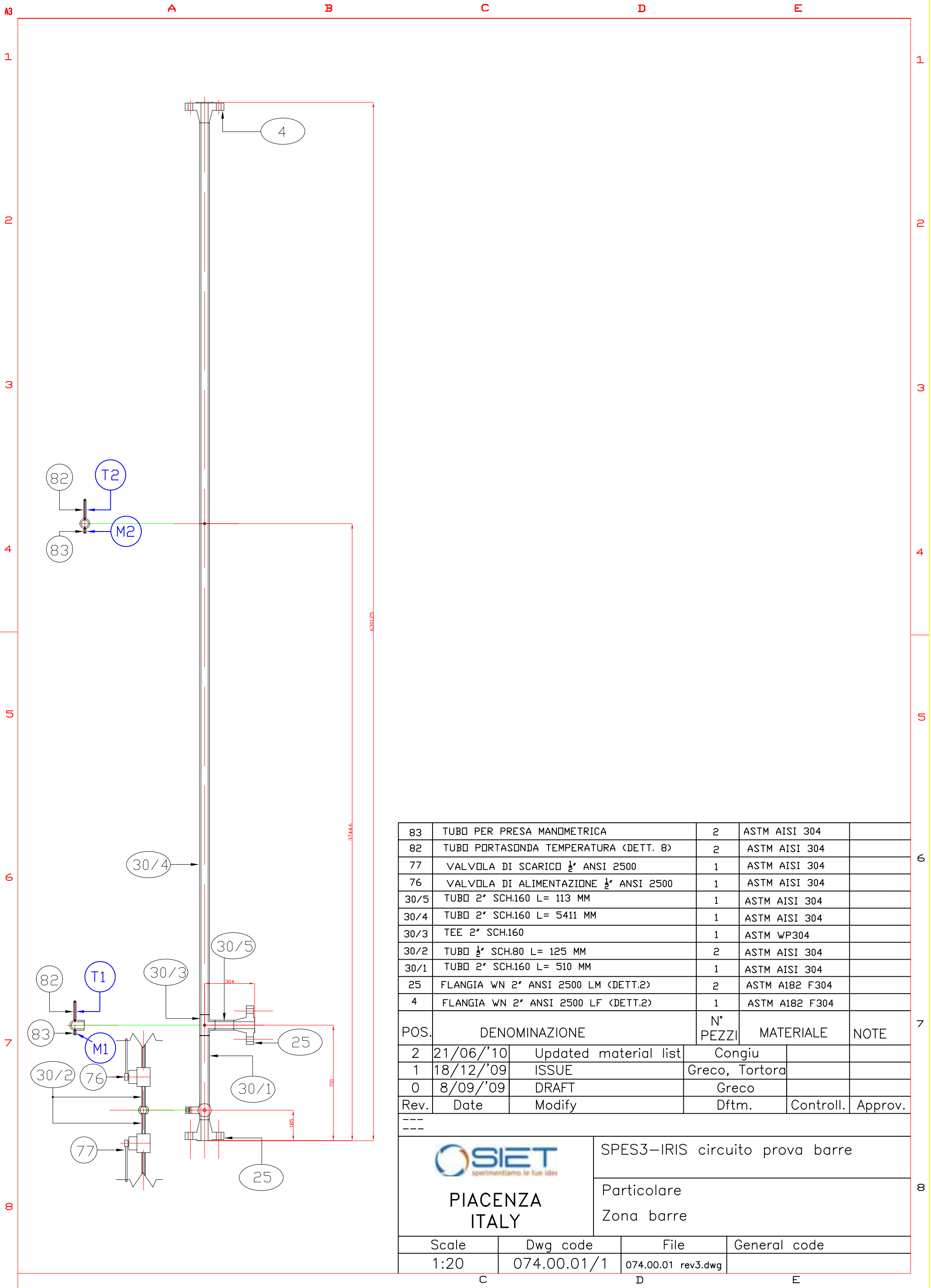

83	TUBO PER PRESA MANOMETRICA	2	ASTM AISI 304	
82	TUBO PORTASONDA TEMPERATURA (DETT. 8)	2	ASTM AISI 304	
77	VALVOLA DI SCARICO 1/2" ANSI 2500	1	ASTM AISI 304	
76	VALVOLA DI ALIMENTAZIONE 1/2" ANSI 2500	1	ASTM AISI 304	
30/5	TUBO 2" SCH.160 L= 113 MM	1	ASTM AISI 304	
30/4	TUBO 2" SCH.160 L= 5411 MM	1	ASTM AISI 304	
30/3	TEE 2" SCH.160	1	ASTM WP304	
30/2	TUBO 1/2" SCH.80 L= 125 MM	2	ASTM AISI 304	
30/1	TUBO 2" SCH.160 L= 510 MM	1	ASTM AISI 304	
25	FLANGIA WN 2" ANSI 2500 LM (DETT.2)	2	ASTM A182 F304	
4	FLANGIA WN 2" ANSI 2500 LF (DETT.2)	1	ASTM A182 F304	

POS.	DENOMINAZIONE	N° PEZZI	MATERIALE	NOTE
2	21/06/'10 Updated material list		Congiu	
1	18/12/'09 ISSUE		Greco, Tortora	
0	8/09/'09 DRAFT		Greco	
Rev.	Date	Modify	Dftm.	Controll. Approv.

 PIACENZA ITALY	SPES3-IRIS circuito prova barre		
	Particolare Zona barre		
Scale	Dwg code	File	General code
1:20	074.00.01/1	074.00.01 rev3.dwg	

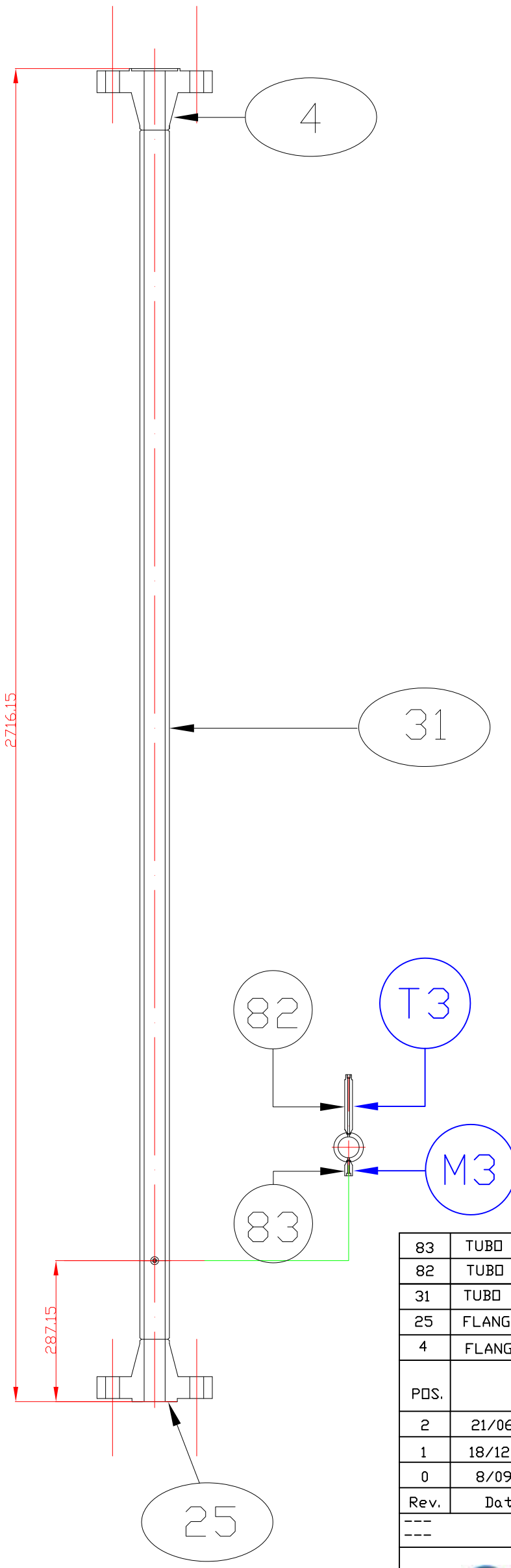

83	TUBO PER PRESA MANDOMETRICA	1	ASTM AISI 304	
82	TUBO PORTASONDA TEMPERATURA <DETT. 8>	1	ASTM AISI 304	
31	TUBO 2" SCH.160 L= 2463 MM	1	ASTM AISI 304	
25	FLANGIA WN 2" ANSI 2500 LM <DETT.2>	1	ASTM A182 F304	
4	FLANGIA WN 2" ANSI 2500 LF <DETT.2>	1	ASTM A182 F304	

PDS.	DENOMINAZIONE		N° PEZZI	MATERIALE	NOTE
2	21/06/'10	Updated material list	Congiu		
1	18/12/'09	ISSUE	Greco, Tortora		
0	8/09/'09	DRAFT	Greco		
Rev.	Date	Modify	Dftm.	Controll.	Approv.

 PIACENZA ITALY	SPES3-IRIS circuito prova barre		
	Particolare Tratto uscita zona barre		
Scale	Dwg code	File	General code
1:10	074.00.01/2	074.00.01 rev3.dwg	

File name:

A B C D E

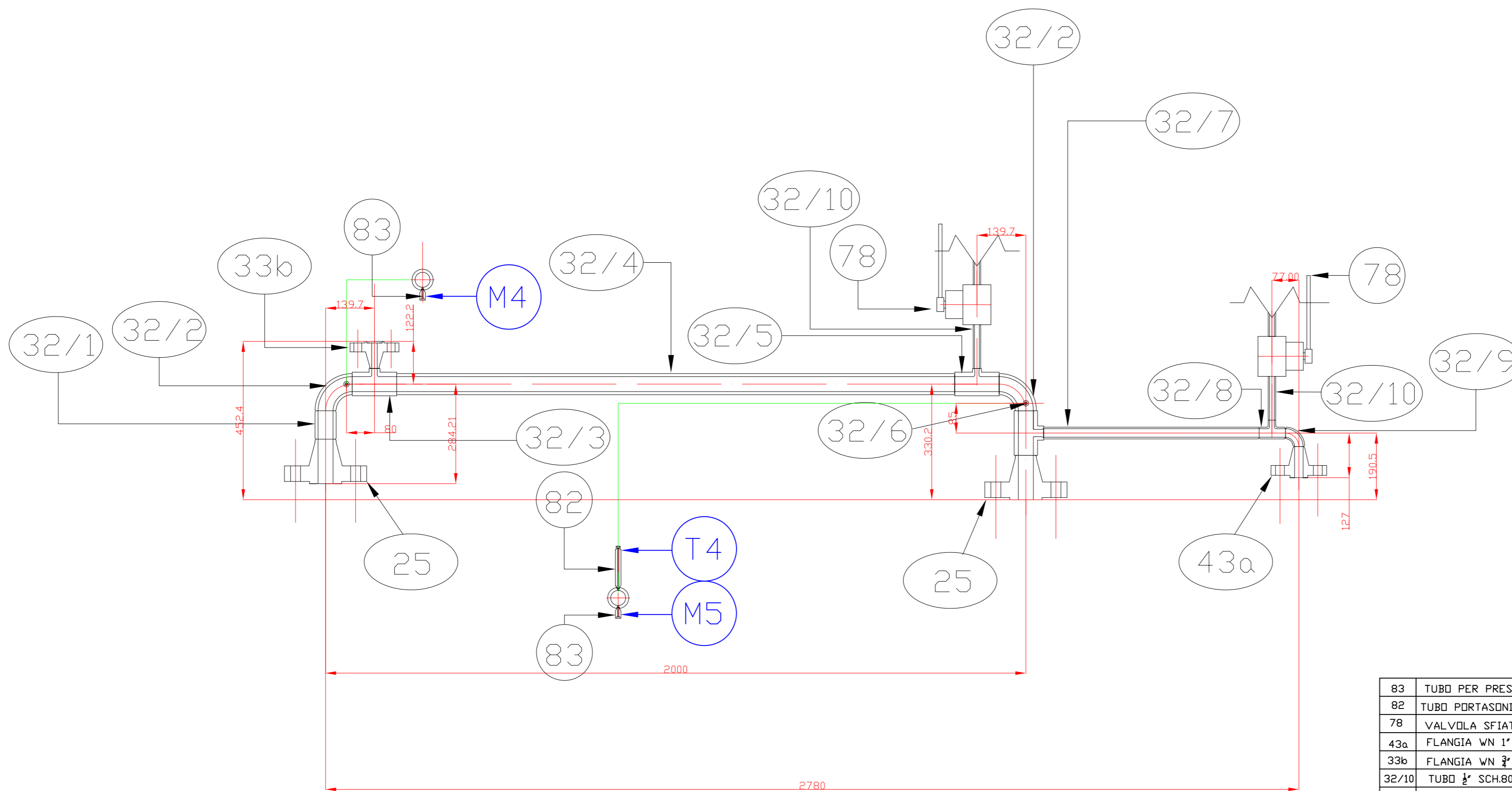

83	TUBO PER PRESA MANOMETRICA	2	ASTM AISI 304	
82	TUBO PORTASONDA TEMPERATURA (DETT.8)	1	ASTM AISI 304	
78	VALVOLA SFIATO 1/2" ANSI 2500	2	ASTM AISI 304	
43a	FLANGIA WN 1" ANSI 2500 LM (DETT.5)	1	ASTM A182 F304	
33b	FLANGIA WN 3/4" ANSI 2500 LF (DETT.3)	1	ASTM A182 F304	
32/10	TUBO 1/2" SCH.80 L= 125 MM	1	ASTM AISI 304	
32/9	CURVA 90° LR 1" SCH.80	1	ASTM WP304	
32/8	TEE RIDOTTO 1"x1/2" sch. 80	1	ASTM WP304	
32/7	TUBO 1" SCH.80 L= 526 MM	1	ASTM AISI 304	
32/6	TEE RIDOTTO 2"x1" SW SERIE 6000	1	ASTM WP304	
32/5	TEE RIDOTTO 2"x1/2" SW SERIE 6000	1	ASTM WP304	
32/4	TUBO 2" SCH.160 L= 1594 MM	1	ASTM AISI 304	
32/3	TEE RIDOTTO 2"x3/4" SW SERIE 6000	1	ASTM WP304	
32/2	CURVA 90° LR 2" SCH.160	2	ASTM WP304	
32/1	TUBO 2" SCH.160 L= 81 MM	1	ASTM AISI 304	
25	FLANGIA WN 2" ANSI 2500 LM (DETT.2)	2	ASTM A182 F304	N°8 ITEM

PDS.	DENOMINAZIONE	N° PEZZI	MATERIALE	NOTE
2	25/06/'10 Updated material list,P&T pos		Conglu	
1	18/12/'09 ISSUE		Greco, Tortora	
0	8/09/'09 DRAFT		Greco	
Rev.	Date	Modify	Dftm.	Controll.
---				Approv.

 PIACENZA ITALY	SPES3-IRIS circuito prova barre		
	Particolare Tratto orizzontale superiore		
Scale	Dwg code	File	General code
1:10	074.00.01/3	074.00.01 rev3.dwg	

File name: A2

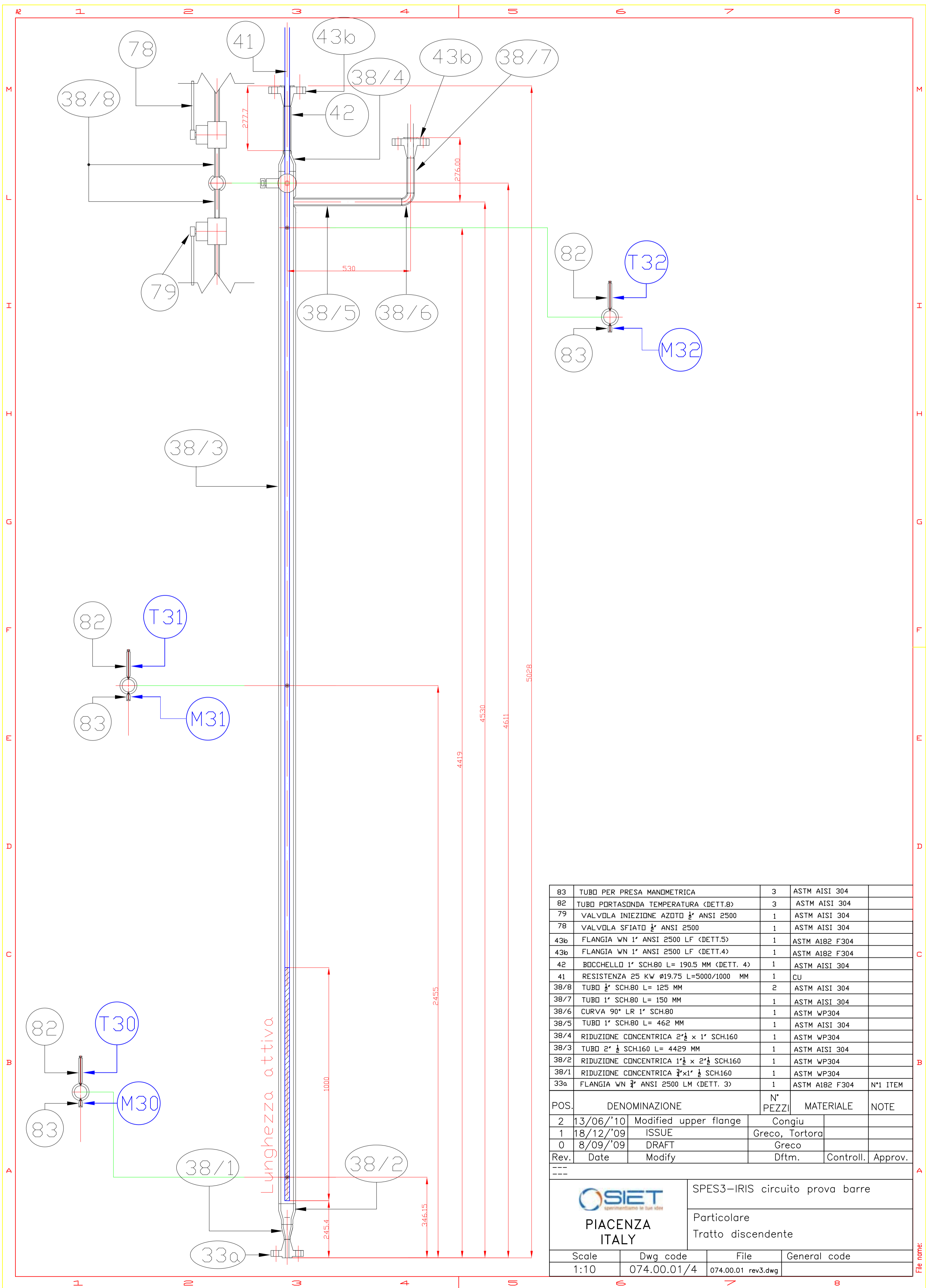

83	TUBO PER PRESA MANOMETRICA	3	ASTM AISI 304	
82	TUBO PORTASONDA TEMPERATURA (DETT.8)	3	ASTM AISI 304	
79	VALVOLA INIEZIONE AZOTO 1/2" ANSI 2500	1	ASTM AISI 304	
78	VALVOLA SFIATO 1/2" ANSI 2500	1	ASTM AISI 304	
43b	FLANGIA WN 1" ANSI 2500 LF (DETT.5)	1	ASTM A182 F304	
43b	FLANGIA WN 1" ANSI 2500 LF (DETT.4)	1	ASTM A182 F304	
42	BUCCELLO 1" SCH.80 L= 190.5 MM (DETT. 4)	1	ASTM AISI 304	
41	RESISTENZA 25 KW Ø19.75 L=5000/1000 MM	1	CU	
38/8	TUBO 1/2" SCH.80 L= 125 MM	2	ASTM AISI 304	
38/7	TUBO 1" SCH.80 L= 150 MM	1	ASTM AISI 304	
38/6	CURVA 90° LR 1" SCH.80	1	ASTM WP304	
38/5	TUBO 1" SCH.80 L= 462 MM	1	ASTM AISI 304	
38/4	RIDUZIONE CONCENTRICA 2" x 1" SCH.160	1	ASTM WP304	
38/3	TUBO 2" x 1" SCH.160 L= 4429 MM	1	ASTM AISI 304	
38/2	RIDUZIONE CONCENTRICA 1" x 2" x 1" SCH.160	1	ASTM WP304	
38/1	RIDUZIONE CONCENTRICA 3" x 1" x 1" SCH.160	1	ASTM WP304	
33a	FLANGIA WN 3" ANSI 2500 LM (DETT. 3)	1	ASTM A182 F304	N*1 ITEM

POS.	DENOMINAZIONE	N° PEZZI	MATERIALE	NOTE
2	13/06/'10 Modified upper flange		Congiu	
1	18/12/'09 ISSUE		Greco, Tortora	
0	8/09/'09 DRAFT		Greco	
Rev.	Date	Modify	Dftm.	Controll. Approv.

 PIACENZA ITALY	SPES3-IRIS circuito prova barre		
	Particolare Tratto discendente		
Scale	Dwg code	File	General code
1:10	074.00.01/4	074.00.01 rev3.dwg	

File name:

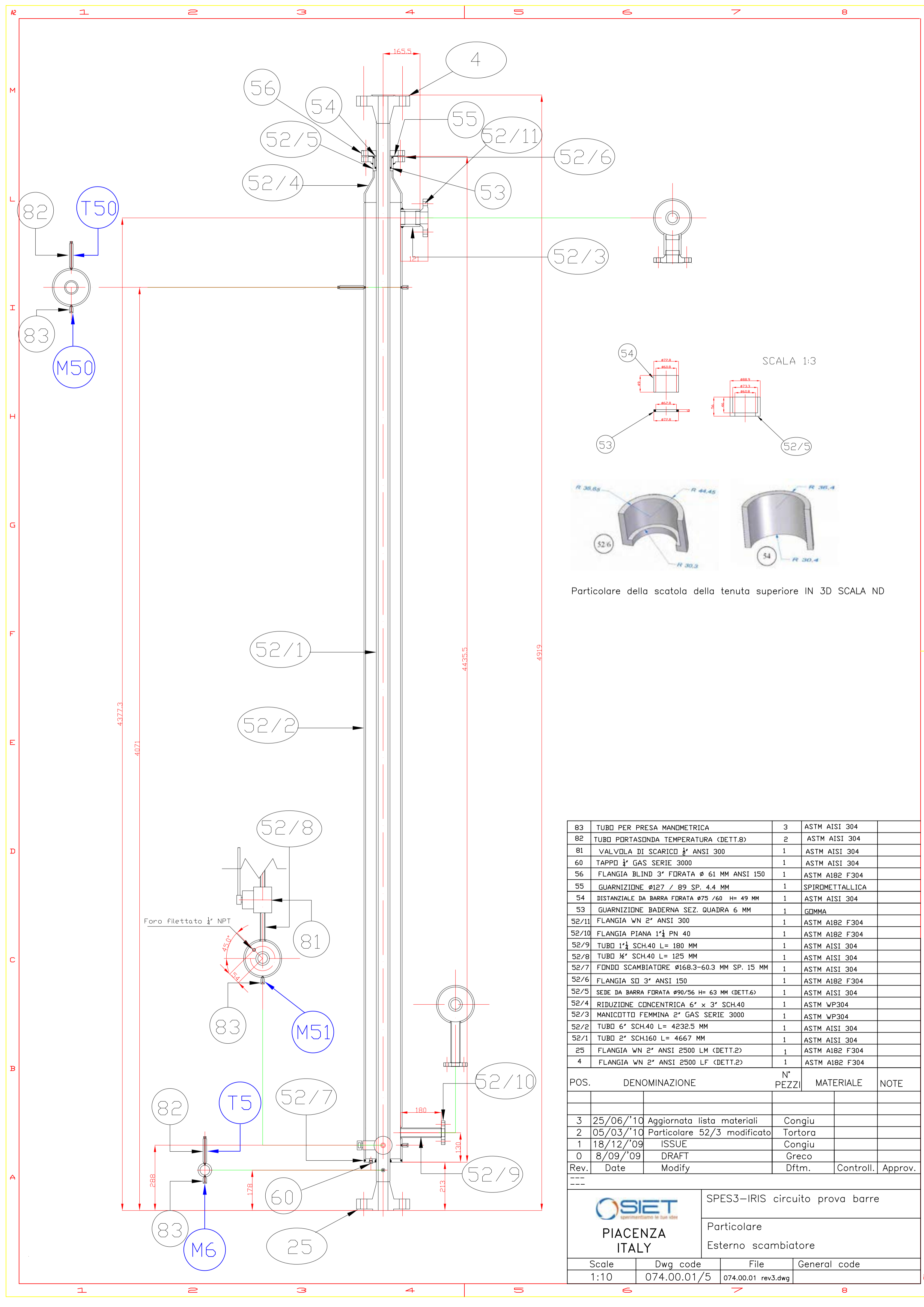

83	TUBO PER PRESA MANOMETRICA	3	ASTM AISI 304	
82	TUBO PORTASONDA TEMPERATURA (DETT.8)	2	ASTM AISI 304	
81	VALVOLA DI SCARICO 1/2" ANSI 300	1	ASTM AISI 304	
60	TAPPO 1/2" GAS SERIE 3000	1	ASTM AISI 304	
56	FLANGIA BLIND 3" FORATA Ø 61 MM ANSI 150	1	ASTM A182 F304	
55	GUARNIZIONE Ø127 / 89 SP. 4.4 MM	1	SPIROMETALLICA	
54	DISTANZIALE DA BARRA FORATA Ø75 / 60 H= 49 MM	1	ASTM AISI 304	
53	GUARNIZIONE BADERNA SEZ. QUADRA 6 MM	1	GOMMA	
52/11	FLANGIA WN 2" ANSI 300	1	ASTM A182 F304	
52/10	FLANGIA PIANA 1 1/4" PN 40	1	ASTM A182 F304	
52/9	TUBO 1 1/4" SCH.40 L= 180 MM	1	ASTM AISI 304	
52/8	TUBO 1/2" SCH.40 L= 125 MM	1	ASTM AISI 304	
52/7	FONDO SCAMBIATORE Ø168.3-60.3 MM SP. 15 MM	1	ASTM AISI 304	
52/6	FLANGIA SD 3" ANSI 150	1	ASTM A182 F304	
52/5	SEDE DA BARRA FORATA Ø90/56 H= 63 MM (DETT.6)	1	ASTM AISI 304	
52/4	RIDUZIONE CONCENTRICA 6" x 3" SCH.40	1	ASTM WP304	
52/3	MANICOTTO FEMMINA 2" GAS SERIE 3000	1	ASTM WP304	
52/2	TUBO 6" SCH.40 L= 4232.5 MM	1	ASTM AISI 304	
52/1	TUBO 2" SCH.160 L= 4667 MM	1	ASTM AISI 304	
25	FLANGIA WN 2" ANSI 2500 LM (DETT.2)	1	ASTM A182 F304	
4	FLANGIA WN 2" ANSI 2500 LF (DETT.2)	1	ASTM A182 F304	

POS.	DENOMINAZIONE	N° PEZZI	MATERIALE	NOTE
3	25/06/'10	Aggiornata lista materiali	Congiu	
2	05/03/'10	Particolare 52/3 modificato	Tortora	
1	18/12/'09	ISSUE	Congiu	
0	8/09/'09	DRAFT	Greco	
Rev.	Date	Modify	Dftm.	Controll. Approv.
---	---	---	---	---

OSIET
 Specializzato in sua idea

PIACENZA ITALY

SPES3-IRIS circuito prova barre
 Particolare
 Esterno scambiatore

Scale	Dwg code	File	General code
1:10	074.00.01/5	074.00.01 rev3.dwg	

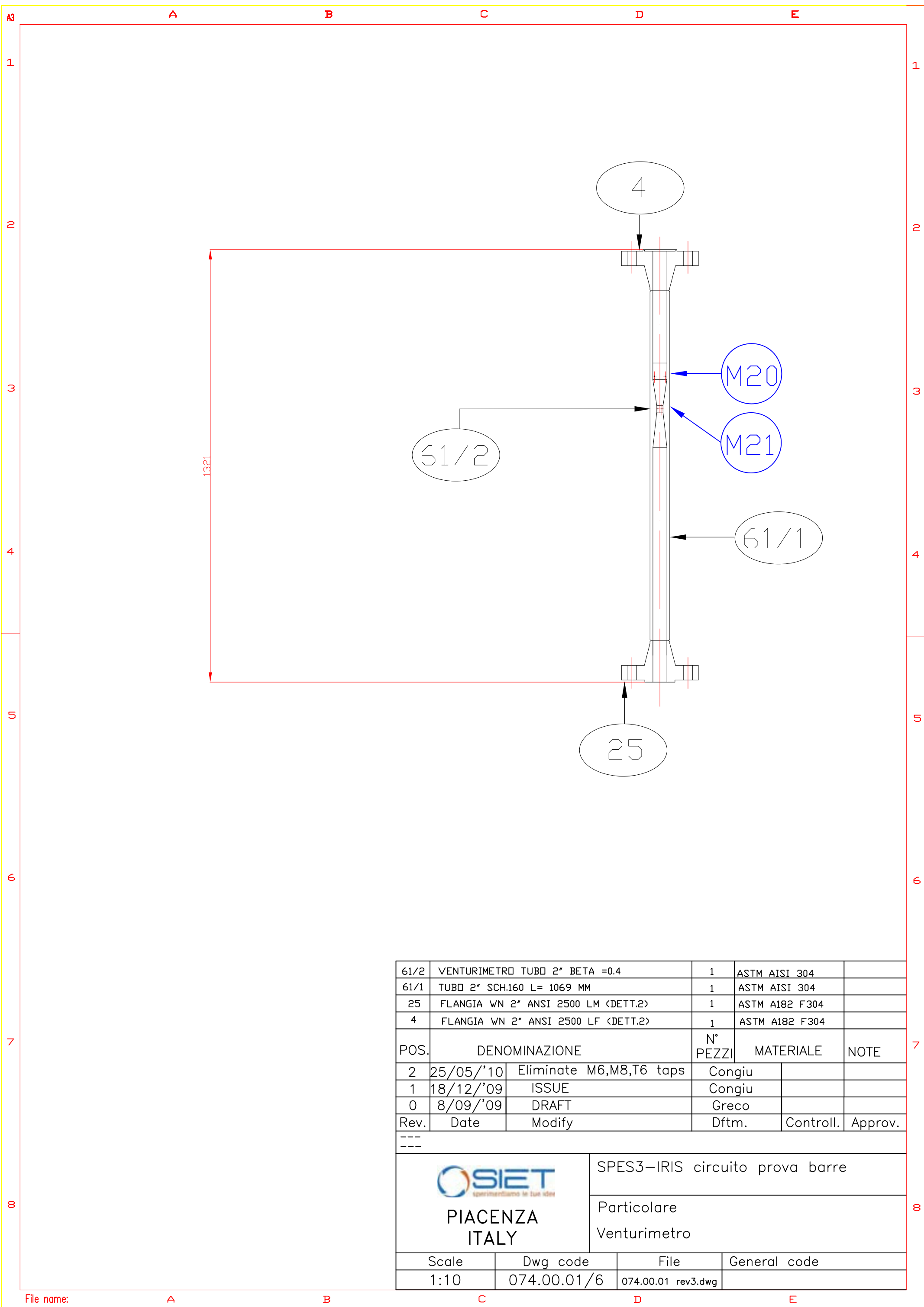

61/2	VENTURIMETRO TUBO 2" BETA =0.4	1	ASTM AISI 304	
61/1	TUBO 2" SCH.160 L= 1069 MM	1	ASTM AISI 304	
25	FLANGIA WN 2" ANSI 2500 LM (DETT.2)	1	ASTM A182 F304	
4	FLANGIA WN 2" ANSI 2500 LF (DETT.2)	1	ASTM A182 F304	
POS.	DENOMINAZIONE	N° PEZZI	MATERIALE	NOTE
2	25/05/'10 Eliminate M6,M8,T6 taps	Congiu		
1	18/12/'09 ISSUE	Congiu		
0	8/09/'09 DRAFT	Greco		
Rev.	Date	Modify	Dftm.	Controll. Approv.

 PIACENZA ITALY		SPES3-IRIS circuito prova barre		
		Particolare Venturimetro		
Scale	Dwg code	File	General code	
1:10	074.00.01/6	074.00.01 rev3.dwg		

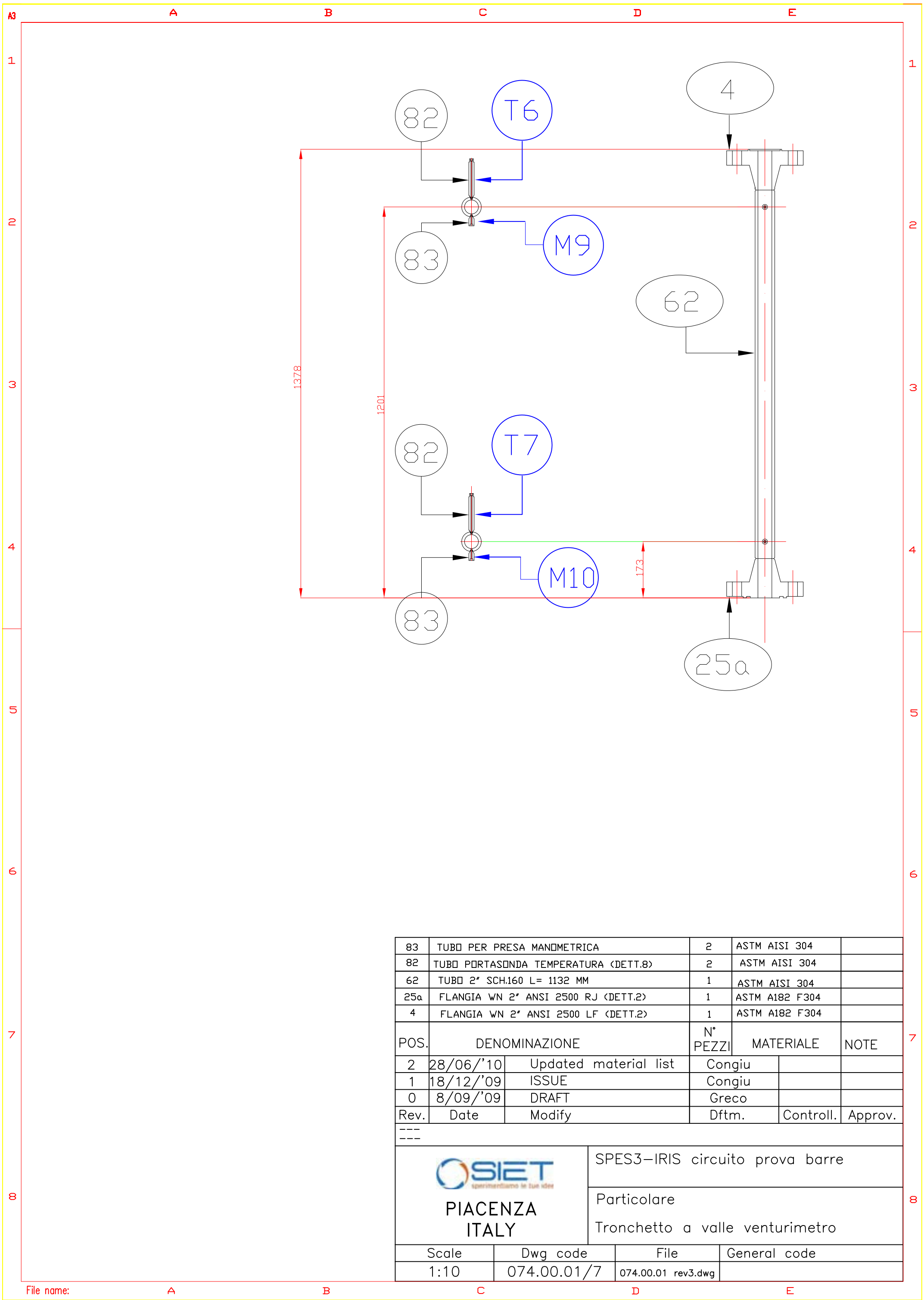

83	TUBO PER PRESA MANOMETRICA	2	ASTM AISI 304	
82	TUBO PORTASONDA TEMPERATURA (DETT.8)	2	ASTM AISI 304	
62	TUBO 2" SCH.160 L= 1132 MM	1	ASTM AISI 304	
25a	FLANGIA WN 2" ANSI 2500 RJ (DETT.2)	1	ASTM A182 F304	
4	FLANGIA WN 2" ANSI 2500 LF (DETT.2)	1	ASTM A182 F304	

POS.	DENOMINAZIONE		N° PEZZI	MATERIALE	NOTE
2	28/06/'10	Updated material list	Congiu		
1	18/12/'09	ISSUE	Congiu		
0	8/09/'09	DRAFT	Greco		
Rev.	Date	Modify	Dftm.	Controll.	Approv.

 PIACENZA ITALY	SPES3-IRIS circuito prova barre		
	Particolare Tronchetto a valle venturimetro		
Scale	Dwg code	File	General code
1:10	074.00.01/7	074.00.01 rev3.dwg	

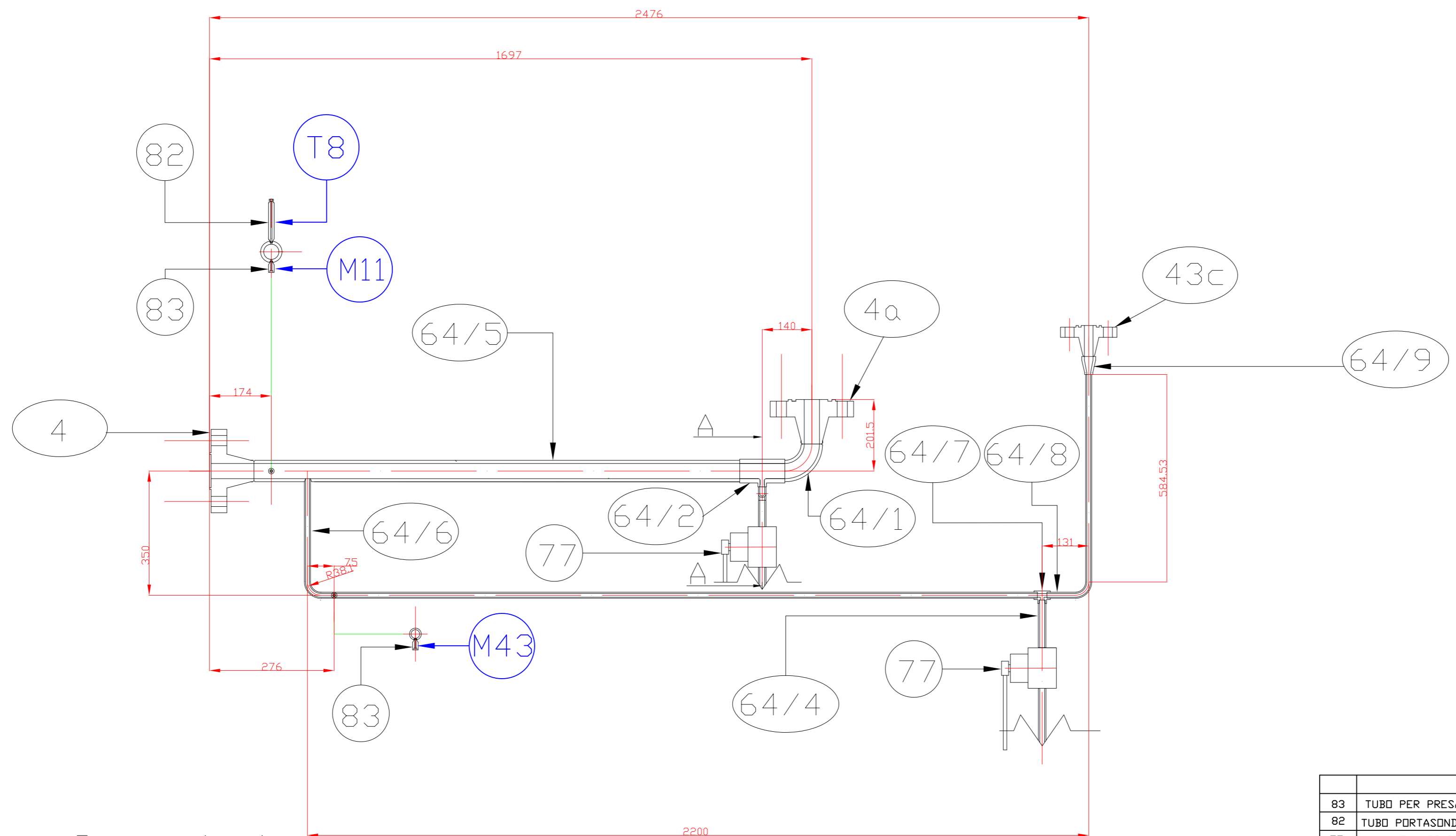

Sez. A-A

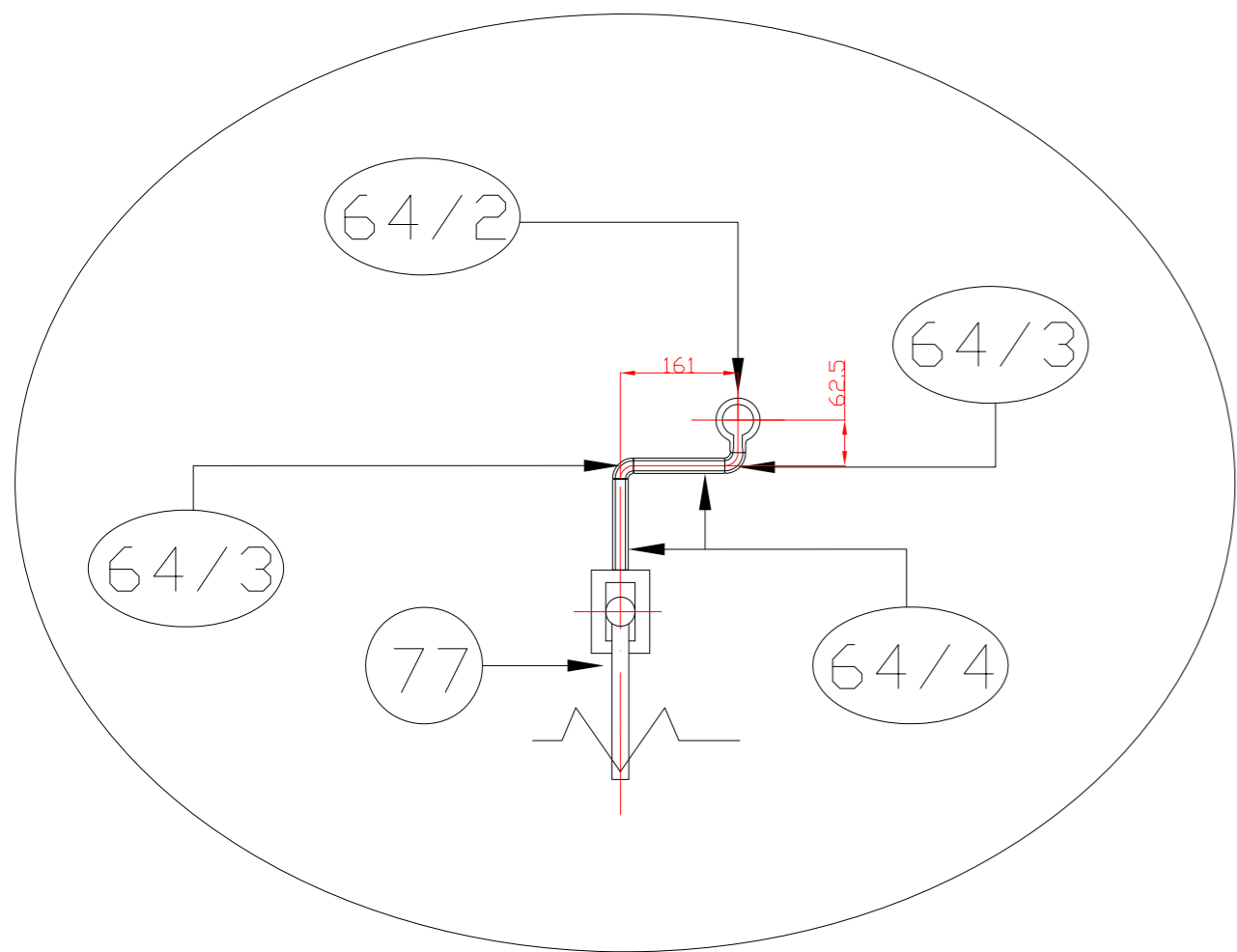

83	TUBO PER PRESA MANOMETRICA	2	ASTM AISI 304	
82	TUBO PORTASONDA TEMPERATURA (DETT.8)	1	ASTM AISI 304	
77	VALVOLA DI SCARICO 1/2" ANSI 2500	2	ASTM AISI 304	
64/9	RIDUZIONE CONCENTRICA SWAGE 3/4" x 1" XS	1	ASTM AISI 304	
64/8	TUBO 3/4" SCH.80 L= 725 MM	1	ASTM AISI 304	
64/7	TEE 3/4" SW S3000	1	ASTM WP304	
64/6	TUBO 3/4" SCH.80 L= 2368 MM	1	ASTM AISI 304	
64/5	TUBO 2" SCH.160 L= 1367 MM	1	ASTM AISI 304	
64/4	TUBO 1/2" SCH.80 L= 125 MM	3	ASTM AISI 304	
64/3	CURVA 90° LR 1/2" SCH.80	2	ASTM WP304	
64/2	TEE RIDOTTO SW 2"x1/2" S.6000	1	ASTM WP304	
64/1	CURVA 90° LR 2" SCH.160	1	ASTM WP304	
43c	FLANGIA WN 1" ANSI 1500 RJ (DETT.5)	1	ASTM A182 F304	
4a	FLANGIA WN 2" ANSI 2500 RJ (DETT.2)	1	ASTM A182 F304	
4	FLANGIA WN 2" ANSI 2500 LF (DETT.2)	1	ASTM A182 F304	
POS.	DENOMINAZIONE	N° PEZZI	MATERIALE	NOTE
2	28/06/'10 Updated material list	Congiu		
1	18/12/'09 ISSUE	Greco, Tortora		
0	8/09/'09 DRAFT	Greco		
Rev.	Date	Modify	Dftm.	Controll. Approv.

		SPES3-IRIS circuito prova barre		
PIACENZA ITALY		Particolare Tratto orizzontale inferiore		
Scale	Dwg code	File	General code	
1:10	074.00.01/8	074.00.01 rev3.dwg		

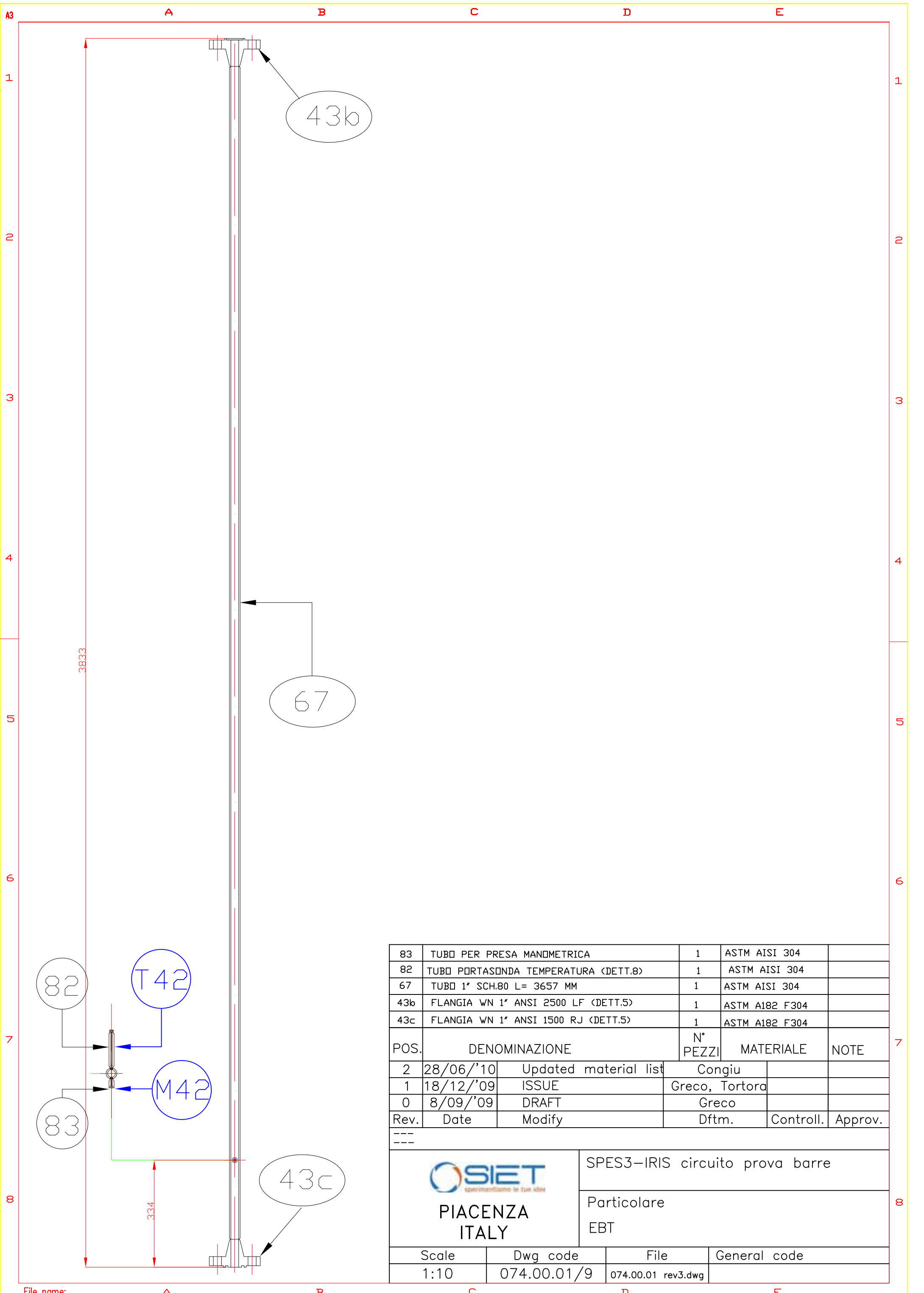

83	TUBO PER PRESA MANOMETRICA	1	ASTM AISI 304	
82	TUBO PORTASONDA TEMPERATURA (DETT.8)	1	ASTM AISI 304	
67	TUBO 1" SCH.80 L= 3657 MM	1	ASTM AISI 304	
43b	FLANGIA WN 1" ANSI 2500 LF (DETT.5)	1	ASTM A182 F304	
43c	FLANGIA WN 1" ANSI 1500 RJ (DETT.5)	1	ASTM A182 F304	
POS.	DENOMINAZIONE	N° PEZZI	MATERIALE	NOTE
2	28/06/'10 Updated material list	Congiu		
1	18/12/'09 ISSUE	Greco, Tortora		
0	8/09/'09 DRAFT	Greco		
Rev.	Date	Modify	Dftm.	Controll. Approv.

 PIACENZA ITALY		SPES3-IRIS circuito prova barre Particolare EBT		
Scale	Dwg code	File	General code	
1:10	074.00.01/9	074.00.01 rev3.dwg		

File name:

A

B

C

D

E

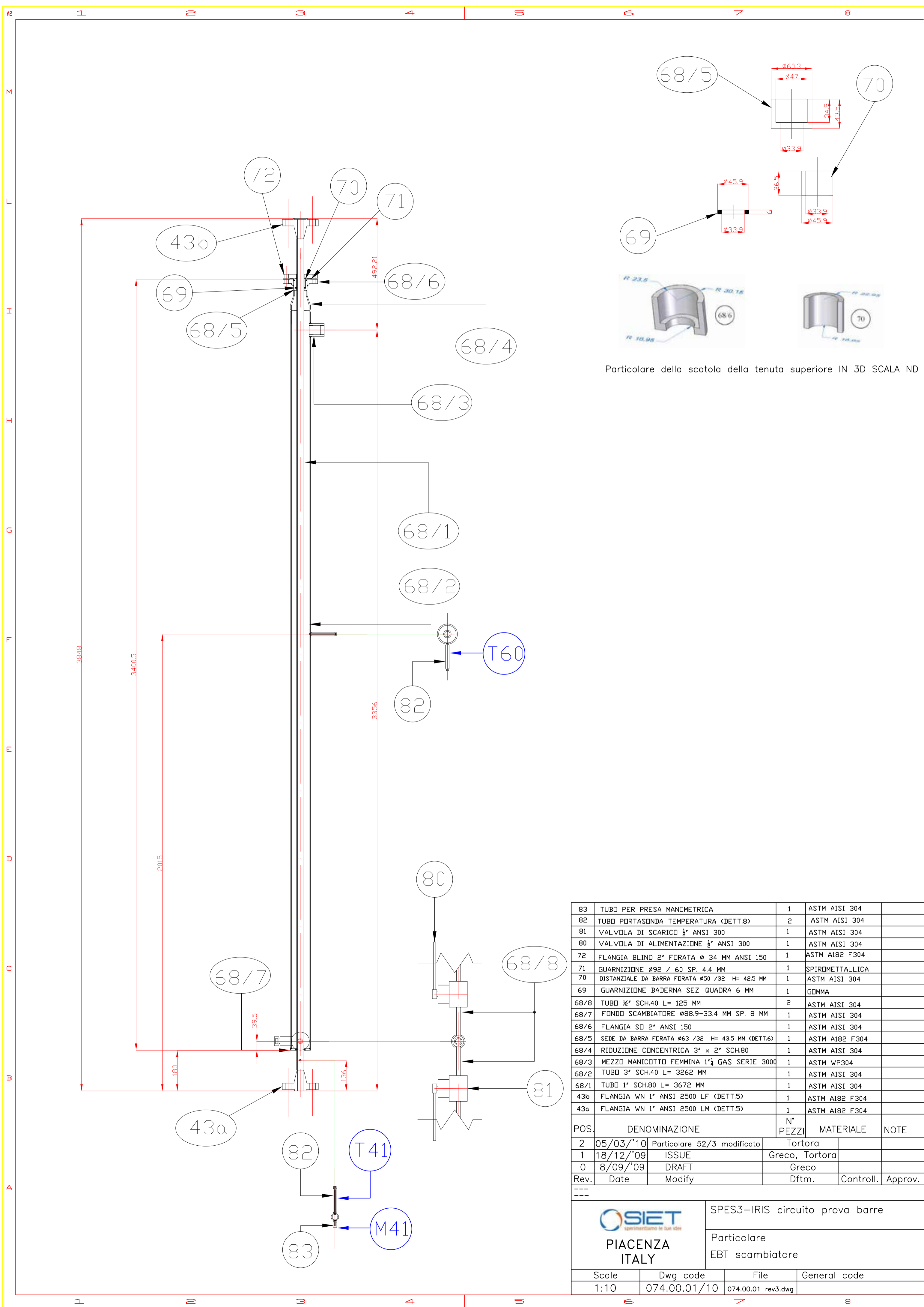

Particolare della scatola della tenuta superiore IN 3D SCALA ND

83	TUBO PER PRESA MANOMETRICA	1	ASTM AISI 304	
82	TUBO PORTASONDA TEMPERATURA (DETT.8)	2	ASTM AISI 304	
81	VALVOLA DI SCARICO 1/2" ANSI 300	1	ASTM AISI 304	
80	VALVOLA DI ALIMENTAZIONE 1/2" ANSI 300	1	ASTM AISI 304	
72	FLANGIA BLIND 2" FORATA Ø 34 MM ANSI 150	1	ASTM A182 F304	
71	GUARNIZIONE Ø92 / 60 SP. 4.4 MM	1	SPIROMETALLICA	
70	DISTANZIALE DA BARRA FORATA Ø50 /32 H= 42.5 MM	1	ASTM AISI 304	
69	GUARNIZIONE BADERNA SEZ. QUADRA 6 MM	1	GOMMA	
68/8	TUBO 1/2" SCH.40 L= 125 MM	2	ASTM AISI 304	
68/7	FONDO SCAMBIATORE Ø88.9-33.4 MM SP. 8 MM	1	ASTM AISI 304	
68/6	FLANGIA SD 2" ANSI 150	1	ASTM AISI 304	
68/5	SEDE DA BARRA FORATA Ø63 /32 H= 43.5 MM (DETT.6)	1	ASTM A182 F304	
68/4	RIDUZIONE CONCENTRICA 3" x 2" SCH.80	1	ASTM AISI 304	
68/3	MEZZO MANICOTTO FEMMINA 1 1/4" GAS SERIE 3000	1	ASTM WP304	
68/2	TUBO 3" SCH.40 L= 3262 MM	1	ASTM AISI 304	
68/1	TUBO 1" SCH.80 L= 3672 MM	1	ASTM AISI 304	
43b	FLANGIA WN 1" ANSI 2500 LF (DETT.5)	1	ASTM A182 F304	
43a	FLANGIA WN 1" ANSI 2500 LM (DETT.5)	1	ASTM A182 F304	

POS.	DENOMINAZIONE	N° PEZZI	MATERIALE	NOTE
2	05/03/'10 Particolare 52/3 modificato		Tortora	
1	18/12/'09 ISSUE		Greco, Tortora	
0	8/09/'09 DRAFT		Greco	
Rev.	Date	Modify	Dftm.	Controll. Approv.

<p>OSIET sperimentiamo le tue idee</p> <p>PIACENZA ITALY</p>	SPES3-IRIS circuito prova barre		
	Particolare EBT scambiatore		
Scale	Dwg code	File	General code
1:10	074.00.01/10	074.00.01 rev3.dwg	

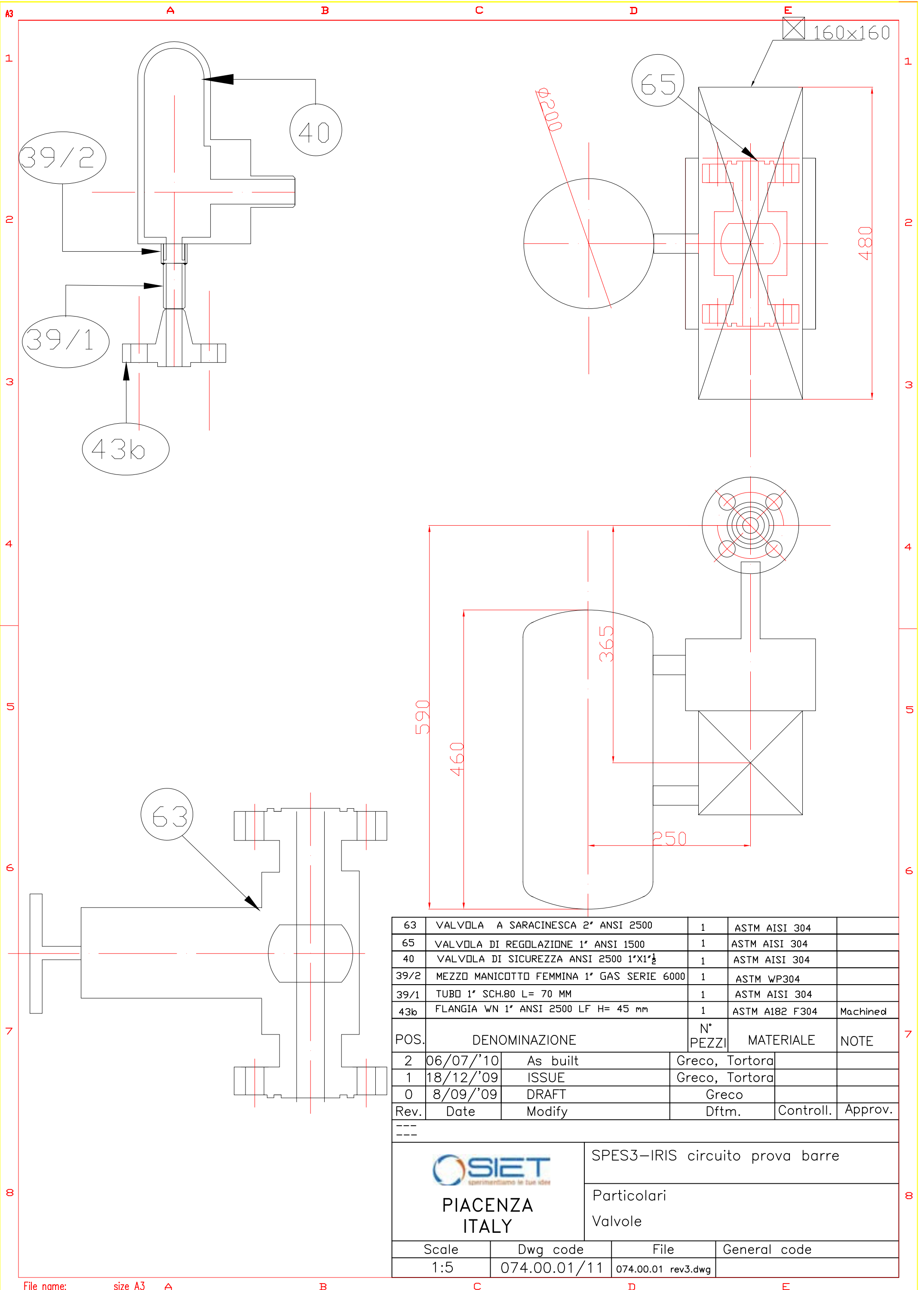

63	VALVOLA A SARACINESCA 2" ANSI 2500	1	ASTM AISI 304	
65	VALVOLA DI REGOLAZIONE 1" ANSI 1500	1	ASTM AISI 304	
40	VALVOLA DI SICUREZZA ANSI 2500 1"x1 1/2"	1	ASTM AISI 304	
39/2	MEZZO MANICOTTO FEMMINA 1" GAS SERIE 6000	1	ASTM WP304	
39/1	TUBO 1" SCH.80 L= 70 MM	1	ASTM AISI 304	
43b	FLANGIA WN 1" ANSI 2500 LF H= 45 mm	1	ASTM A182 F304	Machined
POS.	DENOMINAZIONE	N° PEZZI	MATERIALE	NOTE
2	06/07/'10 As built		Greco, Tortora	
1	18/12/'09 ISSUE		Greco, Tortora	
0	8/09/'09 DRAFT		Greco	
Rev.	Date	Modify	Dftm.	Controll. Approv.

 PIACENZA ITALY	SPES3-IRIS circuito prova barre		
	Particolari Valvole		
Scale	Dwg code	File	General code
1:5	074.00.01/11	074.00.01 rev3.dwg	

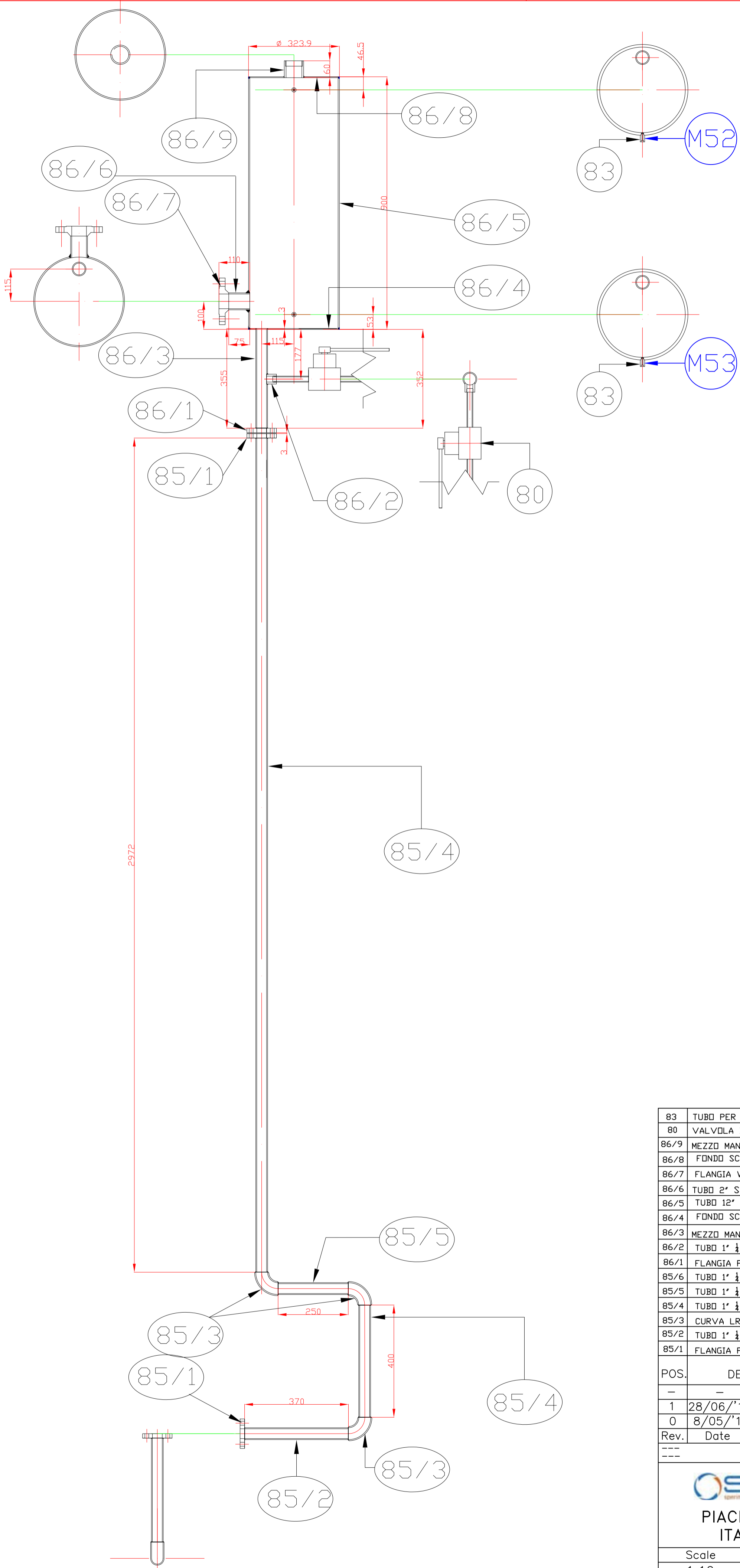

83	TUBO PER PRESA MANDMETRICA	2	ASTM AISI 304	
80	VALVOLA DI ALIMENTAZIONE 1/2" ANSI 300	1	ASTM AISI 304	
86/9	MEZZO MANICOTTO FEMMINA 2" GAS SERIE 3000	1	ASTM A234 WPB	
86/8	FONDO SCAMBIATORE Ø323.9-42.4 MM SP. 3 MM	1	ASTM AISI 304	
86/7	FLANGIA WN 2" ANSI 300	2	ASTM AISI 304	
86/6	TUBO 2" SCH. 40 L=75 MM	1	ASTM A234 WPB	
86/5	TUBO 12" SCH. 5S L=894 MM	1	ASTM AISI 304	
86/4	FONDO SCAMBIATORE Ø323.9-42.4 MM SP. 3 MM	1	ASTM AISI 304	
86/3	MEZZO MANICOTTO FEMMINA 3/4" GAS SERIE 3000	1	ASTM A234 WPB	
86/2	TUBO 1" 1/2 SCH. 40 L=250 MM	1	ASTM AISI 304	
86/1	FLANGIA PIANA 1 1/2" PN 16	1	ASTM A182 F304	
85/6	TUBO 1" 1/2 SCH. 40 L=2972 MM	1	ASTM AISI 304	
85/5	TUBO 1" 1/2 SCH. 40 L=250 MM	1	ASTM AISI 304	
85/4	TUBO 1" 1/2 SCH. 40 L=400 MM	1	ASTM AISI 304	
85/3	CURVA LR 1" 1/2 SCH 40	3	ASTM AISI 304	
85/2	TUBO 1" 1/2 SCH. 40 L=370 MM	1	ASTM A182 F304	
85/1	FLANGIA PIANA 1 1/2" PN 40	2	ASTM A182 F304	
POS.	DENOMINAZIONE	N° PEZZI	MATERIALE	NOTE
-	-	-	-	-
1	28/06/'10	ISSUE	Congiu, Tortora	
0	8/05/'10	DRAFT	Tortora	
Rev.	Date	Modify	Dftm.	Controll. Approv.

		SPES3-IRIS circuito prova barre		
PIACENZA ITALY		Particolare SISTEMI AUSILIARI: CIRCUITO REINTEGRO		
Scale	Dwg code	File	General code	
1:10	074.00.01/11-a	074.00.01rev3.dwg		

File name:

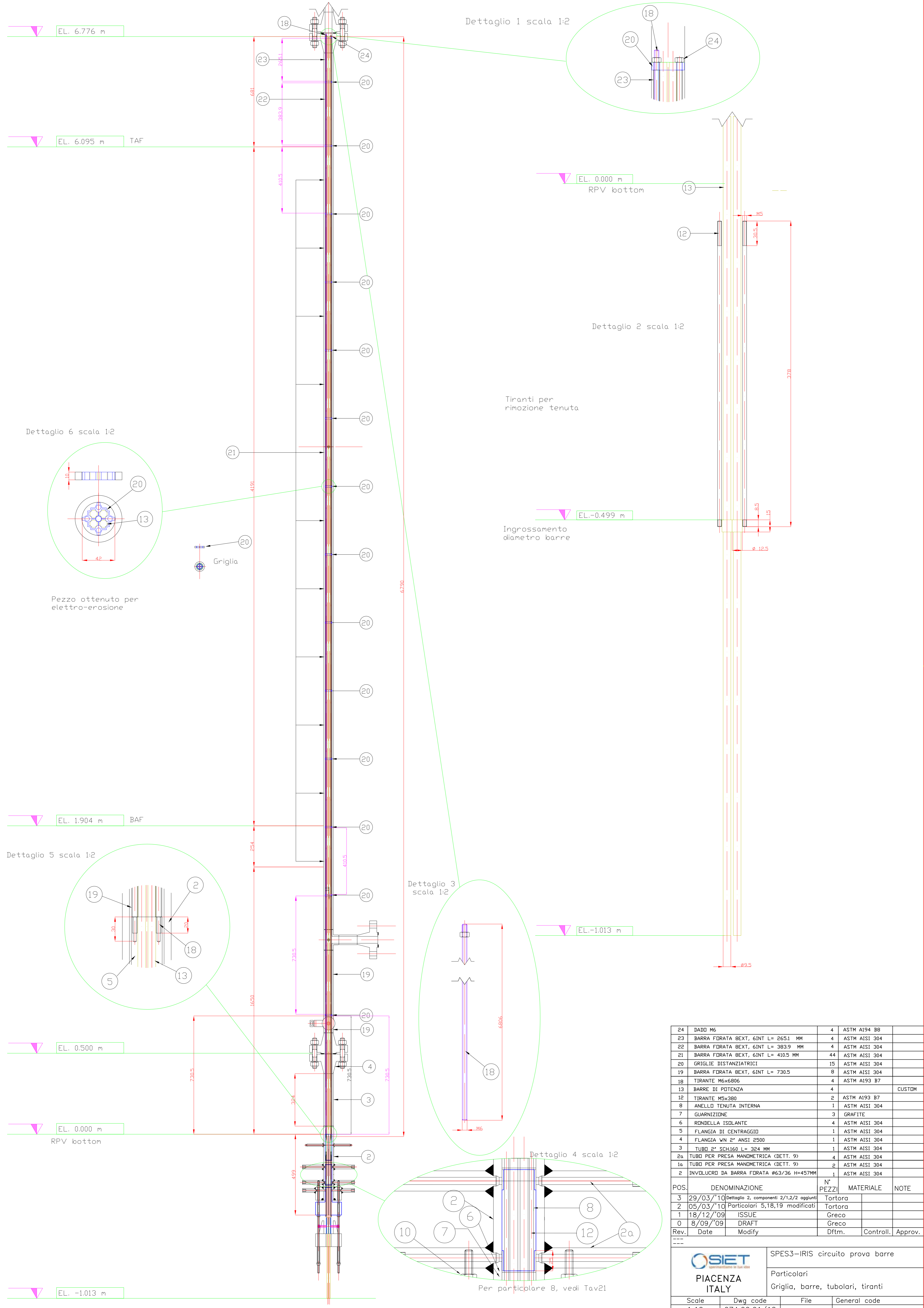

24	DADO M6	4	ASTM A194 B8	
23	BARRA FORATA BEXT, 6INT L= 265.1 MM	4	ASTM AISI 304	
22	BARRA FORATA BEXT, 6INT L= 383.9 MM	4	ASTM AISI 304	
21	BARRA FORATA BEXT, 6INT L= 410.5 MM	44	ASTM AISI 304	
20	GRIGLIE DISTANZIATRICI	15	ASTM AISI 304	
19	BARRA FORATA BEXT, 6INT L= 730.5	8	ASTM AISI 304	
18	TIRANTE M6x6806	4	ASTM A193 B7	
13	BARRE DI POTENZA	4		CUSTOM
12	TIRANTE M5x380	2	ASTM A193 B7	
8	ANELLO TENUTA INTERNA	1	ASTM AISI 304	
7	GUARNIZIONE	3	GRAFITE	
6	RONDELLA ISOLANTE	4	ASTM AISI 304	
5	FLANGIA DI CENTRAGGIO	1	ASTM AISI 304	
4	FLANGIA WN 2" ANSI 2500	1	ASTM AISI 304	
3	TUBO 2" SCH160 L= 324 MM	1	ASTM AISI 304	
2a	TUBO PER PRESA MANDMETRICA (DETT. 9)	4	ASTM AISI 304	
1a	TUBO PER PRESA MANDMETRICA (DETT. 9)	2	ASTM AISI 304	
2	INVOLUCRO DA BARRA FORATA Ø63/36 H=457MM	1	ASTM AISI 304	
POS.	DENOMINAZIONE	N° PEZZI	MATERIALE	NOTE
3	29/03/'10 Dettaglio 2, componenti 2/1,2/2 aggiunti		Tortora	
2	05/03/'10 Particolari 5,18,19 modificati		Tortora	
1	18/12/'09 ISSUE		Greco	
0	8/09/'09 DRAFT		Greco	
Rev.	Date	Modify	Dftm.	Controll. Approv.

		SPES3-IRIS circuito prova barre		
PIACENZA ITALY		Particolari Griglia, barre, tubolari, tiranti		
Scale	Dwg code	File	General code	
1:10	074.00.01/12	074.00.01 rev3.dwg		

File name:

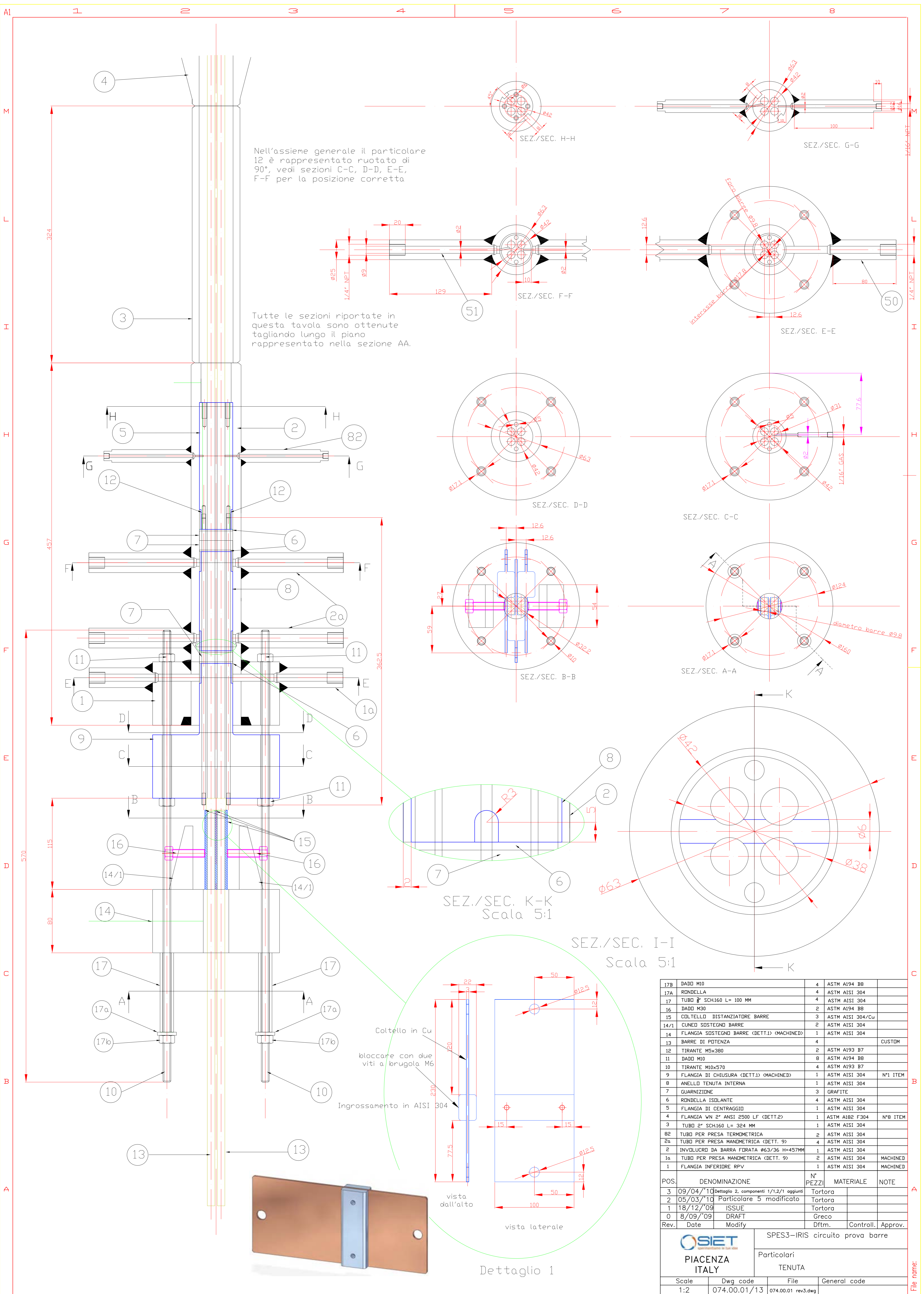

17B	DADO M10	4	ASTM A194 B8	
17A	RONDELLA	4	ASTM A194 B8	
17	TUBO 2" SCH160 L= 100 MM	4	ASTM A194 B8	
16	DADO M30	2	ASTM A194 B8	
15	COLTELLO DISTANZIATORE BARRE	3	ASTM A194 B8	
14/1	CUNED SOSTEGNO BARRE	2	ASTM A194 B8	
14	FLANGIA SOSTEGNO BARRE (DETT.1) (MACHINED)	1	ASTM A194 B8	
13	BARRE DI POTENZA	4	ASTM A194 B8	CUSTOM
12	TIRANTE M5x380	2	ASTM A193 B7	
11	DADO M10	8	ASTM A194 B8	
10	TIRANTE M10x570	4	ASTM A193 B7	
9	FLANGIA DI CHIUSURA (DETT.1) (MACHINED)	1	ASTM A194 B8	N°1 ITEM
8	ANELLO TENUTA INTERNA	1	ASTM A194 B8	
7	GUARNIZIONE	3	GRAFITE	
6	RONDELLA ISOLANTE	4	ASTM A194 B8	
5	FLANGIA DI CENTRAGGIO	1	ASTM A194 B8	
4	FLANGIA WN 2" ANSI 2500 LF (DETT.2)	1	ASTM A182 F304	N°8 ITEM
3	TUBO 2" SCH160 L= 324 MM	1	ASTM A194 B8	
82	TUBO PER PRESA TERMOMETRICA	2	ASTM A194 B8	
20	TUBO PER PRESA MANDMETRICA (DETT. 9)	4	ASTM A194 B8	
2	INVOLUCRO DA BARRA FORATA Ø63/36 H=457MM	1	ASTM A194 B8	
1a	TUBO PER PRESA MANDMETRICA (DETT. 9)	2	ASTM A194 B8	MACHINED
1	FLANGIA INFERIORE RPV	1	ASTM A194 B8	MACHINED
POS.	DENOMINAZIONE	N° PEZZI	MATERIALE	NOTE
3	09/04/10 Dettaglio 2, componenti 1/12/1 aggiunti		Tortora	
2	05/03/10 Particolare 5 modificato		Tortora	
1	18/12/09 ISSUE		Tortora	
0	8/09/09 DRAFT		Greco	
Rev.	Date	Modif	Dftm.	Controll. Approv.
		SPES3-IRIS circuito prova barre		
PIACENZA ITALY		Particolari TENUTA		
Scale	Dwg code	File	General code	
1:2	074.00.01/13	074.00.01 rev3.dwg		

File name:

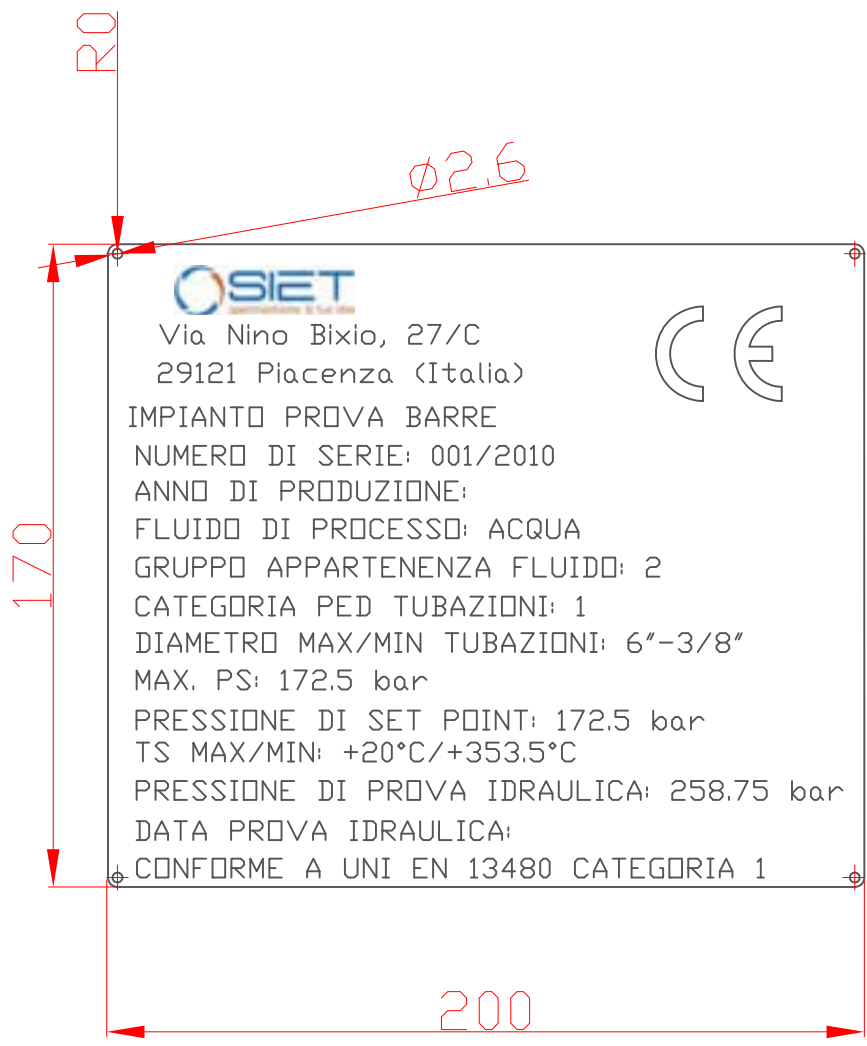

84	TARGHETTA DI IDENTIFICAZIONE IMPIANTO		1	Alluminio	
POS.	DENOMINAZIONE		N° PEZZI	MATERIALE	NOTE
2	08/07/'10	Aggiornata	Congiu		
1	18/12/'09	ISSUE	Greco, Tortora		
0	8/09/'09	DRAFT	Greco		
Rev.	Date	Modify	Dftm.	Controll.	Approv.
 PIACENZA ITALY			SPES3-IRIS circuito prova barre Particolari Targhetta		
Scale		Dwg code	File	General code	
1:2		074.00.01/14	074.00.01 rev3.dwg		

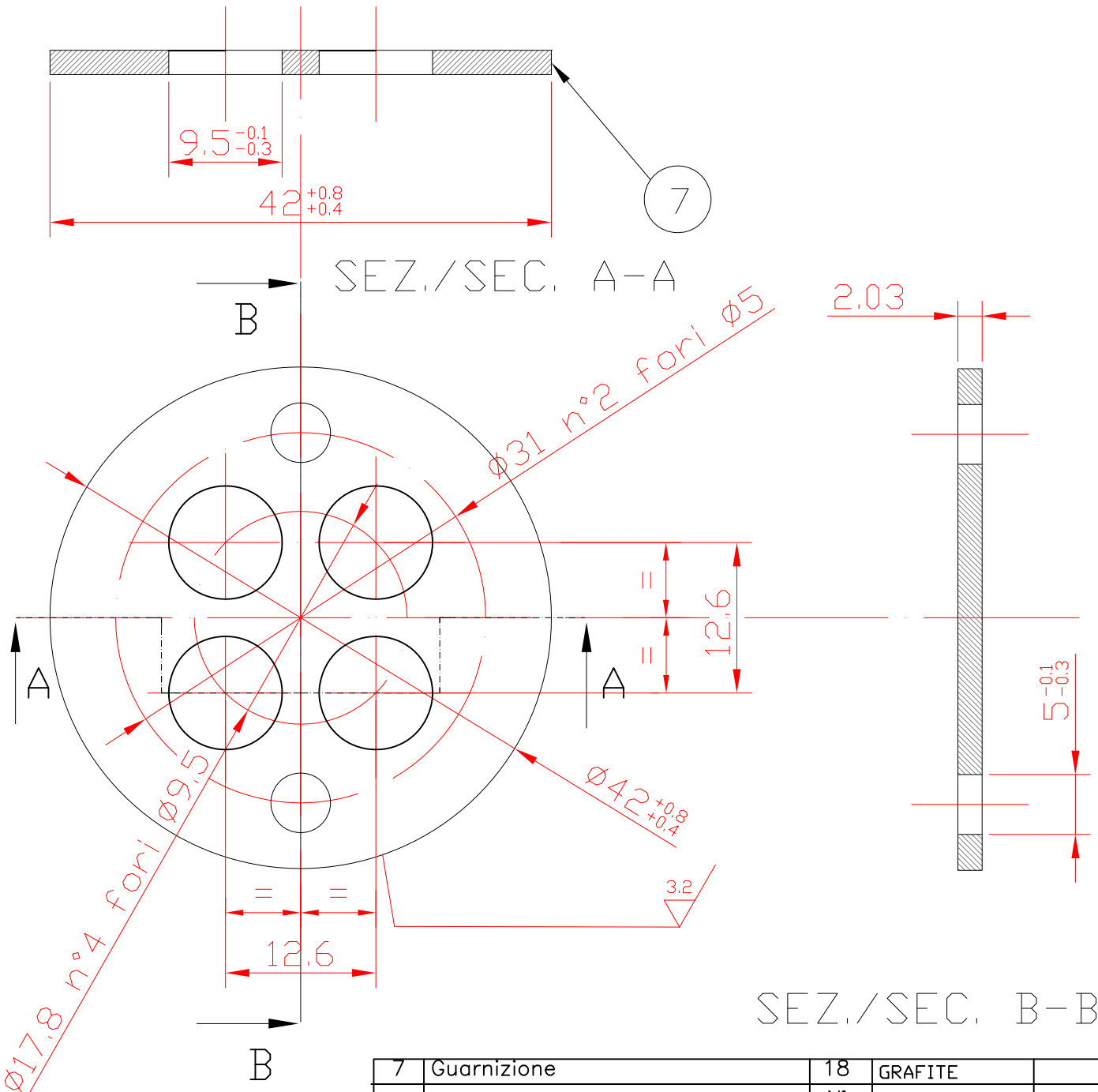

7	Guarnizione	18	GRAFITE	
POS.	DENOMINAZIONE	N° PEZZI	MATERIALE	NOTE
2	30/06/'10 DRAFT	Greco		
1	09/04/'10 DRAFT	Tortora		
0	18/12/'09 ISSUE	Greco,Tortora		
Rev.	Date	Modify	Dftm.	Controll. Approv.

Tolleranze generali -0.2/+0.2



SPES3-IRIS circuito prova barre
TENUTA
Particolari
Rondella isolante

Scale	Dwg code	File	General code
2:1	074.00.01/15	074.00.01 rev3.dwg	

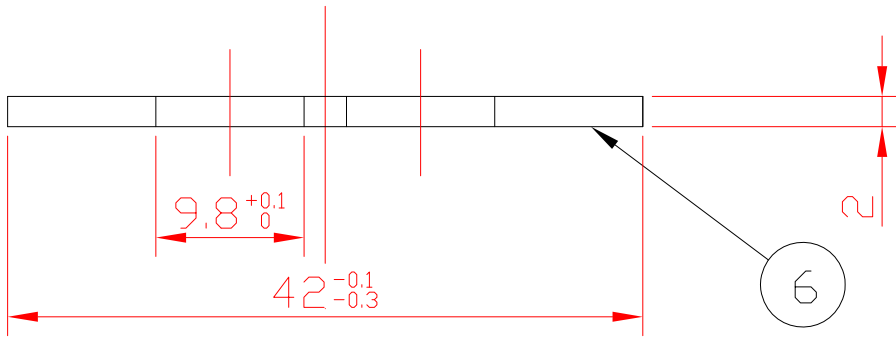

SEZ./SEC. A-A

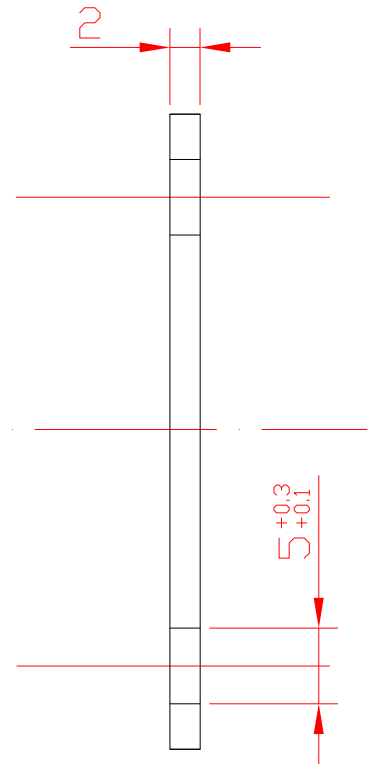
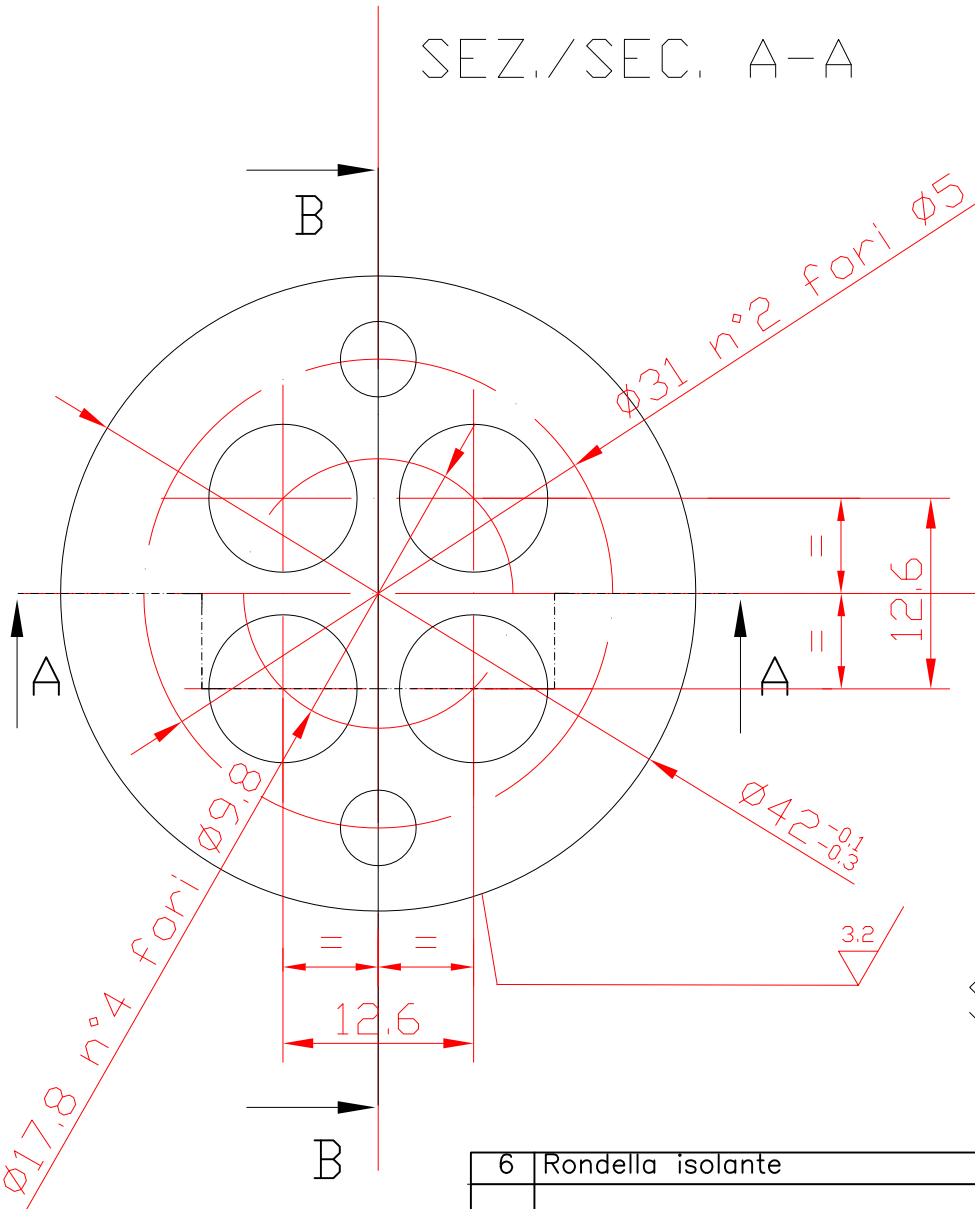

SEZ./SEC. B-B

6	Rondella isolante	20	ASTM AISI 304	
POS.	DENOMINAZIONE	N° PEZZI	MATERIALE	NOTE
1	09/04/'10 DRAFT		Tortora	
0	18/12/'09 ISSUE		Greco,Tortora	
Rev.	Date	Modify	Dftm.	Controll. Approv.

Tolleranze generali -0.2/+0.2



PIACENZA
ITALY

SPES3-IRIS circuito prova barre
TENUTA

Particolari
Rondella isolante

Scale	Dwg code	File	General code
2:1	074.00.01/16	074.00.01 rev3.dwg	

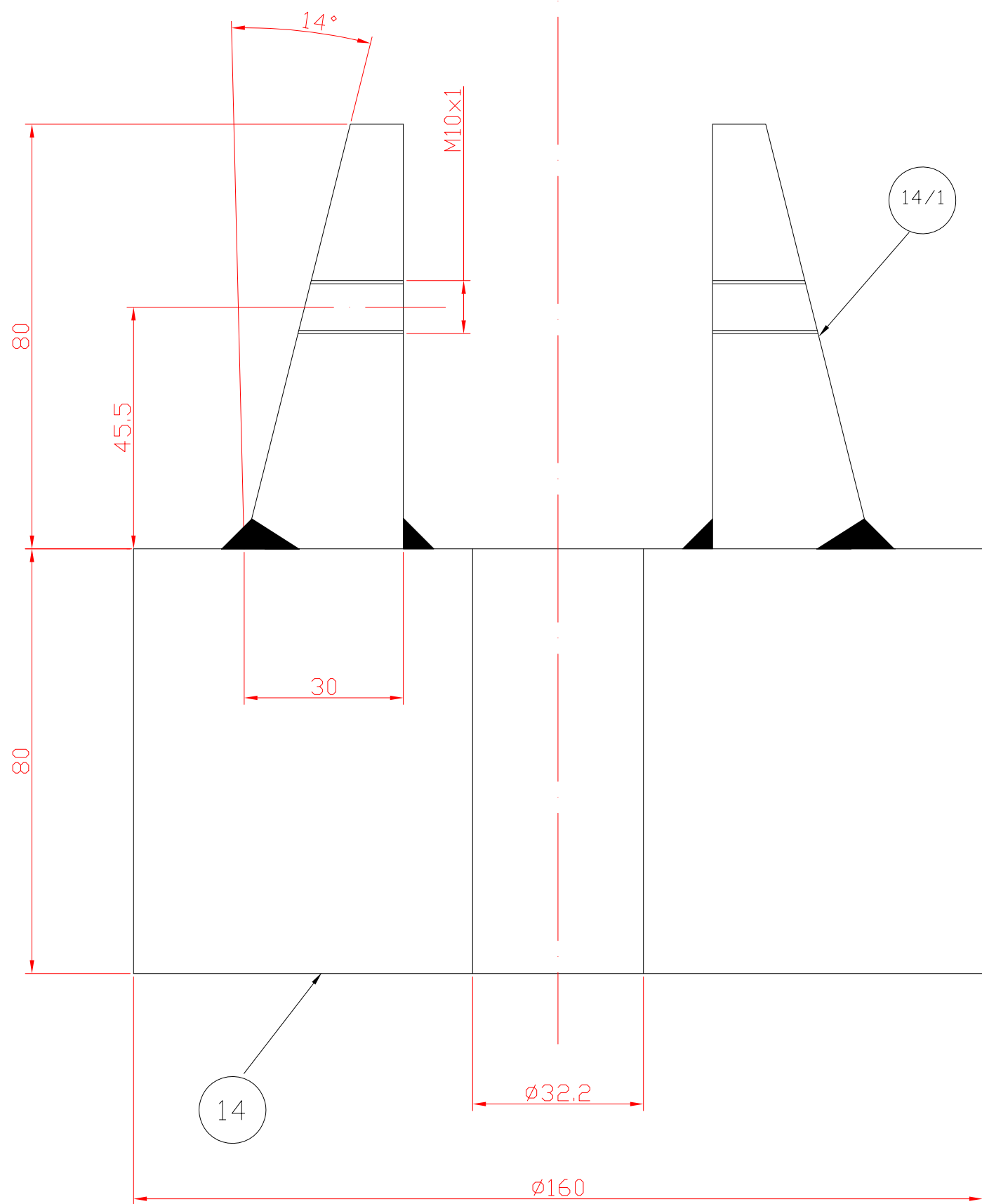

SEZ./SEC. A-A

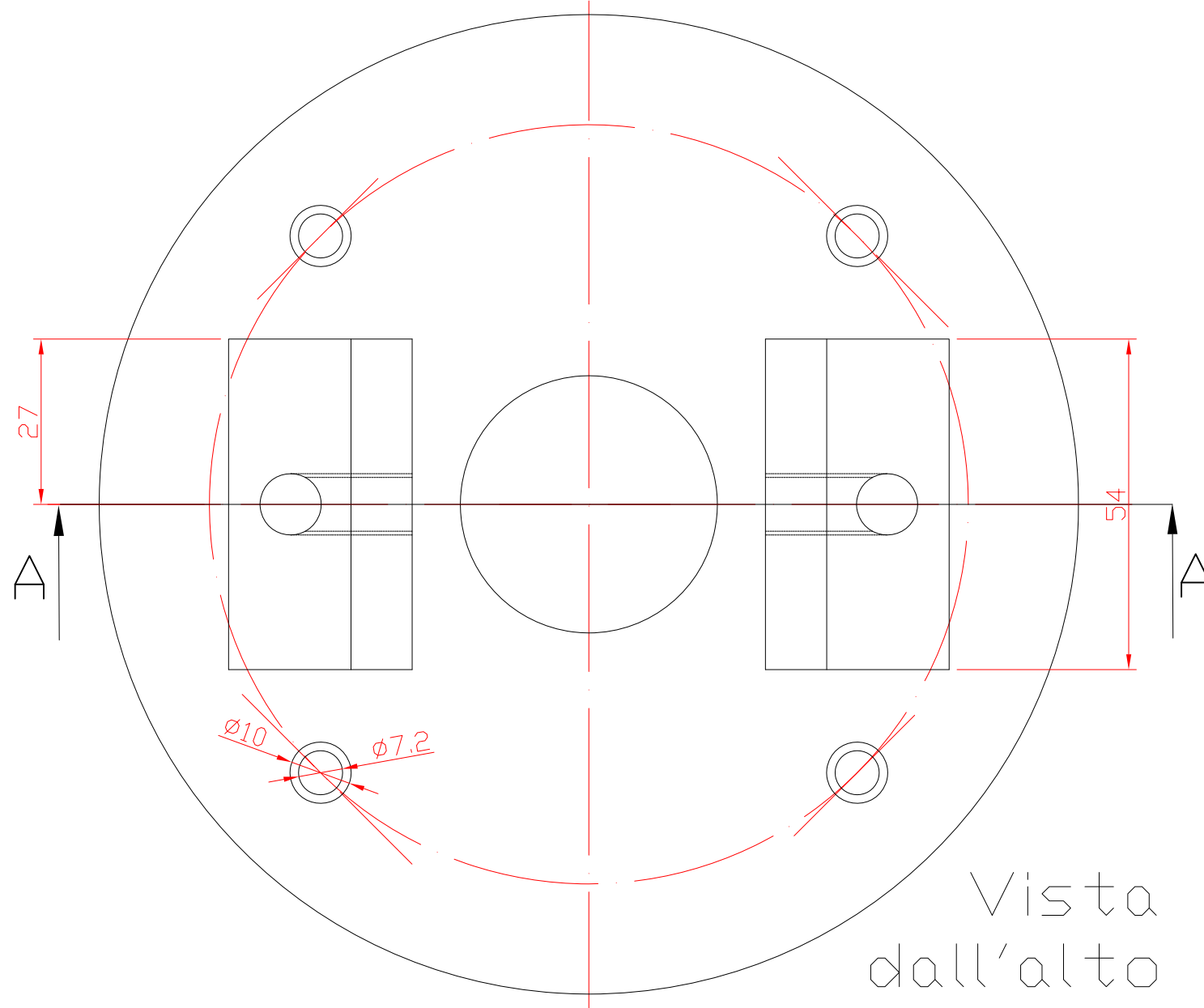

Vista dall'alto

14/1	Cuneo sostegno barre	2	ASTM AISI 304	
14	Flangia sostegno barre	1	ASTM AISI 304	
POS.	DENOMINAZIONE	N° PEZZI	MATERIALE	NOTE
1	09/04/'10 DRAFT		Greco,Tortora	
0	18/12/'09 ISSUE		Greco,Tortora	
Rev.	Date	Modify	Dftm.	Controll. Approv.

Tolleranze generali -0.2/+0.2



PIACENZA
ITALY

SPES3-IRIS circuito prova barre
TENUTA

Particolari
Flangia e cuneo sostegno barre

Scale	Dwg code	File	General code
1:1	074.00.01/17	074.00.01 rev3.dwg	

1 2 3 4 5 6 7 8

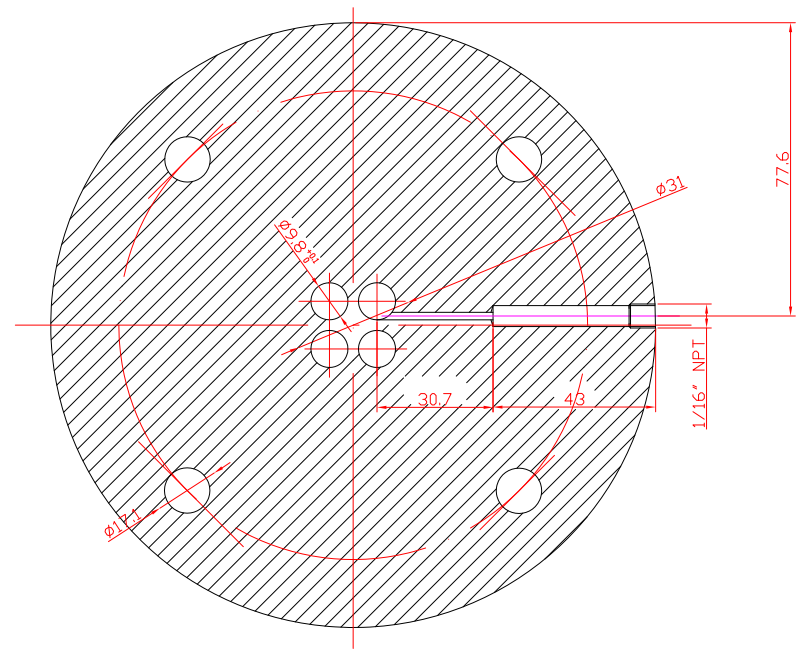
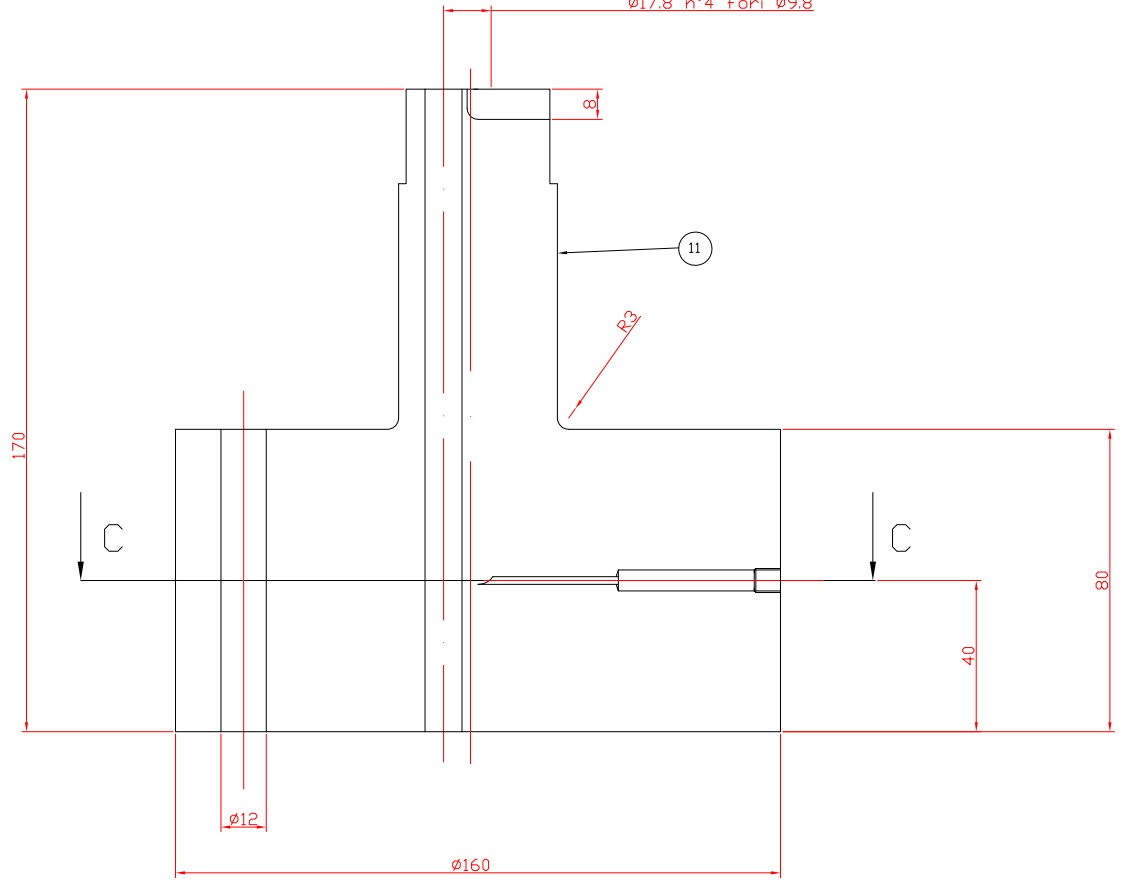
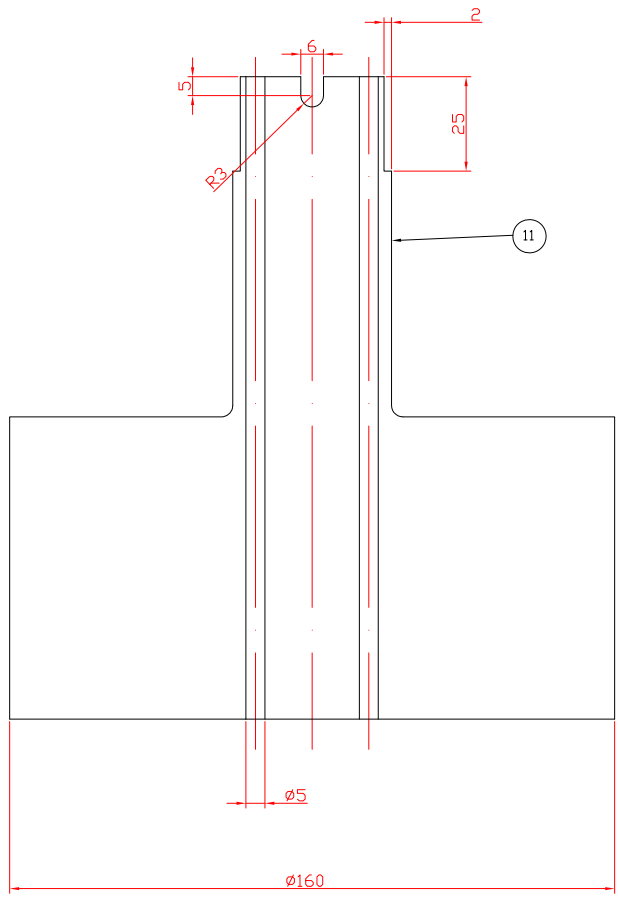
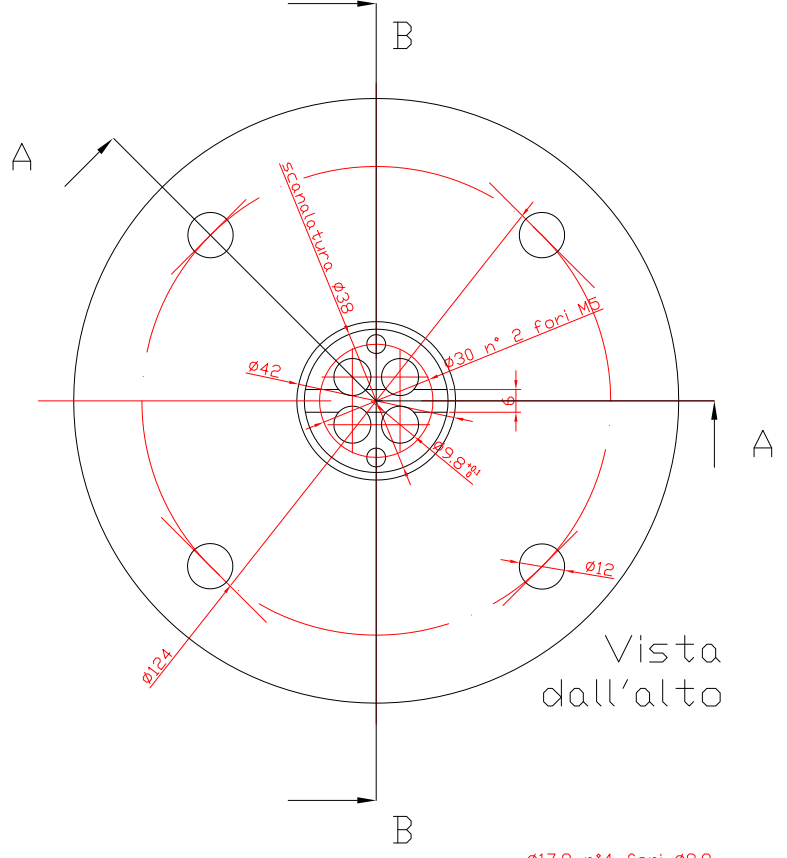

9	Flangia di chiusura	1	ASTM AISI 304	MACHINED
POS.	DENOMINAZIONE	N° PEZZI	MATERIALE	NOTE
1	09/04/'10 DRAFT		Tortora	
0	18/12/'09 ISSUE		Greco,Tortora	
Rev.	Date	Modify	Dftm.	Controll. Approv.

Tolleranze generali -0.2/+0.2			
 PIACENZA ITALY		SPES3-IRIS circuito prova barre TENUTA	
		Particolari Flangia di chiusura	
Scale	Dwg code	File	General code
1:2	074.00.01/18	074.00.01 rev3.dwg	

1 2 3 4 5 6 7 8

File name:

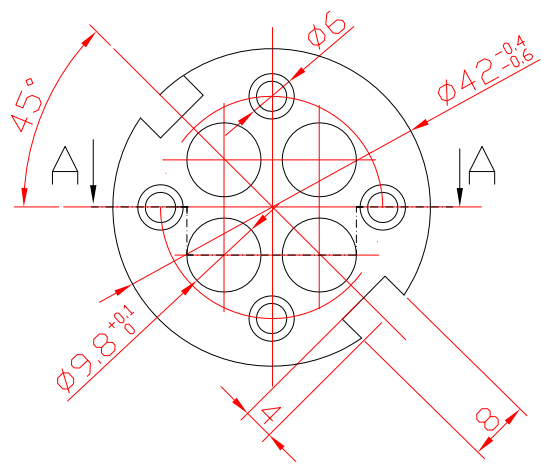

Vista dall'alto

Nella sezione A-A i fori da 5 mm sono ruotati di 90°, la loro posizione corretta è riportata nelle viste.

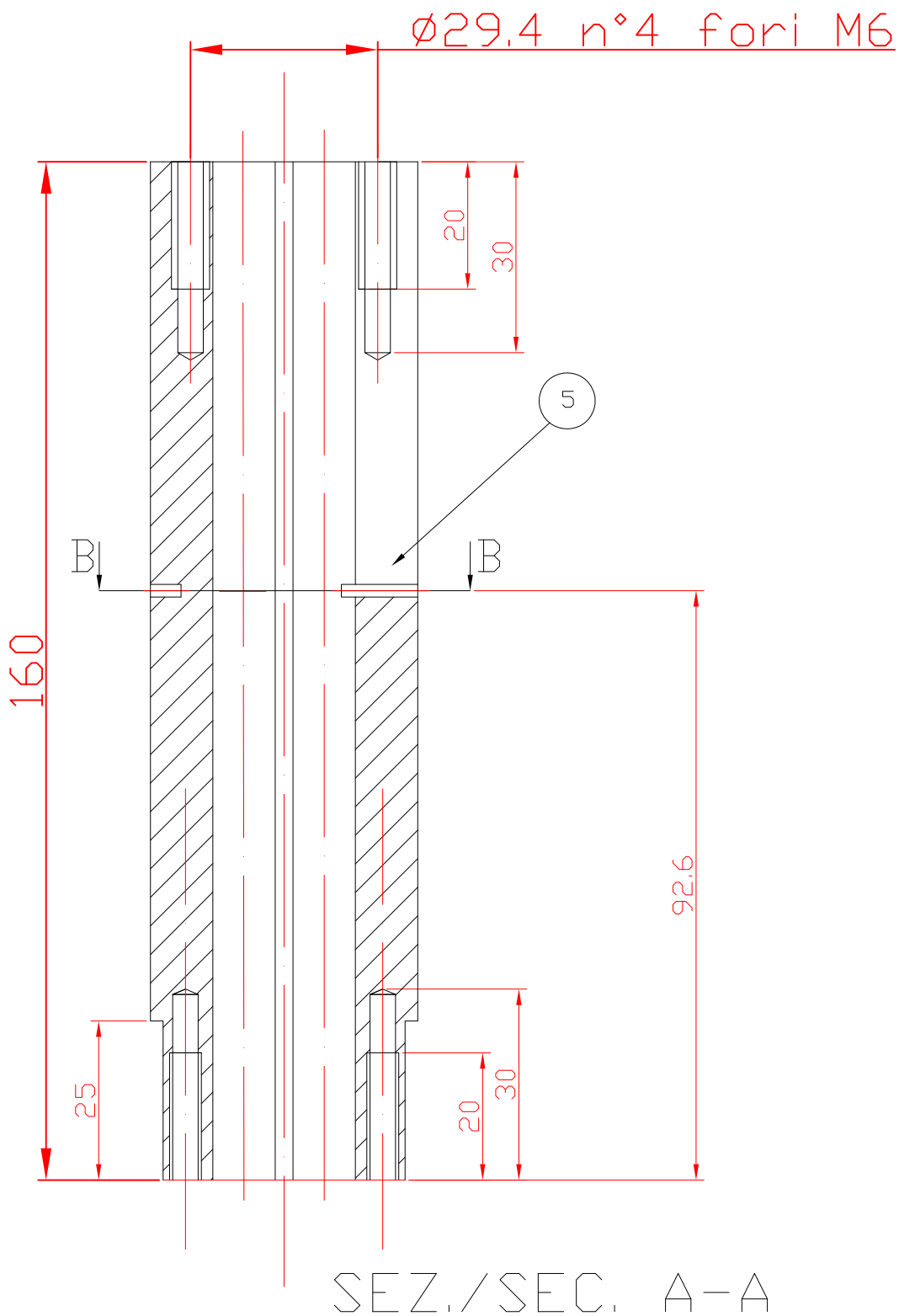

SEZ./SEC. A-A

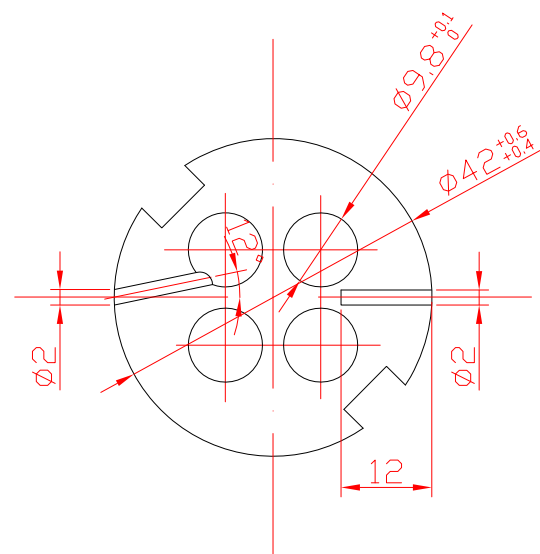

SEZ./SEC. B-B

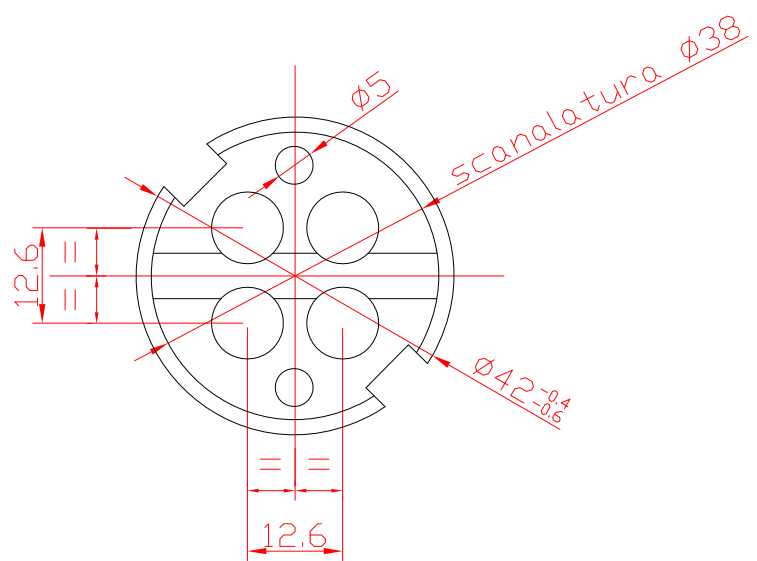

Vista dal basso

5	Flangia di centraggio	1	ASTM AISI 304	
POS.	DENOMINAZIONE	N° PEZZI	MATERIALE	NOTE
1	09/04/'10 DRAFT		Tortora	
0	18/12/'09 ISSUE		Greco,Tortora	
Rev.	Date	Modify	Dftm.	Controll. Approv.

Tolleranze generali $-0.2/+0.2$



PIACENZA
ITALY

SPES3-IRIS circuito prova barre
TENUTA

Particolari
Flangia di centraggio

Scale	Dwg code	File	General code
1:1	074.00.01/19	074.00.01 rev3.dwg	

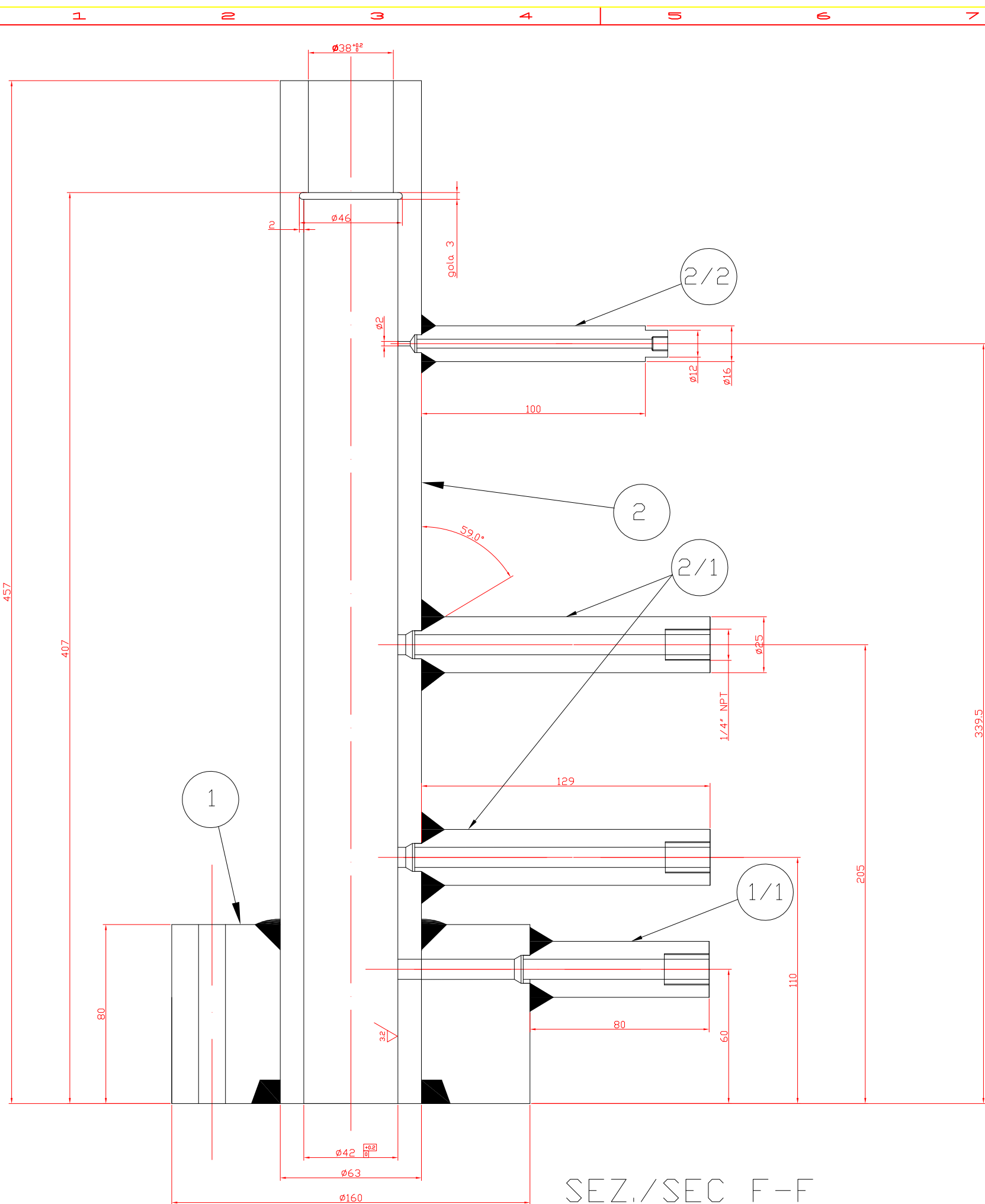

SEZ./SEC F-F

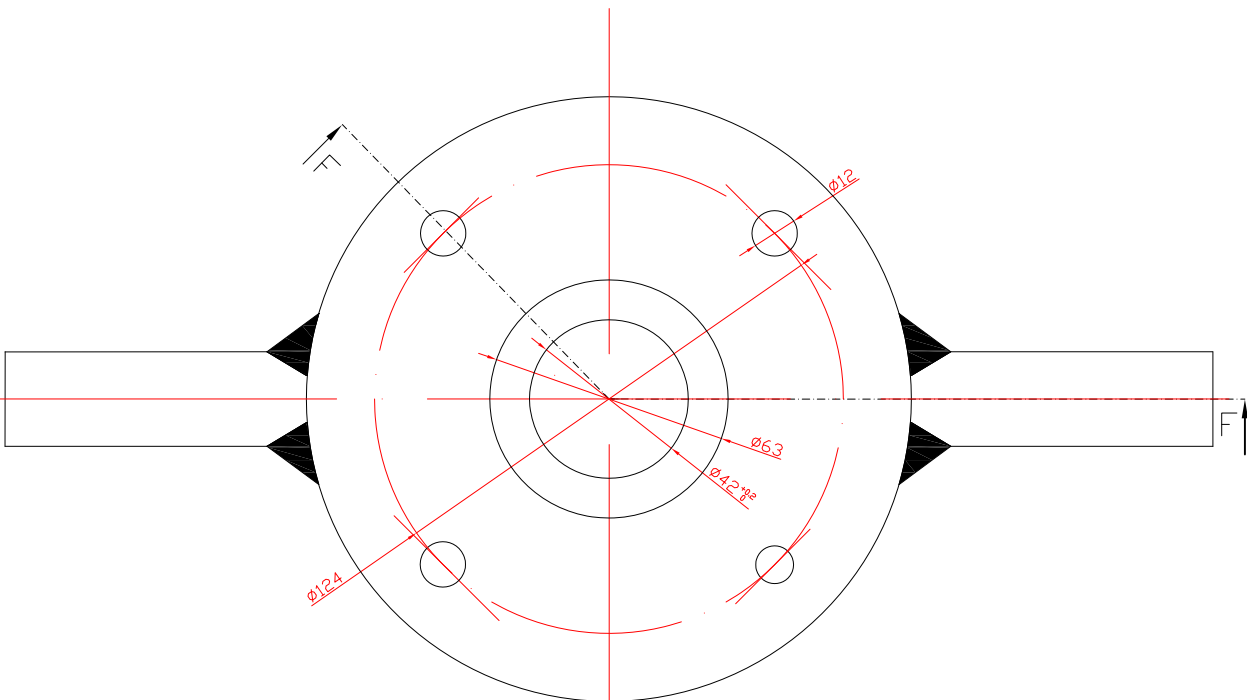

Vista dal basso

1	Flangia inferiore RPV	1	ASTM AISI 304	MACHINED
1/1	Tubo per presa manometrica	2	ASTM AISI 304	
2	Involucro da barra forata	1	ASTM AISI 304	
2/1	Tubo per presa manometrica	4	ASTM AISI 304	
2/2	tubo per presa termometrica	2	ASTM AISI 304	
POS.	DENOMINAZIONE	N° PEZZI	MATERIALE	NOTE
1	09/04/'10 DRAFT		Tortora	
0	18/12/'09 ISSUE		Greco,Tortora	
Rev.	Date	Modify	Dftm.	Controll. Approv.
Tolleranze generali -0.2/+0.2				
 PIACENZA ITALY		SPES3-IRIS circuito prova barre TENUTA		
		Particolari Flangia inferiore RPV e involucro		
Scale	Dwg code	File	General code	
1:2	074.00.01/20	074.00.01 rev3.dwg		

File name:

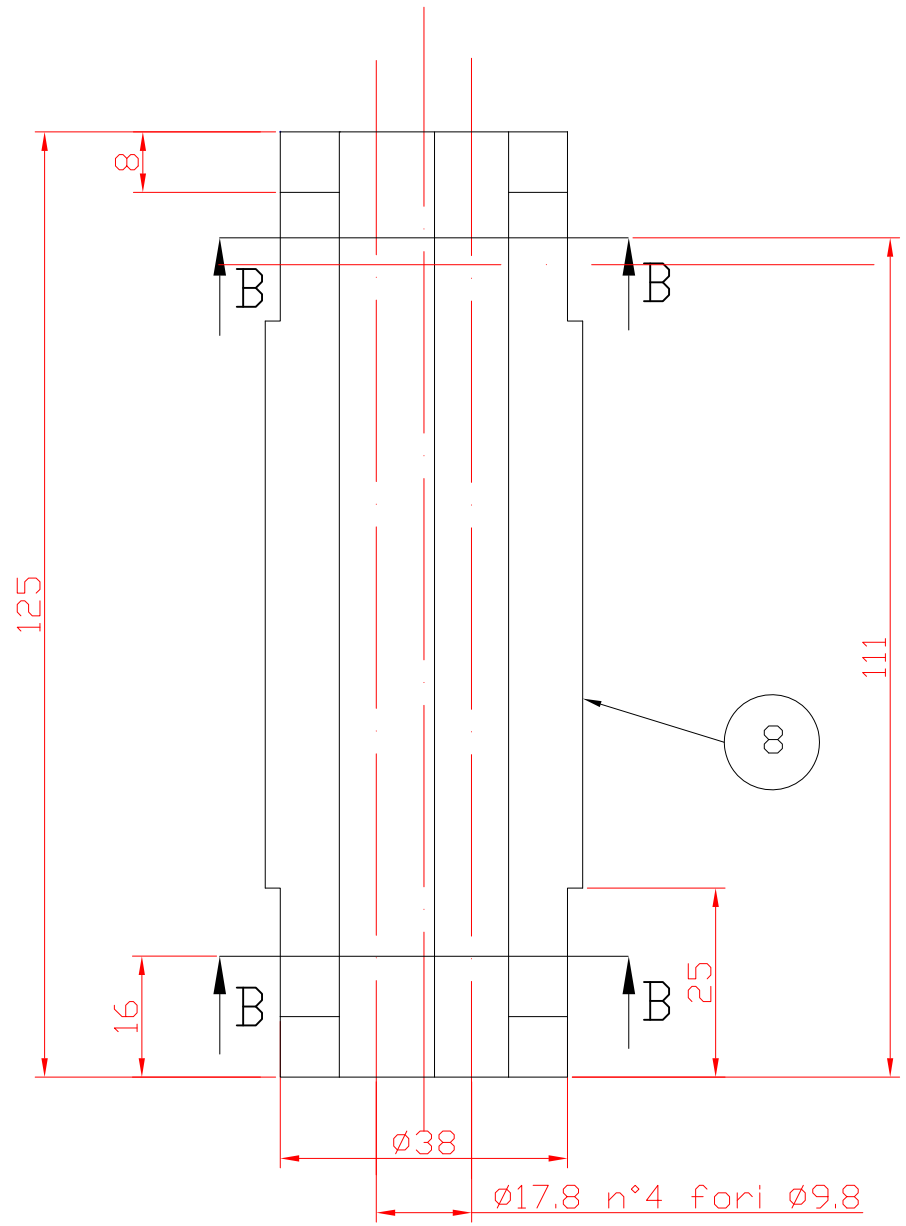
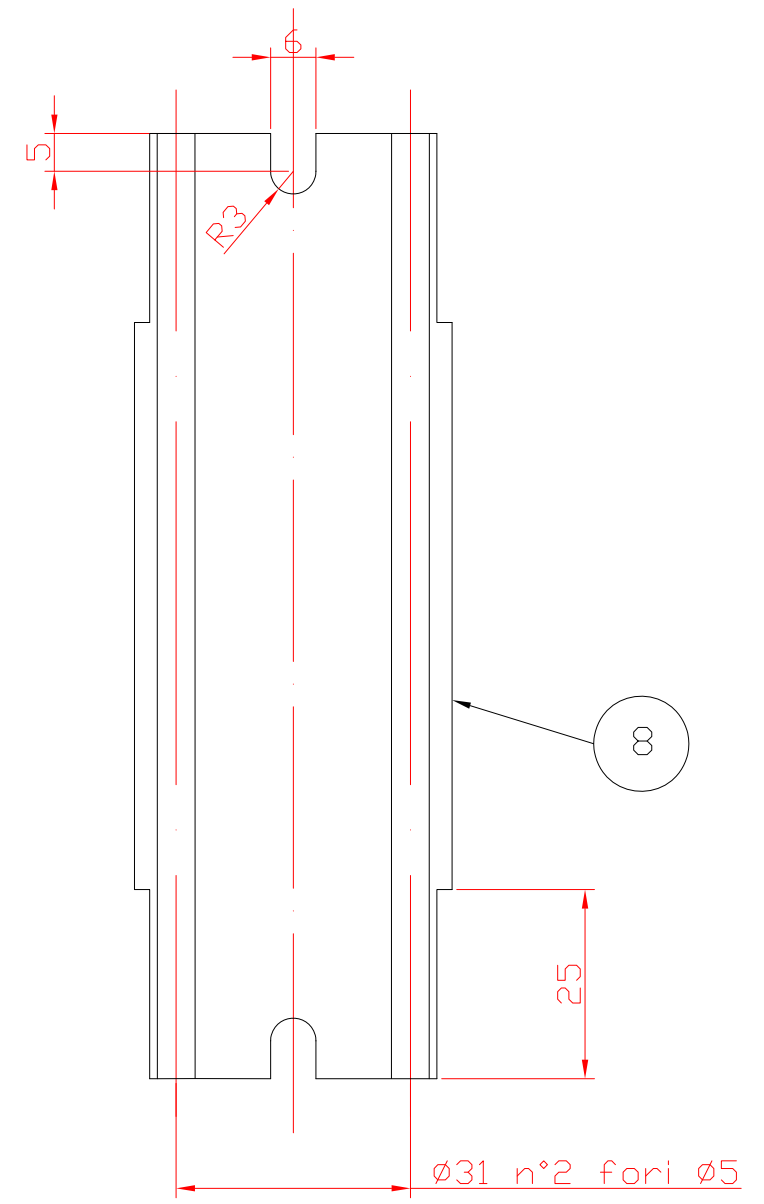
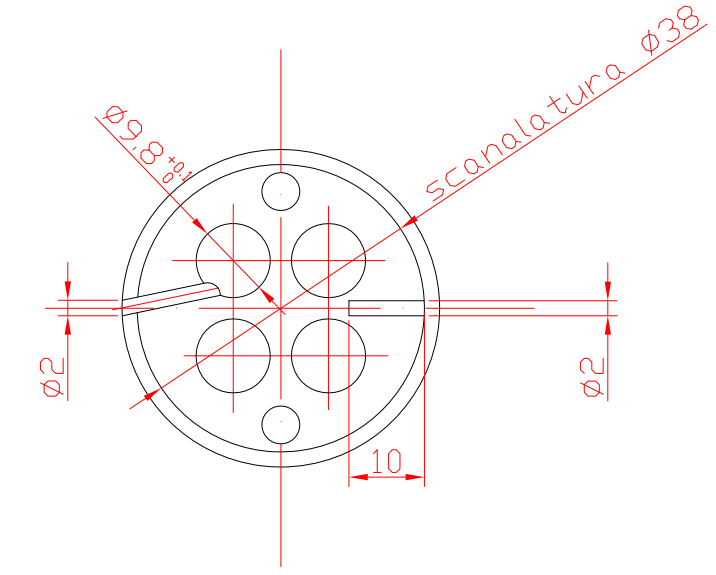
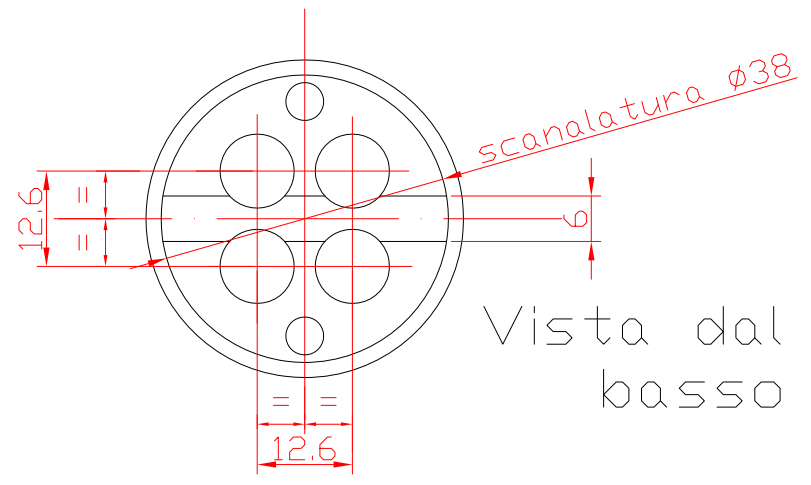
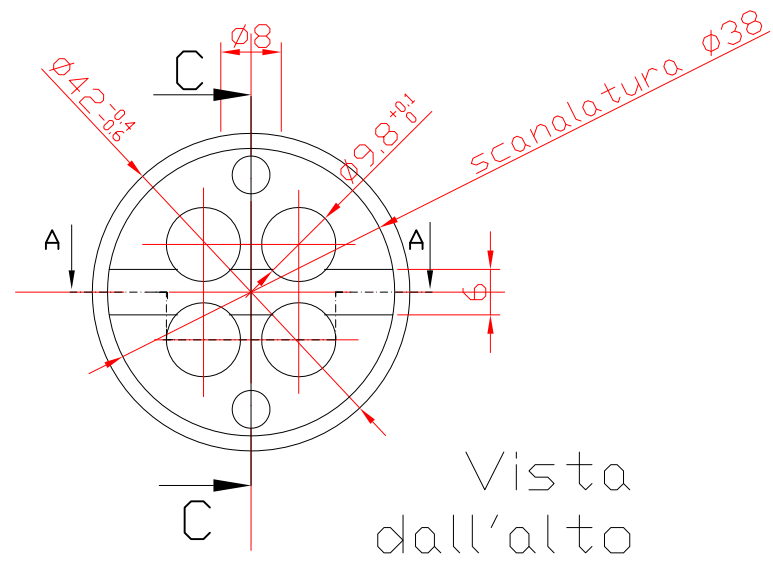

POS.	DENOMINAZIONE	N° PEZZI	MATERIALE	NOTE
8	Anello tenuta interna	1	ASTM AISI 304	
1	09/04/'10	DRAFT	Tortora	
0	18/12/'09	ISSUE	Greco, Tortora	
Rev.	Date	Modify	Dftm.	Controll. Approv.

Tolleranze generali -0.2/+0.2

<p>PIACENZA ITALY</p>	SPES3-IRIS circuito prova barre TENUTA		
	Particolari Anello tenuta interna		
Scale	Dwg code	File	General code
1:1	074.00.01/21	074.00.01 rev3.dwg	

File name: NONE

074-00-02rev2:

Assieme inserito nella struttura (4 fogli)

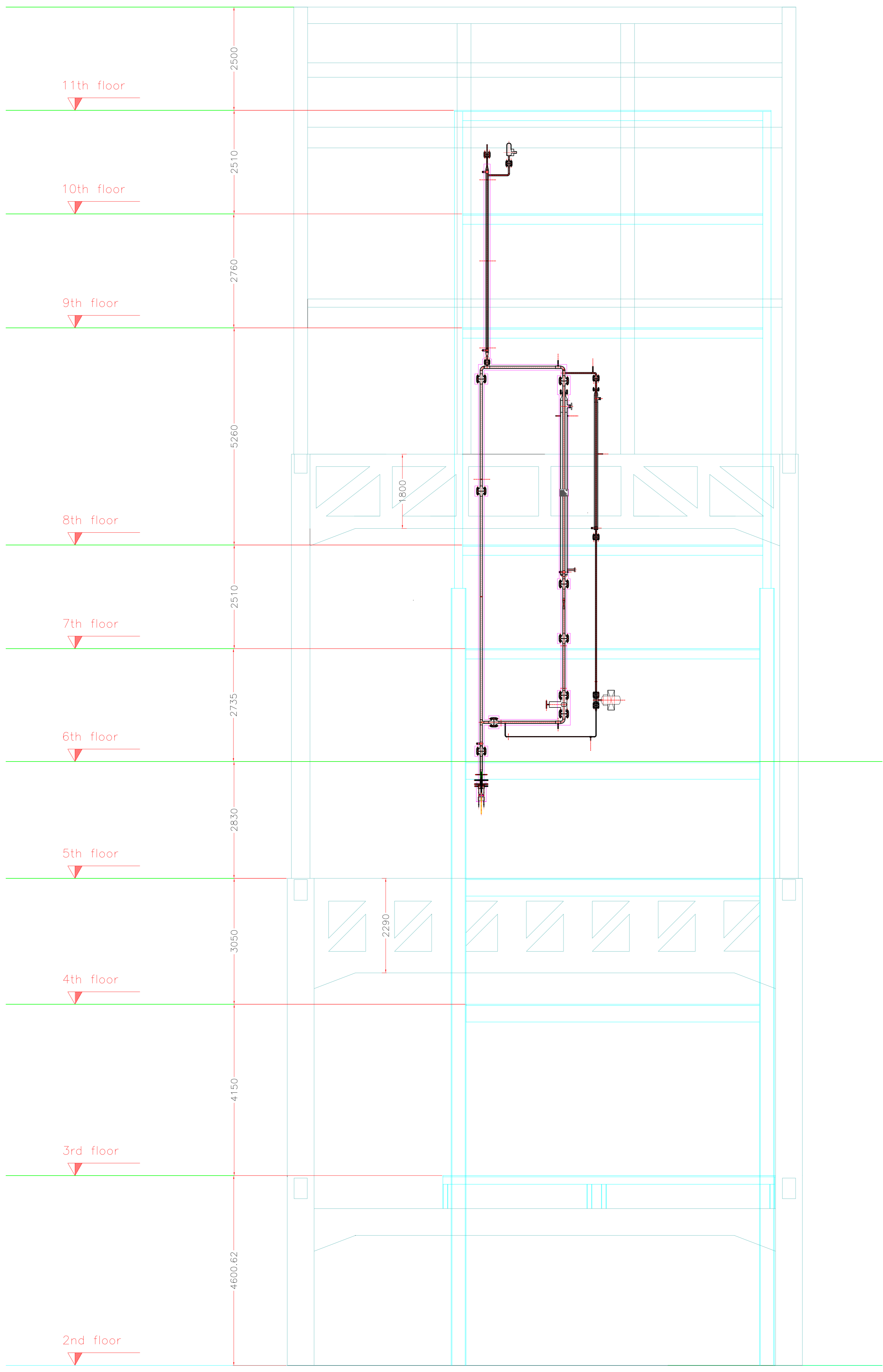

2	05/07/2010	As built	Congiu		
1	18/12/2009	ISSUE	Greco, Tortora		
0	01/09/2009	DRAFT	M. Greco	C. Congiu	A. Achilli
Rev.	Date	Modified	Dftm.	Controll.	Approv.
					
Piacenza - Italy			Impianto prova barre Posizionamento sulla struttura Vista frontale con coibentazione		
Scale	Dwg code	File	General code		
1:50	074.00.02/1	074.00.02rev2.dwg			

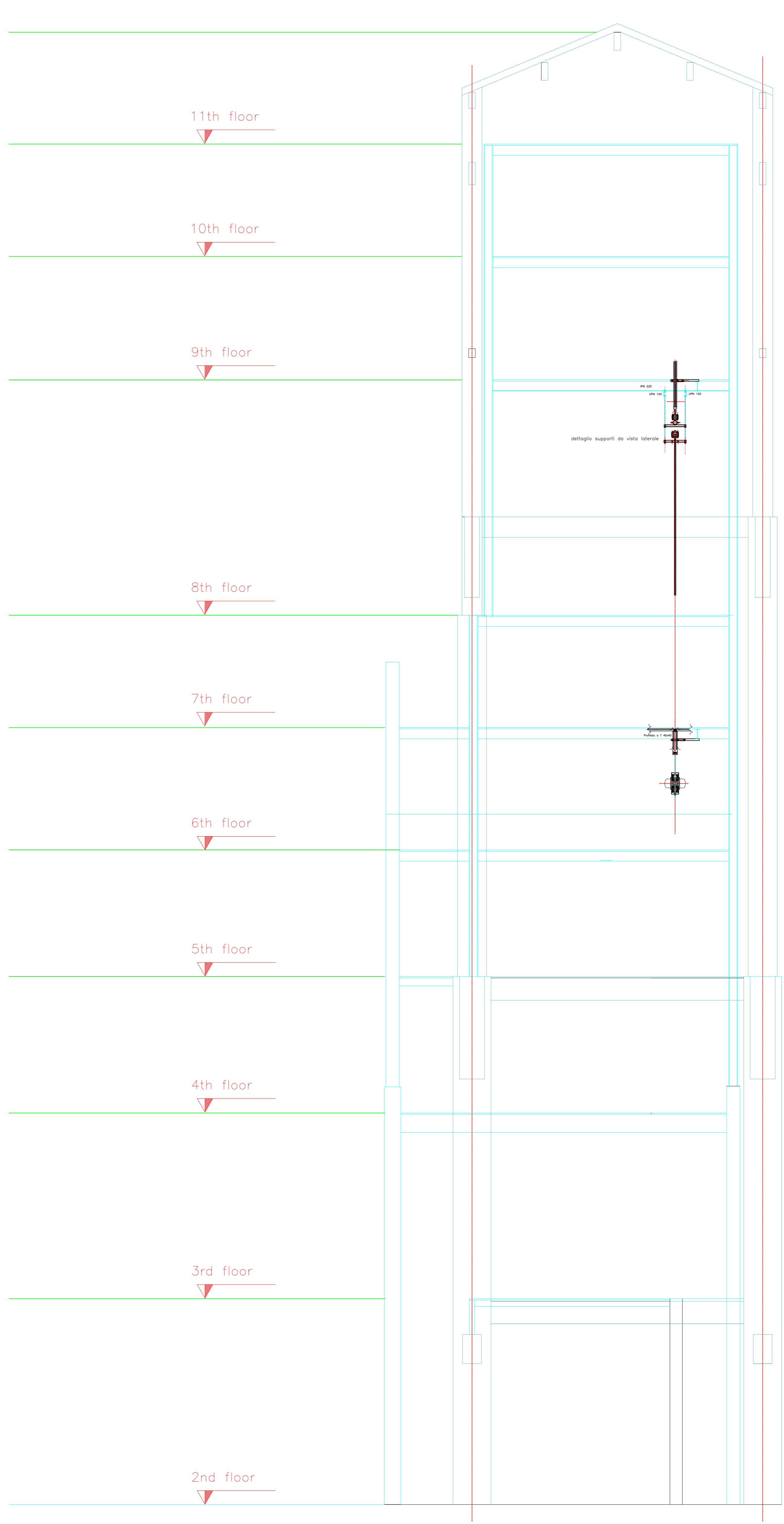

1	18/12/2009	ISSUE	Greco, Tortora		
0	01/09/2009	DRAFT	M. Greco	C. Congiu	A. Achilli
Rev.	Date	Modified	Dftm.	Control.	Approv.
					
Piacenza - Italy			Impianto prova barre Posizionamento sulla struttura Vista laterale		
Scale	Dwg code	File	General code		
1:50	074.00.02/2	074.00.02rev2.dwg			

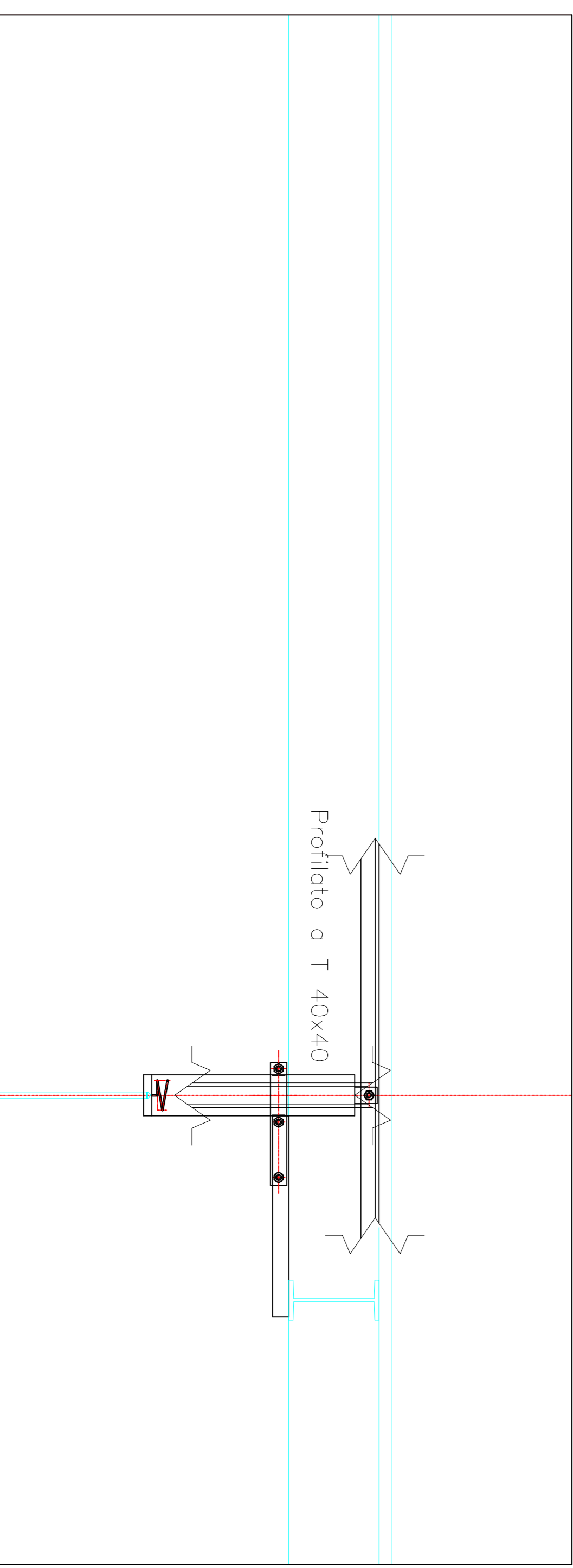
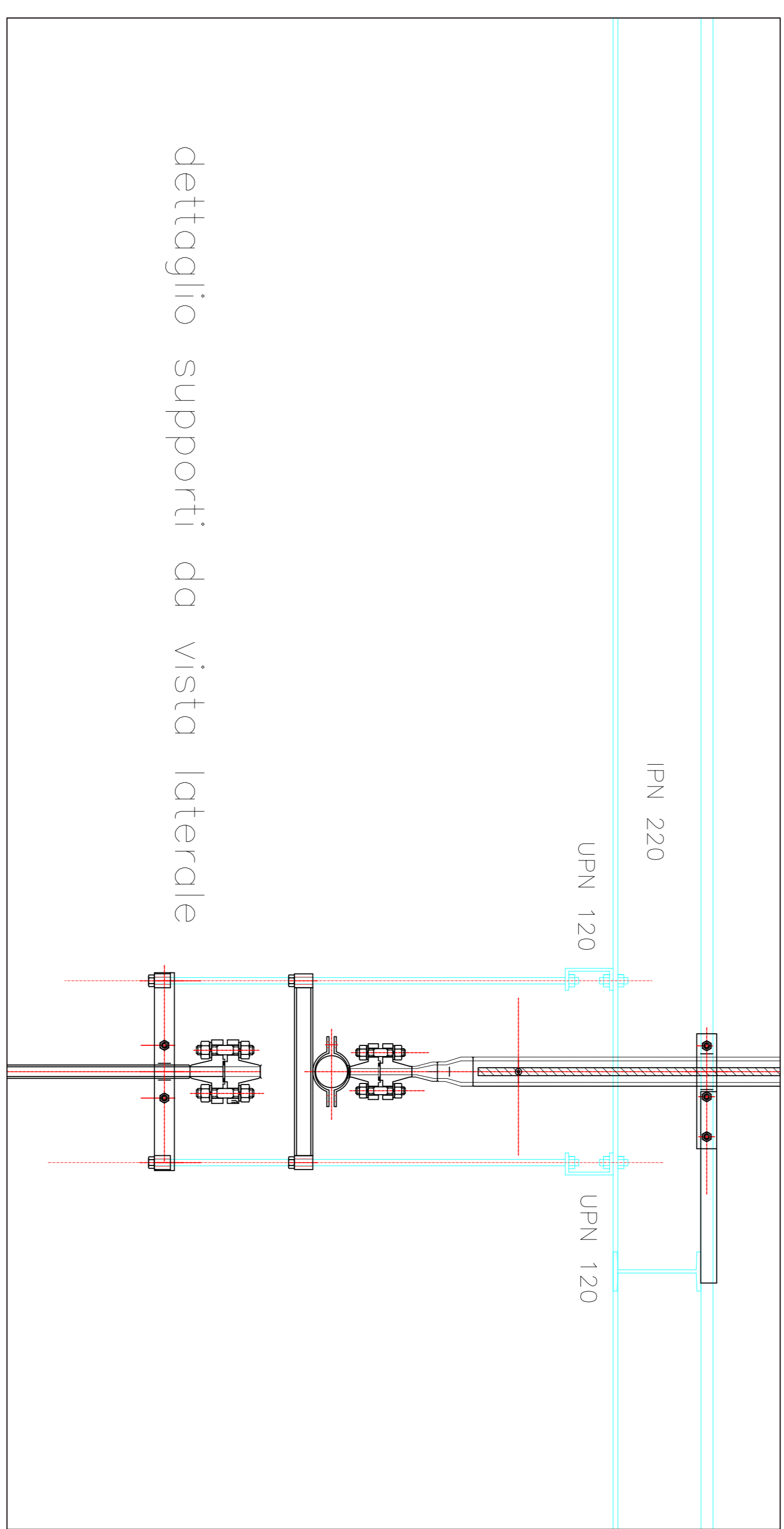
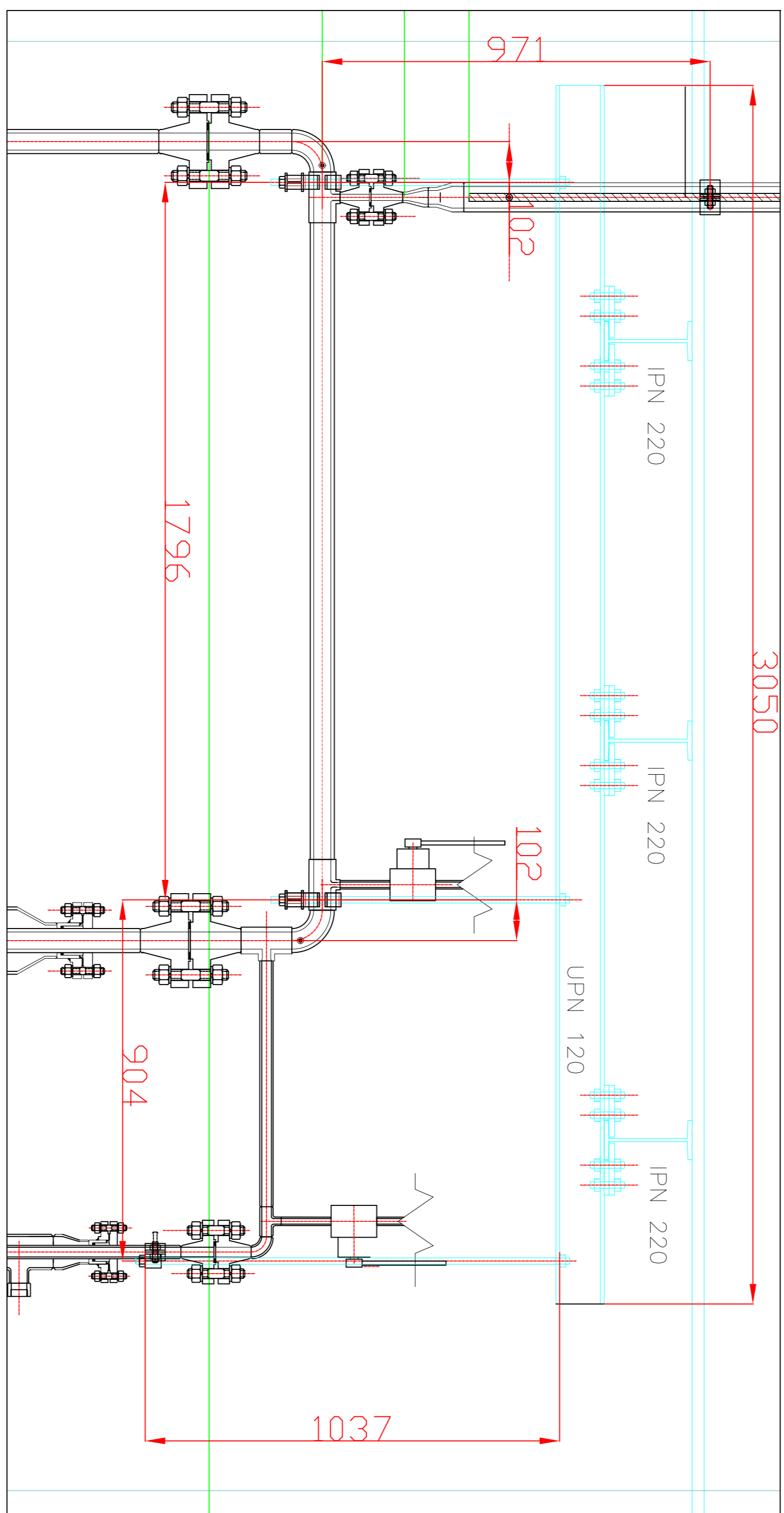
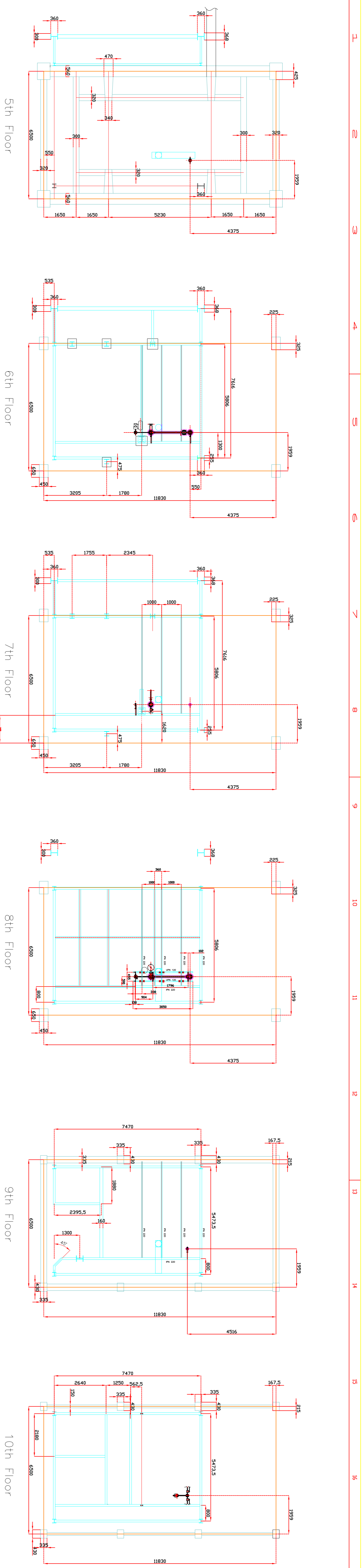

Vista laterale dei supporti scala 1:10

2	05/07/2010	As built	Congiu	
1	18/12/2009	ISSUE	Greco Torfard	
0	01/09/2009	DRAFT	M. Greco	C. Congiu A. Achilli
Rev.	Date	Modified	Ditm.	Controlli Approv.
Impianto prova barre				
Posizionamento sulla struttura				
Piazzenza - Italy				
Scale	Dwg code	File	General code	
1:100	074.00.02/3	074.00.02rev2.dwg		

taglio supporto per EBT

staffe disuguali sagomate in piatto 50*5, bloccate con 2 viti M14. serrate al tubo. Alla più lunga sono saldati, all'estremità, 2 tondi $\varnothing 35/18$, entro i quali passano i tiranti M16 che si collegano alla trave UPN 120. La distanza tra le piastre e la sagomatura sono adattate sul diametro esterno del tubo.

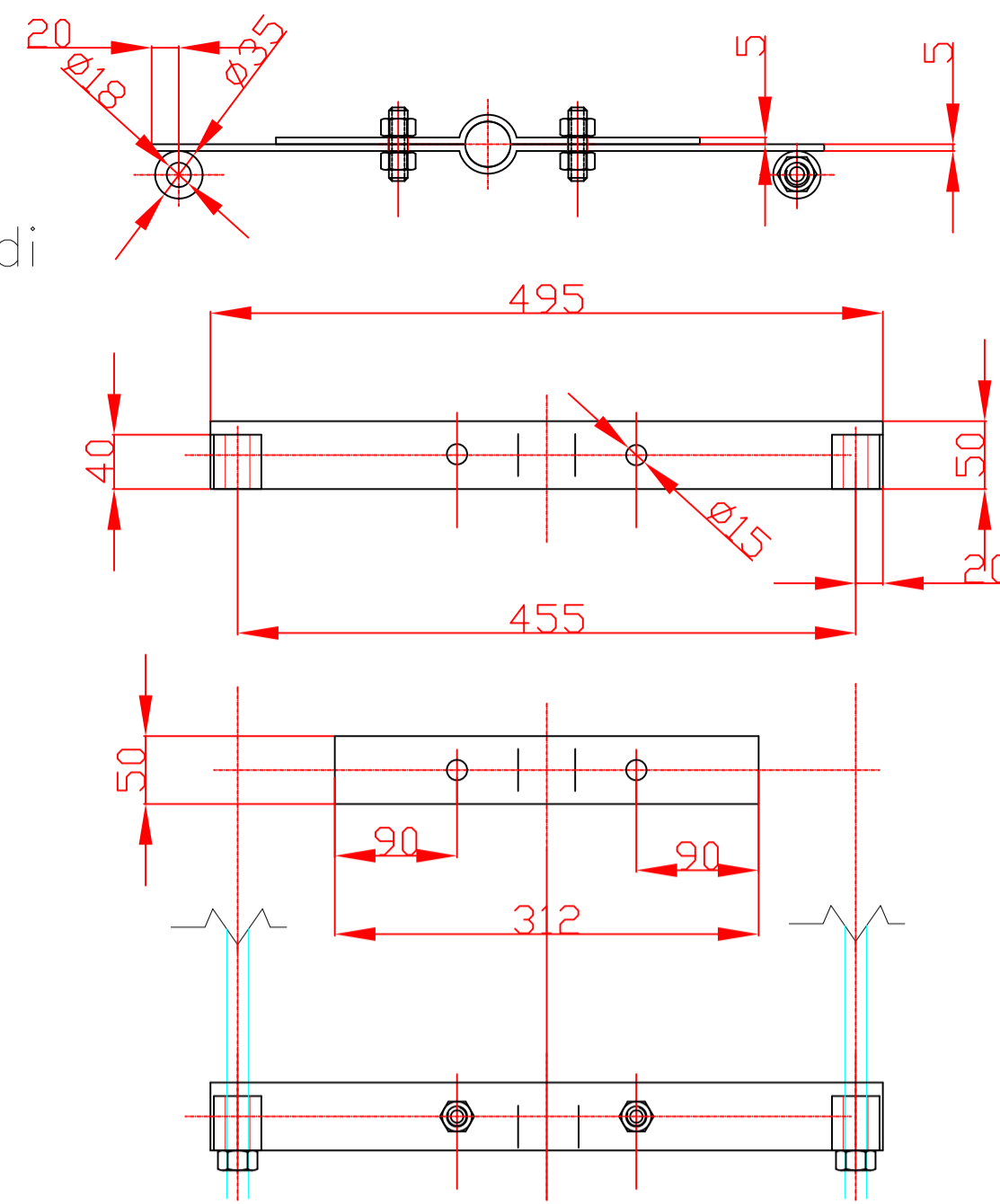

Dettaglio supporti intermedi su tubo da 2" e 1"

staffe sagomate in piatto 40*5, bloccate con 6 viti M14, tra le 4 della parte più lunga è serrata una trave a L 40x40, saldata a trave IPN 220. La distanza tra le piastre e la sagomatura sono adattate sul diametro esterno del tubo.

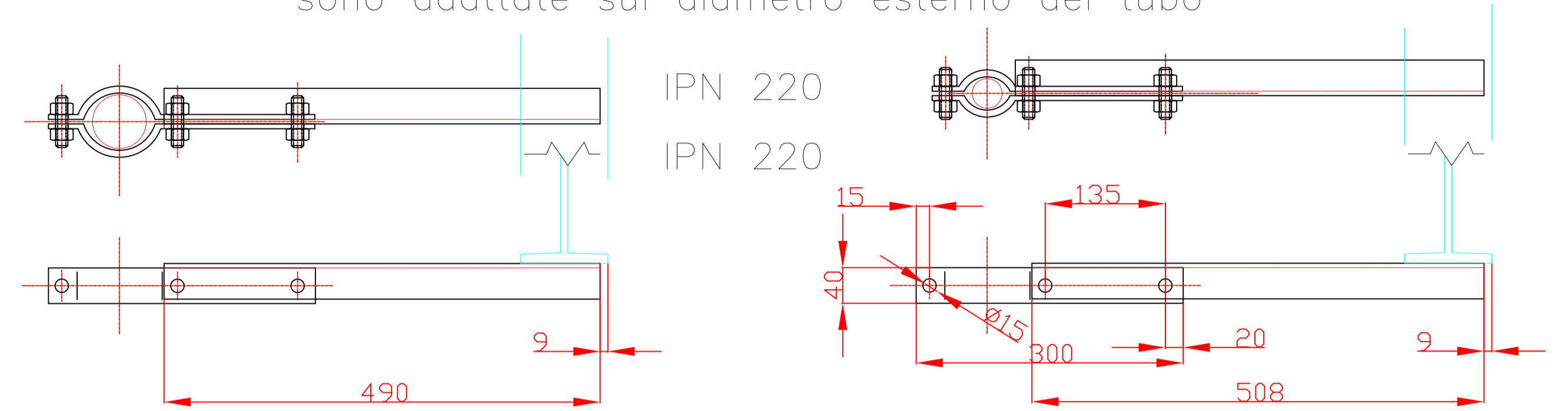

Molla a carico variabile tarata a 1000 N per supporto valvola EBT

taglio supporto valvola EBT
lini della molla sono i ad un profilato a T
tramite 1 vite M16

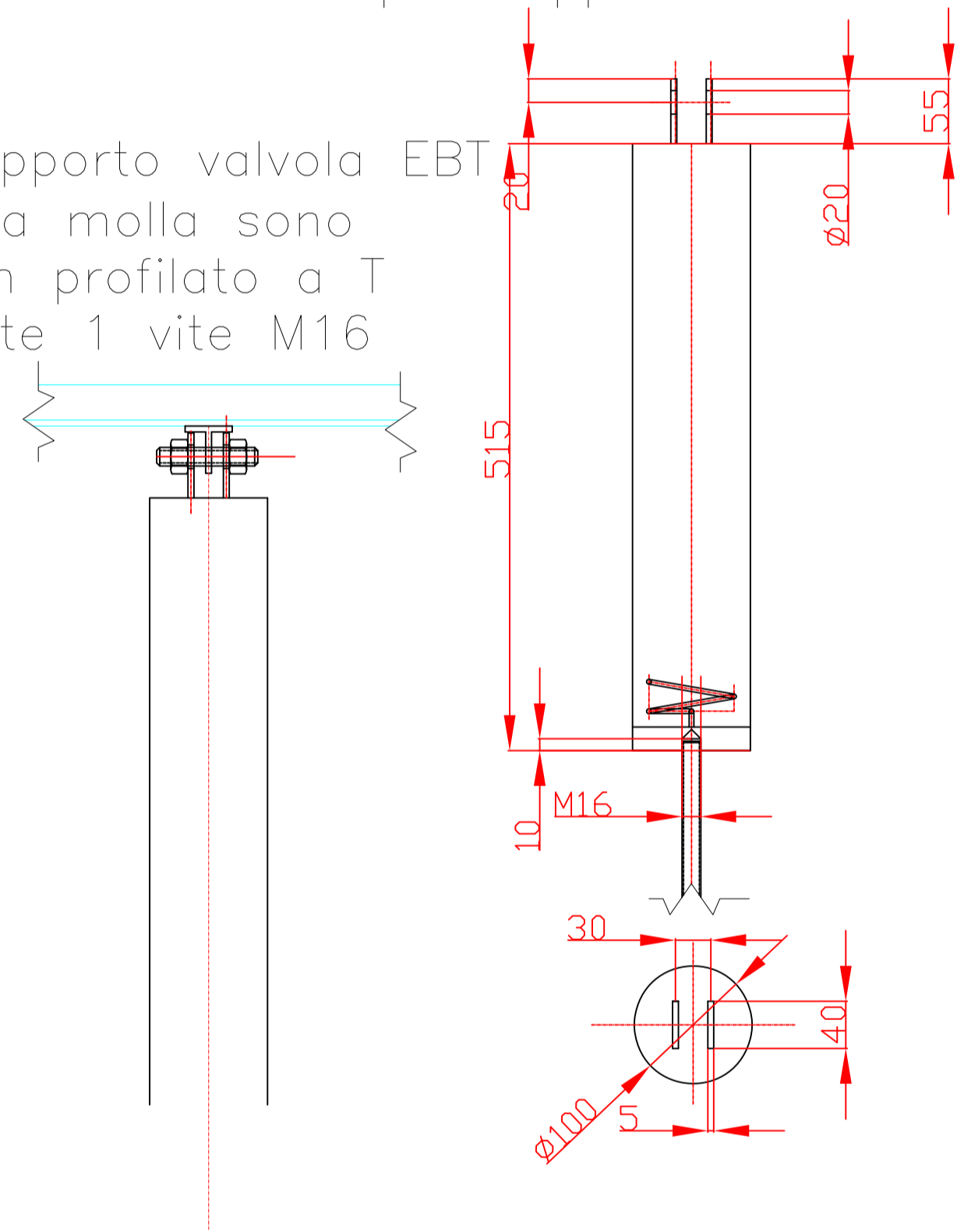

Dettaglio supporto per tee da 2" a tasca
staffe sagomate in piatto 35*5, bloccate con 2 viti M14, di cui una saldata a trave IPE 80, cui sono saldati, all'estremità, 2 tondi $\varnothing 35/18$, entro i quali passano i tiranti M16 che si collegano alla trave UPN 120. La distanza tra le piastre e la sagomatura sono adattate sul diametro esterno del tee.

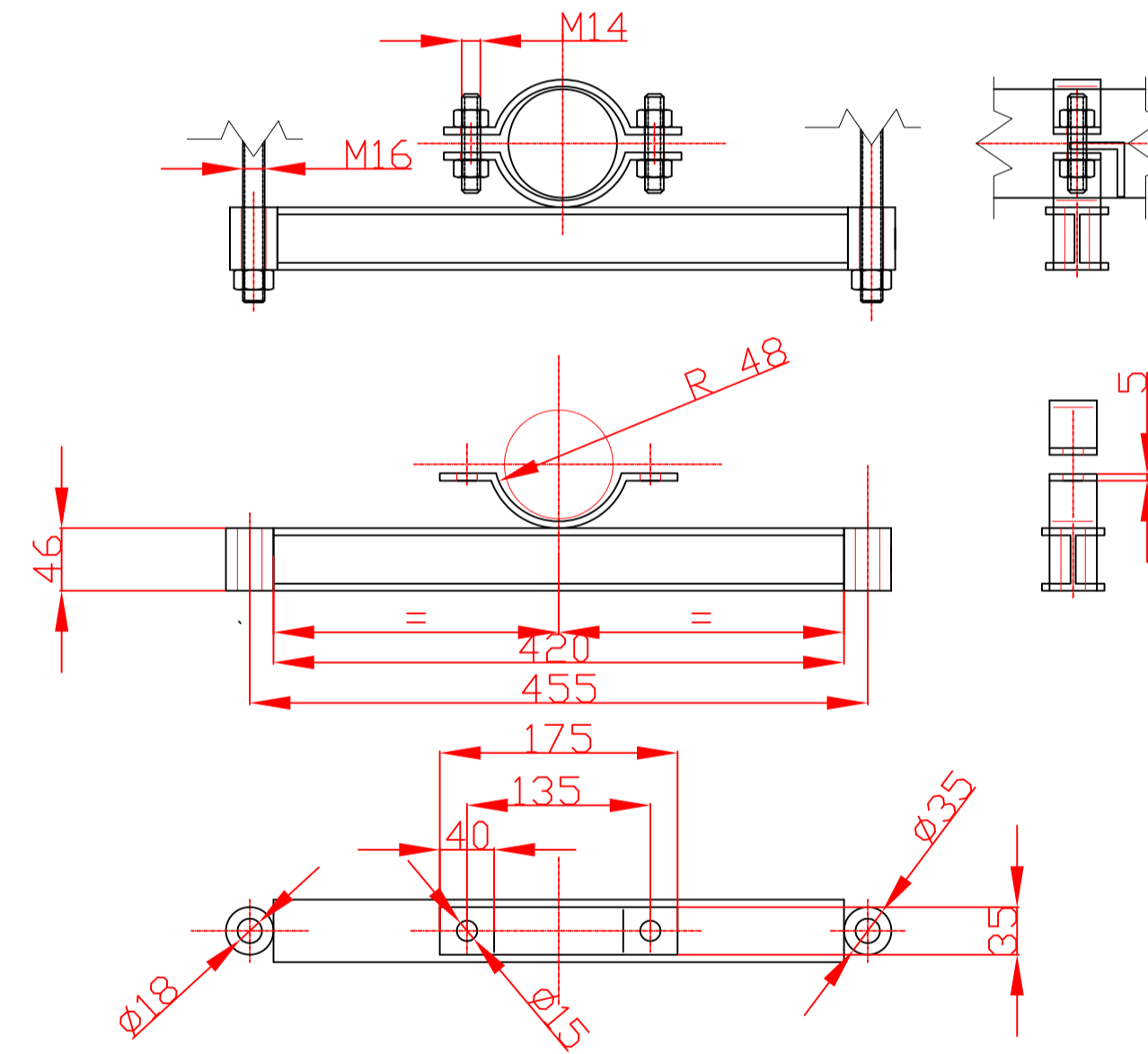

Dettaglio supporto per PRZ

staffe sagomate in piatto 50*5, bloccate con 6 viti M14 tra le 4 della parte più lunga è serrata un piatto 40x5, saldato a sbalzo sulla sommità della trave IPN 220. La distanza tra le piastre e la sagomatura sono adattate sul diametro esterno del tubo.

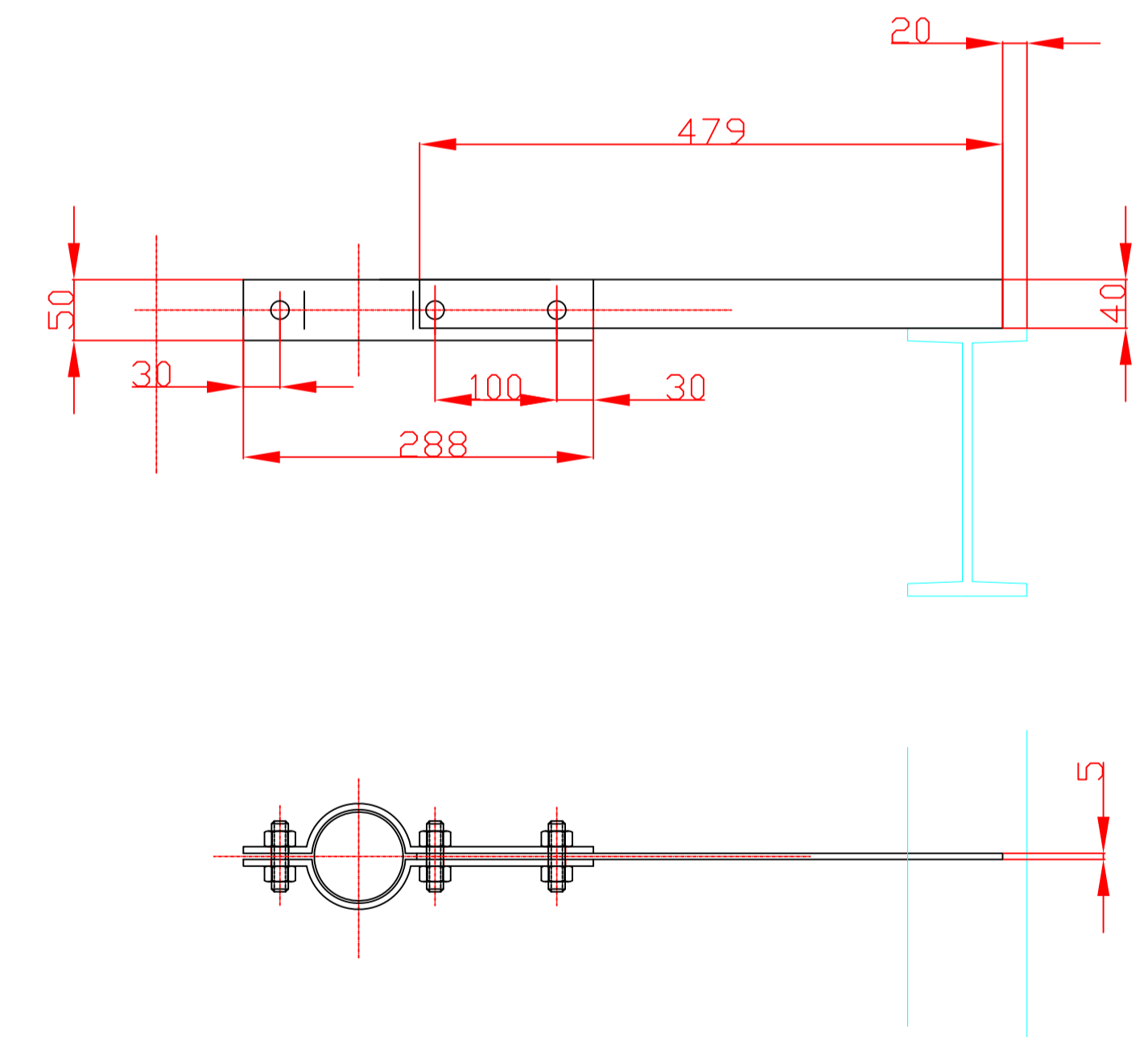

Dettaglio connessione impianto a struttura preesistente
piatto 70*130 sp.14, a cavallo delle ali di ciascuna trave IPN 220, con interposto blocchetto livellante 50*87 sp.12. Il tutto è bloccato con 2 bulloni M14 che collegano la trave IPN220 alla trave UPN 120. L'estremità inferiore della UPN 120 è collegata all'impianto tramite 3 coppie di tiranti M16.

blocchetto livellante

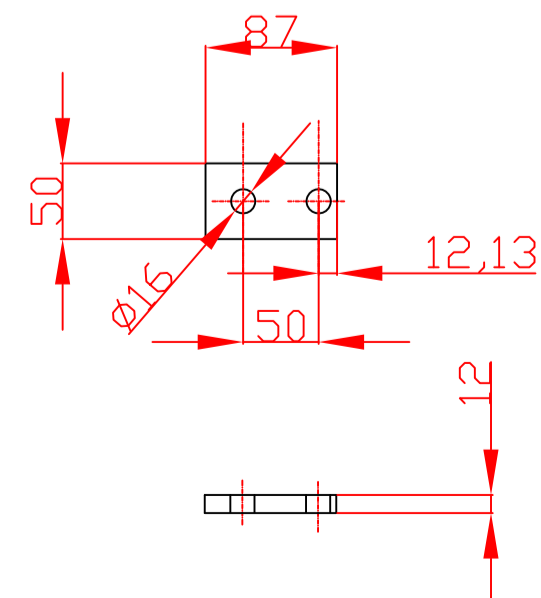

piatto 70*14

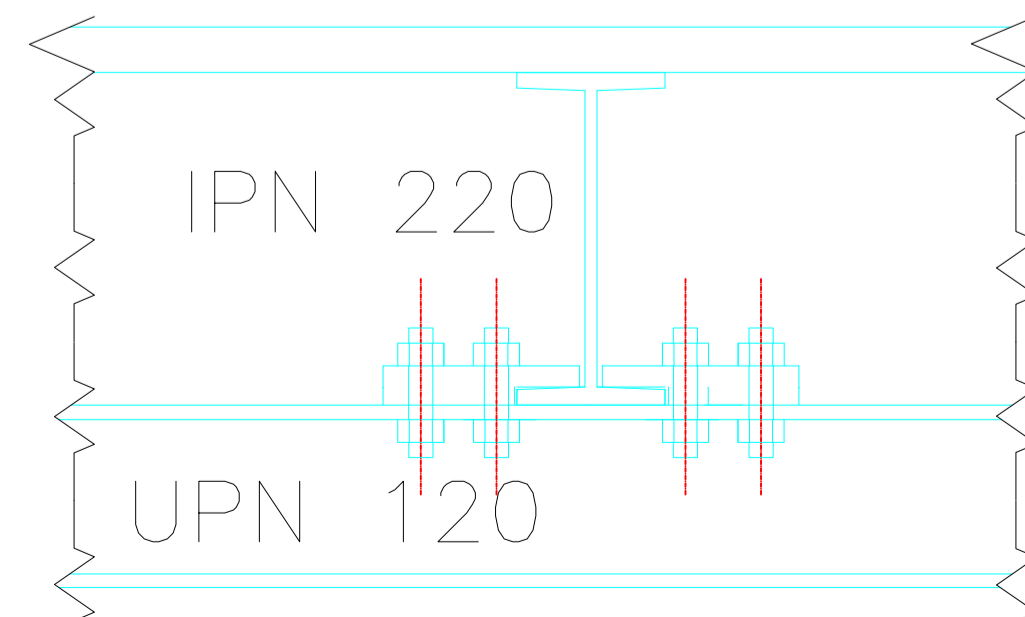
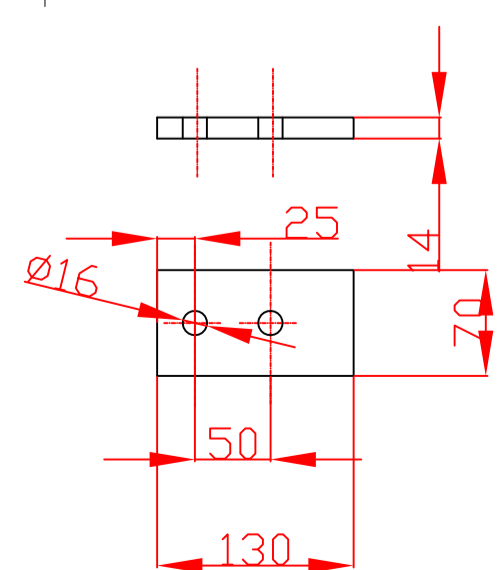

0	05/07/2010	As built	Congiu	A. Achilli
Rev.	Date	Modified	Dftm.	Controll. Approv.
OSIET		Impianto prova barre		
Piacenza - Italy		Posizionamento sulla struttura		
Scale		Dwg code	File	General code
1:5		074.00.02/4	074.00.02rev2.dwg	

074-01-00rev3:

Diagramma strumentato (2 fogli)

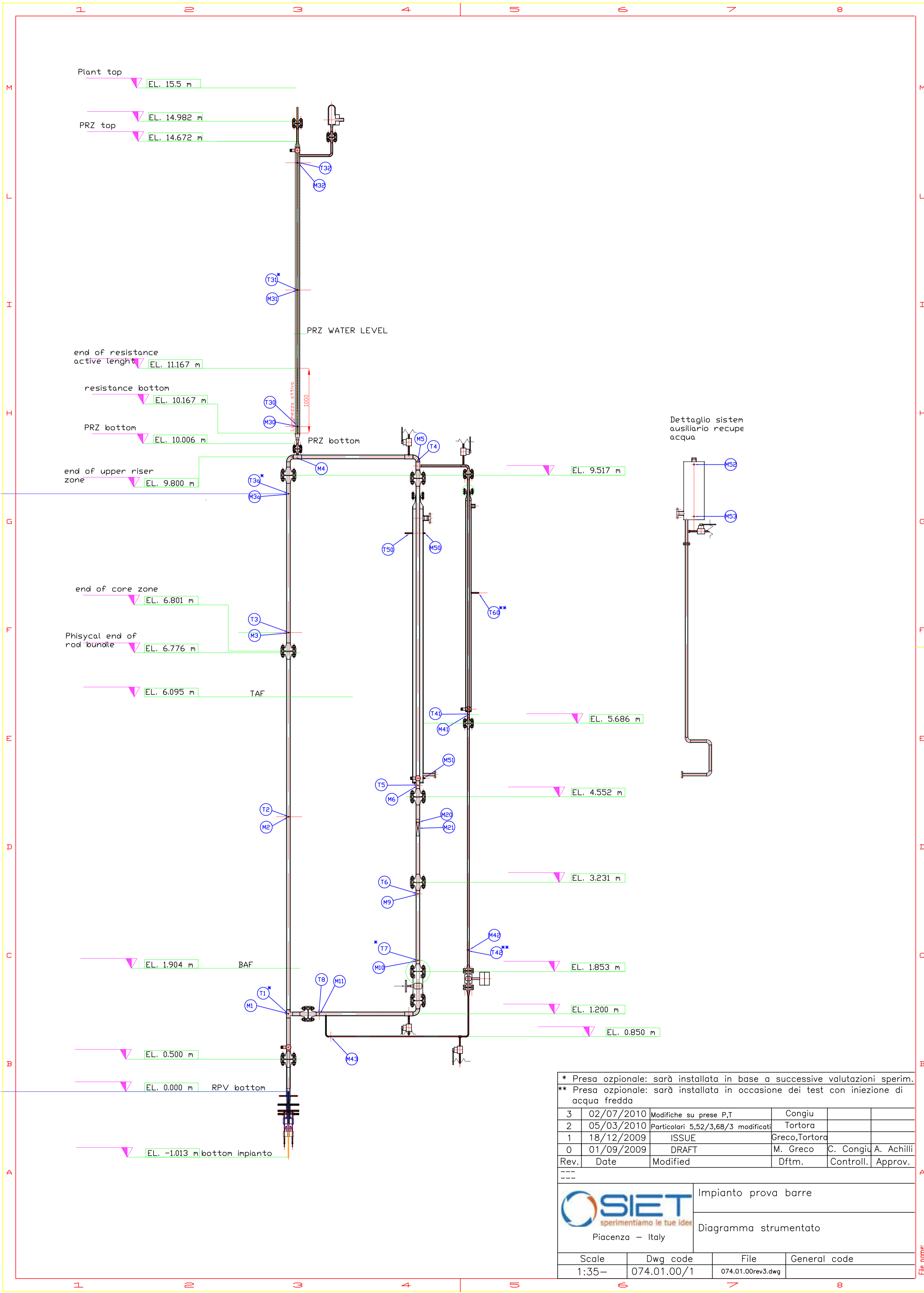

Dettaglio sistem
ausiliario recupe
acqua

* Presa opzionale: sarà installata in base a successive valutazioni sperim.
 ** Presa opzionale: sarà installata in occasione dei test con iniezione di acqua fredda

Rev.	Date	Modified	Dftm.	Controll.	Approv.
3	02/07/2010	Modifiche su prese P,T	Congiu		
2	05/03/2010	Particolari 5,52/3,68/3 modificati	Tortora		
1	18/12/2009	ISSUE	Greco, Tortora		
0	01/09/2009	DRAFT	M. Greco	C. Congiu	A. Achilli

		Impianto prova barre	
Piacenza - Italy		Diagramma strumentato	
Scale	Dwg code	File	General code
1:35-	074.01.00/1	074.01.00rev3.dwg	

File name:

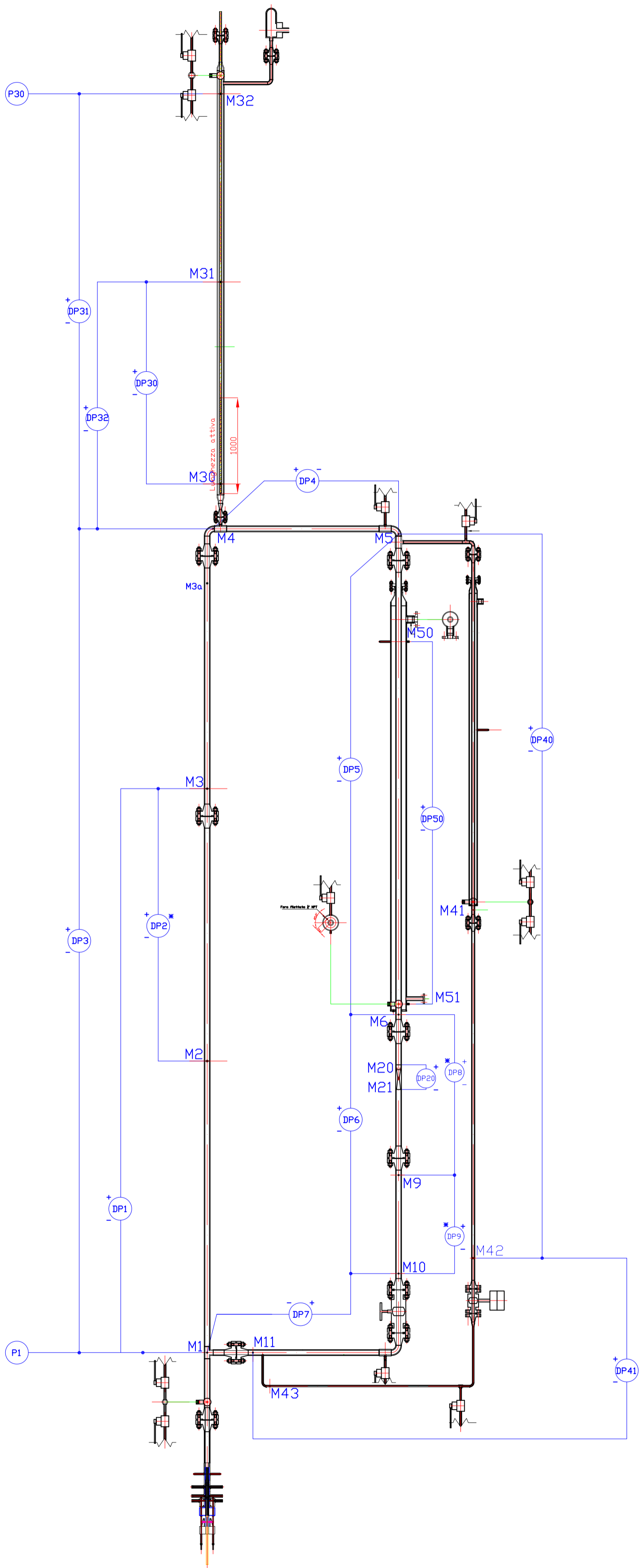

Dettaglio sistema ausiliario recupero acqua

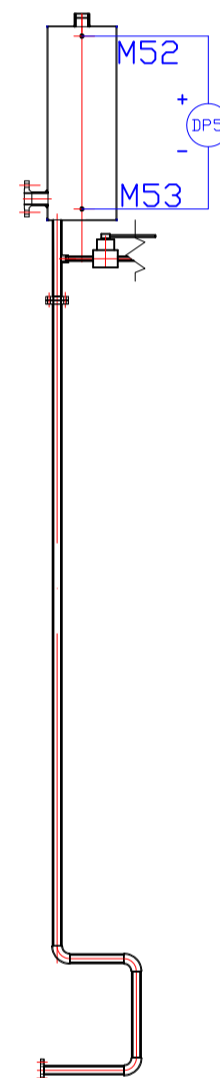

* Presa opzionale: sarà installata in base a successive valutazioni sperim.
 ** Presa opzionale: sarà installata in occasione dei test con iniezione di acqua fredda

3	02/07/2010	Modifiche su prese	Congiu		
2	05/03/2010	Particolari 5,52/3,68/3 modificati	Tortora		
1	18/12/2009	ISSUE	Greco, Tortora		
0	01/09/2009	DRAFT	M. Greco	C. Congiu	A. Achilli
Rev.	Date	Modified	Dftm.	Controll.	Approv.



Impianto prova barre
 Diagramma strumentato

Scale	Dwg code	File	General code
1:35-	074.01.00/2	074.01.00rev3.dwg	

File name:

074-02-00rev3:

Schema di flusso (P&ID)

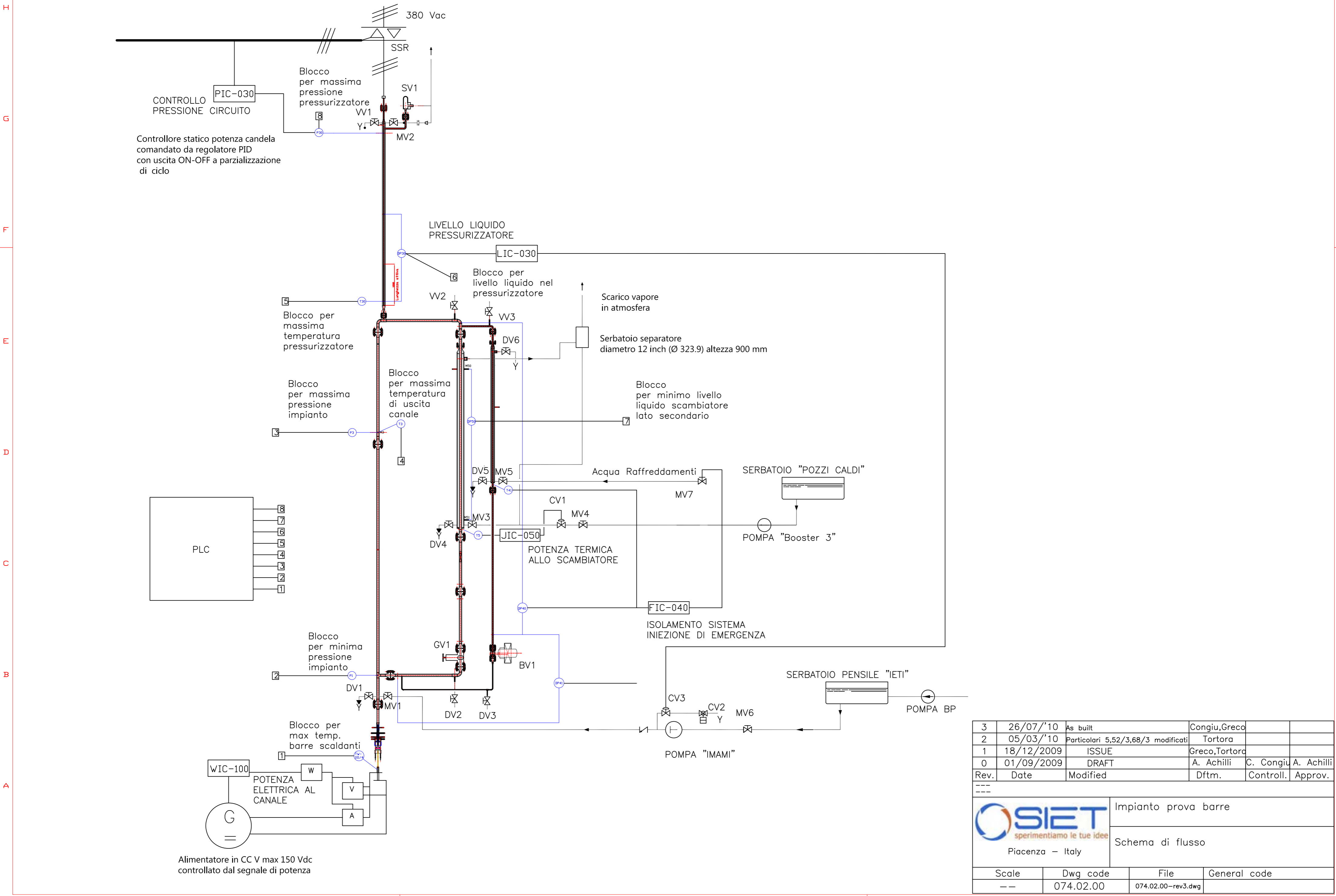

CONTROLLO PRESSIONE CIRCUITO
 PIC-030
 Controllore statico potenza candela comandato da regolatore PID con uscita ON-OFF a parzializzazione di ciclo

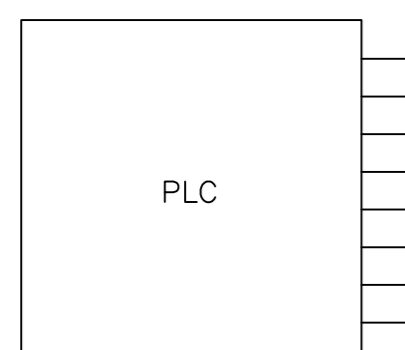

WIC-100
 POTENZA ELETTRICA AL CANALE
 Alimentatore in CC V max 150 Vdc controllato dal segnale di potenza

3	26/07/'10	As built	Congiu, Greco		
2	05/03/'10	Particolari 5,52/3,68/3 modificati	Tortora		
1	18/12/2009	ISSUE	Greco, Tortora		
0	01/09/2009	DRAFT	A. Achilli	C. Congiu	A. Achilli
Rev.	Date	Modified	Dftm.	Controll.	Approv.

SIET
 sperimentiamo le tue idee
 Piacenza - Italy

Impianto prova barre
 Schema di flusso

Scale	Dwg code	File	General code
--	074.02.00	074.02.00-rev3.dwg	